

■ Package Dimension:

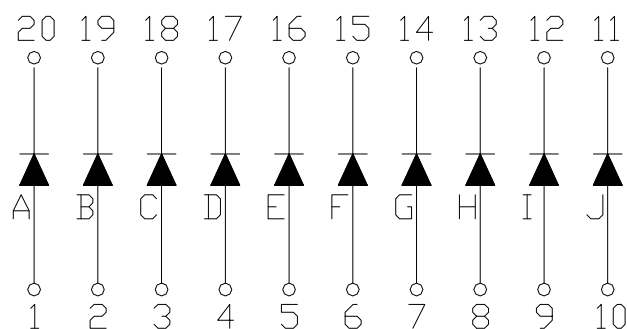
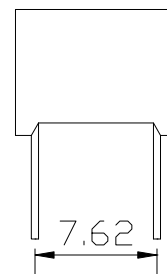
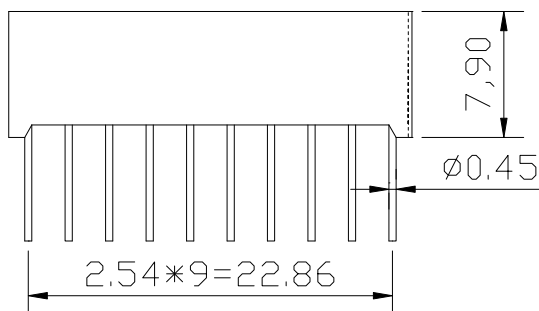
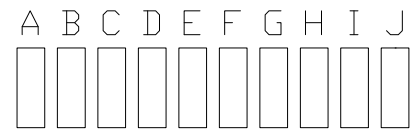
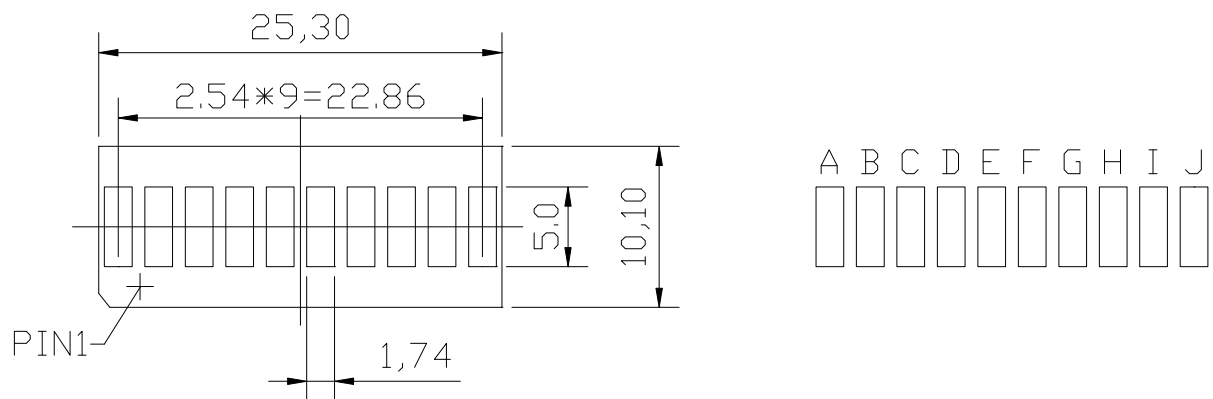

Notes:

1. All dimensions are in millimeter.
2. An epoxy meniscus may extend about 0.25mm(0.1") down to the lead
3. Tolerances unless Dimension ± 0.25 mm.

LED Parts P/N.	Chip		Lens Color
	Material	Emitted Color	
ALB-1000I	GaAsP	Hi-Effi Red	- - -

■ Absolute Maximum Ratings at Ta=25°C

Parameter	Symbol	Rating	Unit
Continuous Forward Current	I_F	50	mA
Operating Temperature	T_{opr}	-40~+80	°C
Storage Temperature	T_{stg}	-40~+80	°C
Soldering Temperature	T_{sol}	260±5	°C
Power Dissipation	P_D	100	mW
Peak Forward Current (Duty 1/10@1KHz)	I_F (Peak)	100	mA
Reverse Voltage	V_R	5	V

■ Electronic Optical Characteristics :

Parameter	Symbol	Min.	Typ.	Max.	Unit	Condition
Luminous Intensity	I_V	8	15	20	mcd	$I_F=20mA$
Peak Wavelength	λ_p	639	644	649	nm	$I_F=20mA$
Dominant Wavelength	λ_d	625	630	635	nm	$I_F=20mA$
Spectrum Radiation Bandwidth	$\Delta \lambda$	37	42	47	nm	$I_F=20mA$
Forward Voltage	V_F	1.6	2.0	2.5	V	$I_F=20mA$
Reverse Current	I_R	/	/	100	μA	$V_R=5V$

■ Reliability test items and conditions :

The reliability of products shall be satisfied with items listed below.

Confidence level: 90%

LTPD: 10%

NO	ITEM	Test Conditions	Test hours/cycle	Sample Q'ty	Ac/Re
1	Solder Heat	Temp : 260°C±5°C	5 sec	80 pcs	0/1
2	Temperature Cycle	H : +85°C 30min ∧ 5min L : -40°C 30min	100 cycles	80 pcs	0/1
3	Thermal Shock	H : +100°C 5min ∧ 10sec L : -10°C 5min	100 cycles	80 pcs	0/1
4	High Temperature Storage	Ta=100°C	1000 hrs	80 pcs	0/1
5	Low Temperature Storage	Ta=-40°C	1000 hrs	80 pcs	0/1
6	DC Operating Life	Temp : 25°C I _F =20mA	1000 hrs	80 pcs	0/1
7	High Temperature / High Humidity	85°C / 85%RH	1000 hrs	80 pcs	0/1

■ Typical electro-optical characteristics curves :

The data typical, and the value is not guaranteed.

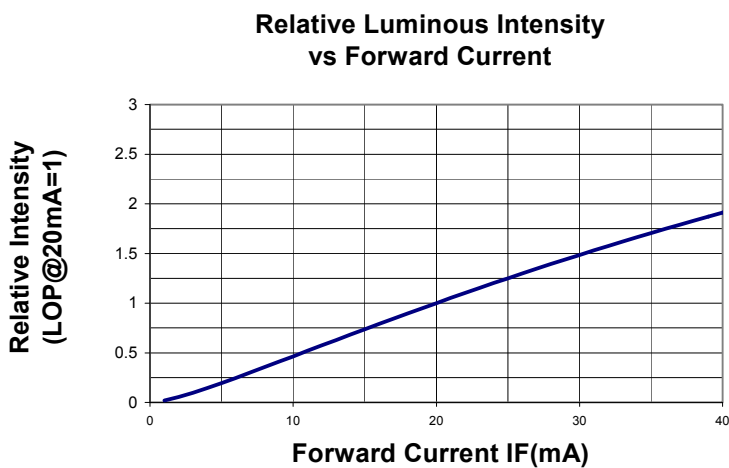
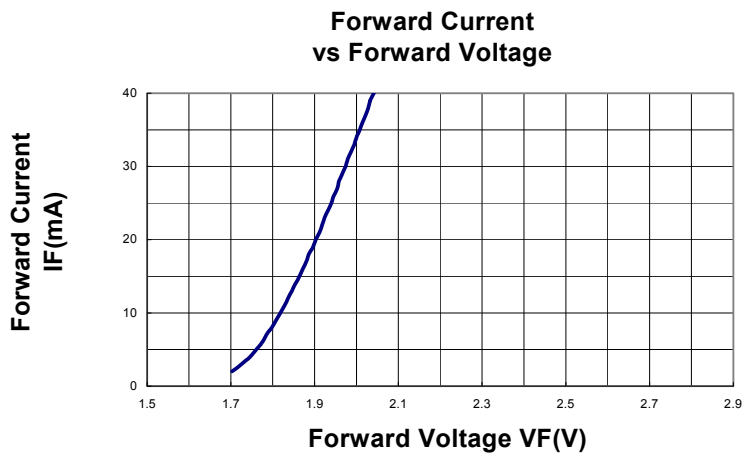
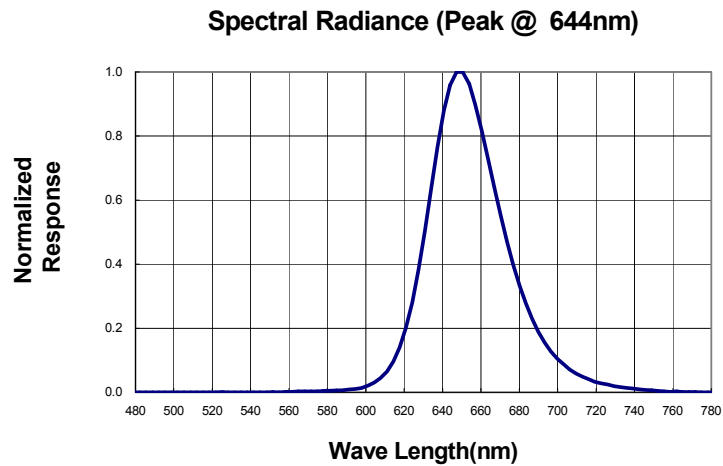

Distributed by:
Electus Distribution Pty Ltd
46 Eastern Creek Dr,
Eastern Creek NSW 2766 Australia
1300 738 555 | electusdistribution.com.au

Made in China