

Part No.

AL-B513ID-004

Diff No. 004

5 mm

Round

Type : Blinking Lamps

Package Dimension :

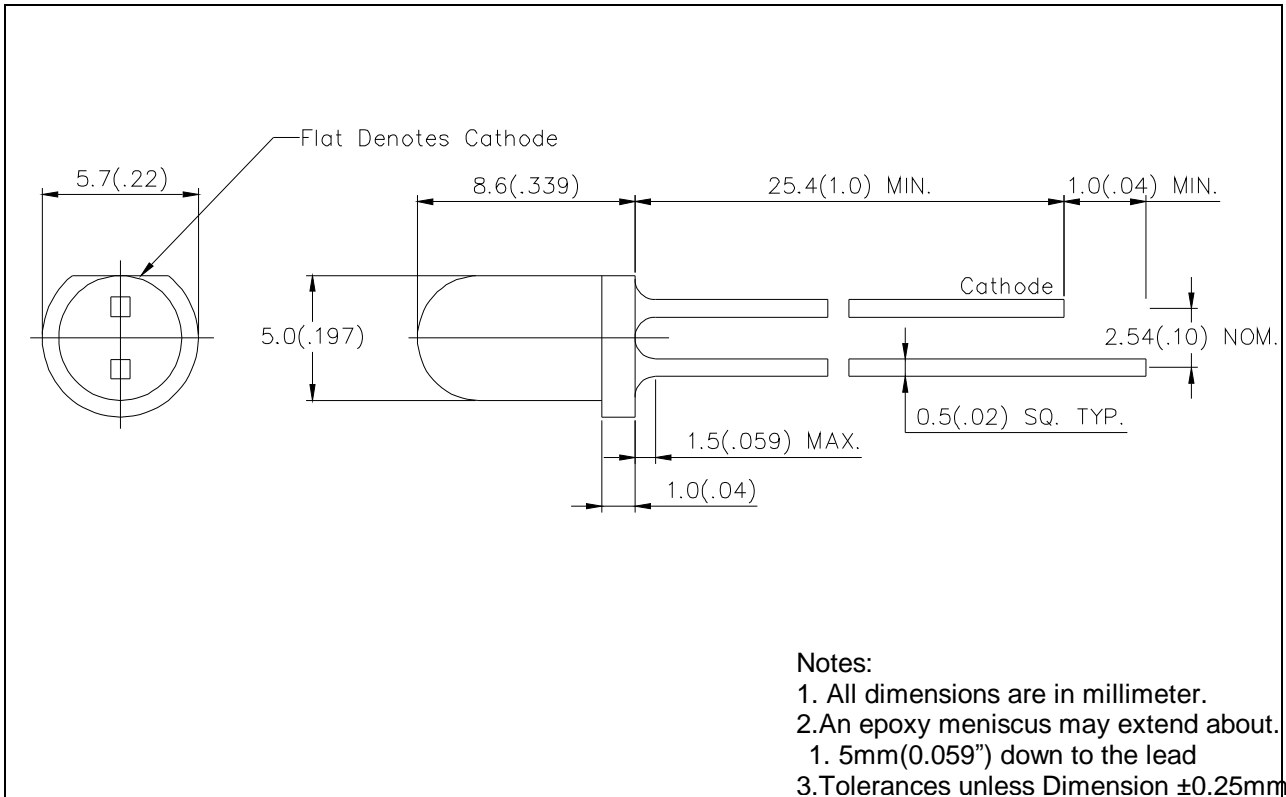

n Features :

l Choice of various viewing angles

l Available on Tape and Reel.

l Reliable and robust.

n Descriptions :

l The series is specially designed for application requiring higher brightness.

l The LED lamps are available with different colors, intensity, epoxy colors etc.

n Applications :

l TV set

l Monitor

l Telephone

Part No. AL-B513ID-004

Diff No. 004

5 mm

Round

Type : Blinking Lamps

PART NO.	Chip		Lens Color
	Material	Emitted Color	
AL-B513ID-004	GaAsP/GaP	Hi-Effi Red	Red Diffused

■ Absolute Maximum Ratings at Ta=25°C

Parameter	Symbol	Rating	Unit
Forward Current	I _F	25	mA
Operating Temperature	T _{opr}	0 to +70	°C
Storage Temperature	T _{stg}	-20 to +85	°C
Soldering Temperature	T _{sol}	260±5	°C
Operating Voltage (Max.)	---	12	V
Storage Voltage (Max.)	---	0.5	V
Electrostatic Discharge	ESD	1000	V
Reverse Voltage	V _R	5	V

■ Electronic Optical Characteristics :

Parameter	Symbol	Min.	Typ.	Max.	Unit	Condition
Luminous Intensity	I _v	/	50	/	mcd	I _F =10mA
Pulse Rate	---	2.0	2.4	2.8	Hz	V _{DD} =5V
Viewing Angle	2θ _{1/2}	/	50	/	deg	I _F =20mA
Peak Wavelength	λ _p	/	635	/	nm	I _F =20mA
Dominant Wavelength	λ _d	/	630	/	nm	I _F =20mA
Spectrum Radiation Bandwidth	Δλ	/	45	/	nm	I _F =20mA

Part No. AL-B513ID-004

Diff No. 004

5 mm

Round

Type : Blinking Lamps

■ Reliability test items and conditions :

Classification	Test Item	Reference Standard	Test Conditions	Result
Endurance Test	Operation Life	MIL-STD-750:1026 MIL-STD-883:1005 JIS C 7021 :B-1	Connect with a power V=10V Ta=Under room temperature Test time=1,000hrs	0/20
	High Temperature High Humidity Storage	MIL-STD-202:103B JIS C 7021 :B-11	Ta=+65°C±5°C RH=90%-95% Test time=1,000hrs	0/20
	High Temperature Storage	MIL-STD-883:1008 JIS C 7021 :B-10	High Ta=+85°C±5°C Test time=1,000hrs	0/20
	Low Temperature Storage	JIS-C-7021 :B-12	Low Ta=-35°C±5°C Test time=1,000hrs	0/20
Environmental Test	Temperature Cycling	MIL-STD-202:107D MIL-STD-750:1051 MIL-STD-883:1010 JIS C 7021 :A-4	-35°C ~ +25°C ~ +85°C ~ +25°C 60min 20min 60min 20min Test Time=5cycle	0/20
	Thermal Shock	MIL-STD-202:107D MIL-STD-750:1051 MIL-STD-883:1011	+85°C±5°C ~ -35°C±5°C 20min 20min Test Time=10cycle	0/20
	Solder Resistance	MIL-STD-202:201A MIL-STD-750:2031 JIS C 7021 :A-1	Preheating : 140°C-160°C, within 2 minutes. Operation heating : 235°C (Max.), within 10 seconds. (Max.)	0/20

Part No.

AL-B513ID-004

Diff No. 004

5 mm

Round

Type : Blinking Lamps

■ Typical Characteristics (The data typical, and the value is not guaranteed.)

