

XC9046 USB Joystick Interface

The XC9046 USB Joystick Interface allows the creation of custom joystick hardware with a common USB interface. On the USB end, the device appears as a generic game device, and has been tested to work with no configuration on Lakka on Raspberry Pi. It should work fine with any operating system that supports USB game devices. The following instructions show how it can be connected to your joysticks and button. The configuration of the joystick may need to be changed by changing which button is connected to which input, or by manually configuring the game to suit the connections.

The general layout of the connections is:

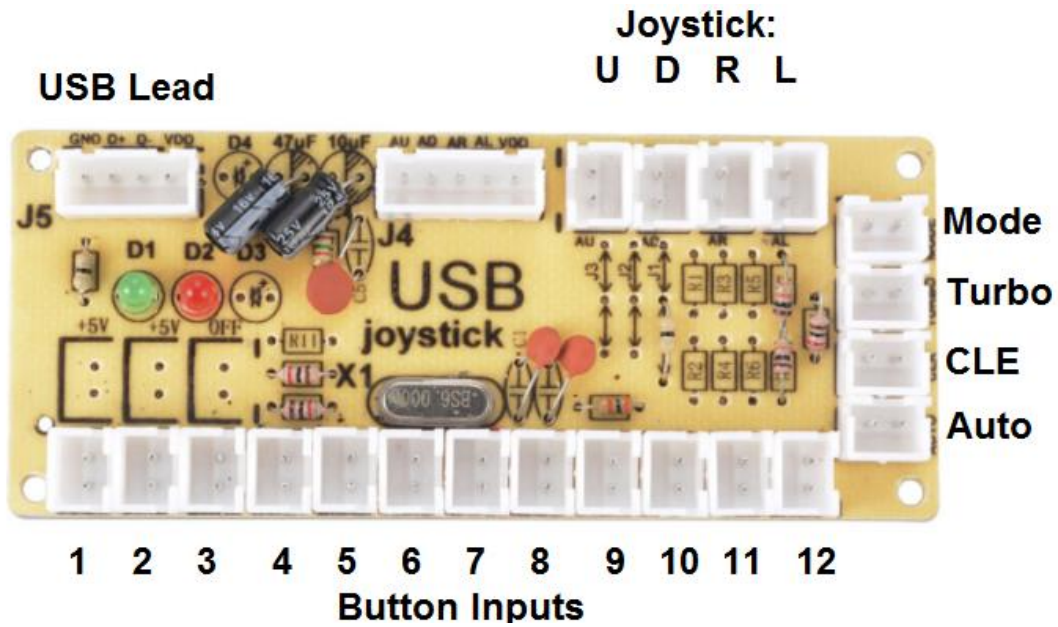

The input is activated when the two pins of an input are connected together. For buttons like SP0662, SP0664, SP0665, SP0666 and SP0669 and joysticks with microswitches like SM0152, this means the wires are connected to the COM and NO connections (the spades should push straight onto the microswitch), and the white plug connects to the USB Interface Board. For simple devices like switches, polarity is not important (ie it doesn't matter if the blue and white leads are reversed on the pushbutton). For devices that are polarity sensitive, the white wire connects to ground, so should be the most negative connection if the switch is polarised.

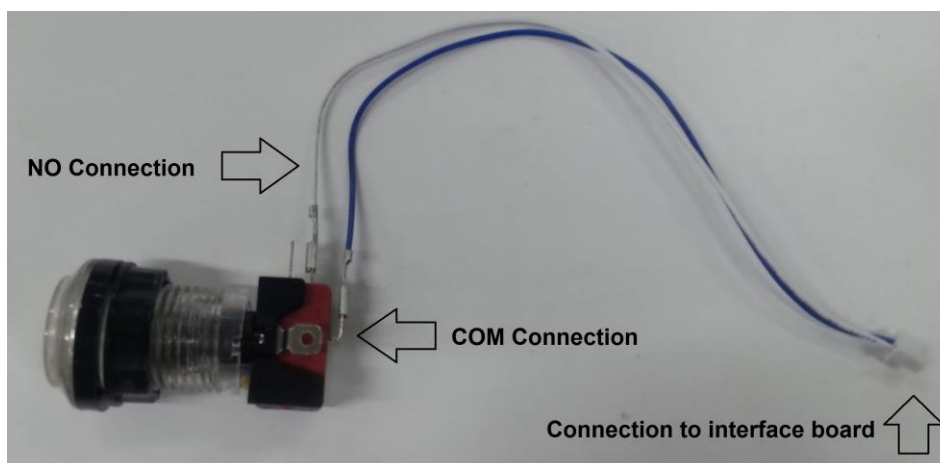

In the case of the SM1052, there are only two spade terminals, so just use these.

The spades can be difficult to remove once attached, so it can be easier to reconfigure by unplugging the white plug from the interface board and shifting it.

The five-pin header next to the joystick connector is connected to the joystick connector, and can be used if the joystick has a corresponding five-pin plug.