

Distributed by:  
Electus Distribution Pty. Ltd.  
320 Victoria Rd, Rydalmere  
NSW 2116 Australia

Ph: 1300 738 555  
Int'l: +61 2 8832 3200  
Fax: 1300 738 500

[www.electusdistribution.com.au](http://www.electusdistribution.com.au)

Made in China

# duinotech

## micro:bit Starter Kit V3 XC4328 User Manual

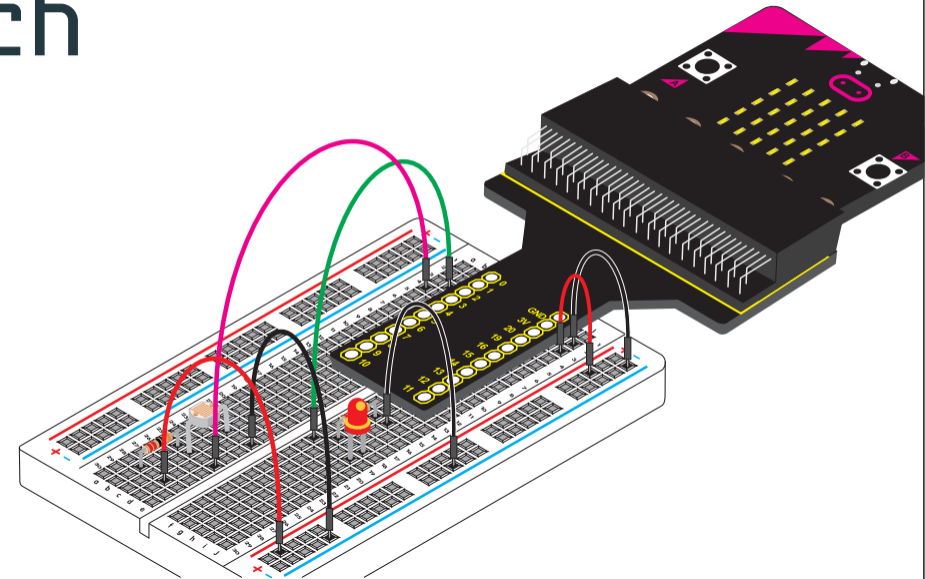

## Component List

1 T-type Breakout Board Adapter *1	2 USB Cable *1	3 2-cell Battery Holder *1	4 Jumper Wire *1	
5 400-hole Breadboard *1	6 9G Servo Motor *1	7 1-digit LED Display *1	8 Passive Buzzer *1	9 Active Buzzer *1
10 Tactile Button Button Cap *2	11 103 Potentiometer *1	12 F5-RGB LED *1	13 18b20 Temp. Sensor *1	14 5MM Photocell *3
15 Thermistor *1	16 IR Receiver Flame *1	17 Ball Tilt Switch *2	18 F5-Red LED *5	19 F5-Yellow LED *5
20 F5-Blue LED *5	21 F5-Green LED *5	22 220R Resistor *10	23 1K Resistor *10	24 10K Resistor *10

# Displaying Hello World

Project  
1

## Description:

First, let's start a pretty simple experiment that make your micro bit main board display "Hello World!" only using a micro bit main board and a USB cable. This is an entry level for you to test the communication between micro bit and PC. Here we will use a serial communication software (Arduino IDE), hope that we will lead you to a wonderful micro bit world.

## Testing Result:

Connect the micro:bit board to computer, powered up, open Arduino IDE, set the COM port as below figure shown, then upload the testing code.

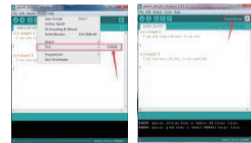

Finally, open serial monitor, select the baud rate 115200 (because the baud rate of micro:bit serial communication is 115200), enter an "R", then click "Send", you can see the monitor display "Hello world!".

## Hardware Required:

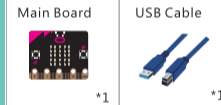

## Get Code:

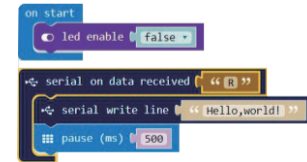

## About:

### About micro:bit:

The BBC micro:bit is a powerful handheld, fully programmable, computer designed by BBC. It is designed to make learning and teaching easy and fun. You can encourage children to get actively involved in writing software and building new things that will be controlled by your BBC micro:bit for all sorts of cool creations, from robots to musical instruments – the possibilities are endless.

Meet BBC micro:bit website here: <http://microbit.org/>

### About the kit:

If you are just getting started into the world of electronics and coding or want that ideal gift for a young maker, this kit is the perfect choice. No soldering or prior programming knowledge required. At the heart of the kit is the micro:bit board which is a powerful handheld, fully programmable, computer designed by the BBC. It has an accelerometer to detect movement and tilting, a magnetic sensor to detect metal or create a compass, and up to 23 inputs to connect to the physical world. The board also has a 5 x 5 LED display and two onboard input push buttons provide instant control. The kit includes common electronics components from resistors to a servo motor, and all the necessary prototyping accessories to get building. A 36-page beginners guide is also included to get you started.

Full instructions and any required code can be downloaded from the GitHub resource site here: <https://github.com/Jaycar-Electronics/micro-bit-Starter-Kit>







# Blinking an LED

Project  
**2**

## Description:

LED blinking is one of the basic experiments. In micro:bit using method, you can see the 5\*5 LED dot matrix is enabled. Here we are going to finish LED blinking experiment using an external plug LED, so at first you have to close the led enable function.

## Hardware Required:

Main Board  *1	Breadboard  *1	T-type Adapter  *1
220Ω Resistor  *1	LED  *1	USB Cable  *1
Jumper Wire  *2		

## Get Code:

```
on start
  led enable false

forever
  digital write pin P9 to 1
  pause (ms) 500
  digital write pin P9 to 0
  pause (ms) 500
```

## Circuit Diagram:

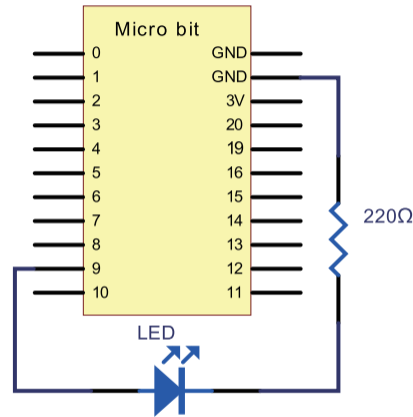

## Testing Result:

Powered up, done uploading the code to board, you can see the external LED light connected on IO port is blinking, with an interval about 0.5 second.

## Connection Diagram:

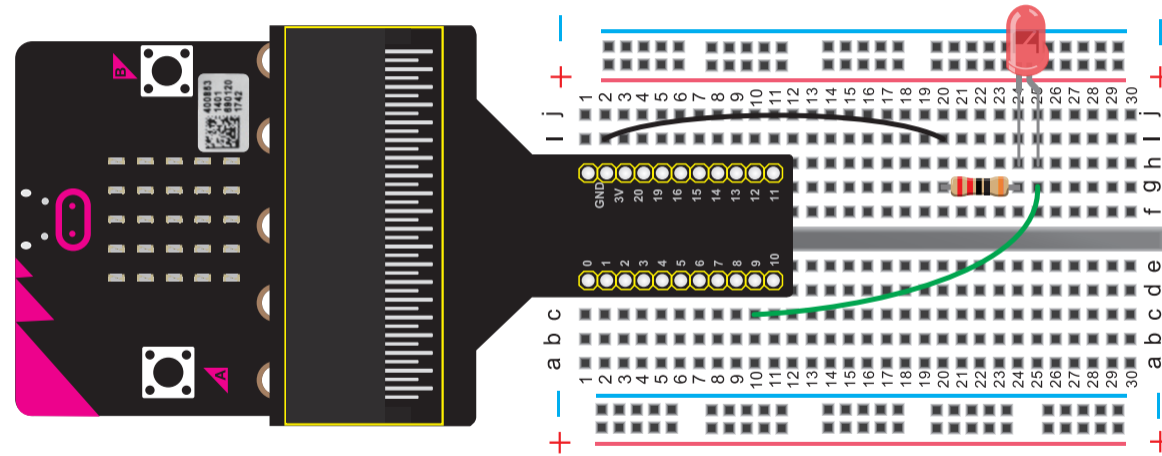

# Simulating Advertising Light

## Project 3

### Description:

In daily life, you may often see some advertising boards composed of various LED lights. Different LED lights on the advertising board can form an amazing lighting effect. In this lesson, we will use LED light program to simulate the advertising light, brightening and dimming one by one.

### Hardware Required:

Main Board *1	Breadboard *1	T-type Adapter *1
220Ω Resistor *5	LED *5	USB Cable *1
Jumper Wire *7		

### Get Code:

```
on start
  led enable false
  forever
    digital write pin P5 to 1
    pause (ms) 500
    digital write pin P6 to 1
    pause (ms) 500
    digital write pin P7 to 1
    pause (ms) 500
    digital write pin P8 to 1
    pause (ms) 500
    digital write pin P9 to 1
    pause (ms) 500
    digital write pin P10 to 1
    pause (ms) 500
```

### Circuit Diagram:

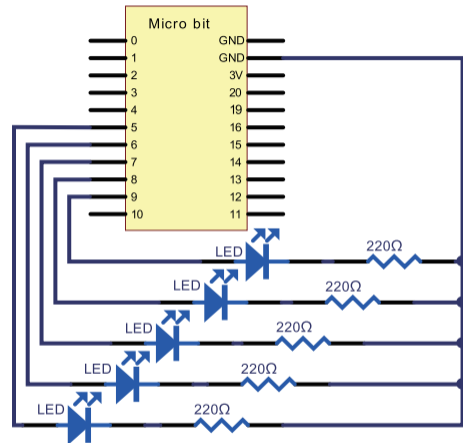

### Testing Result:

Powered up and done uploading the code, you can see the external LED lights connected on IO port are brightening, and then dimming one by one circularly.

### Connection Diagram:

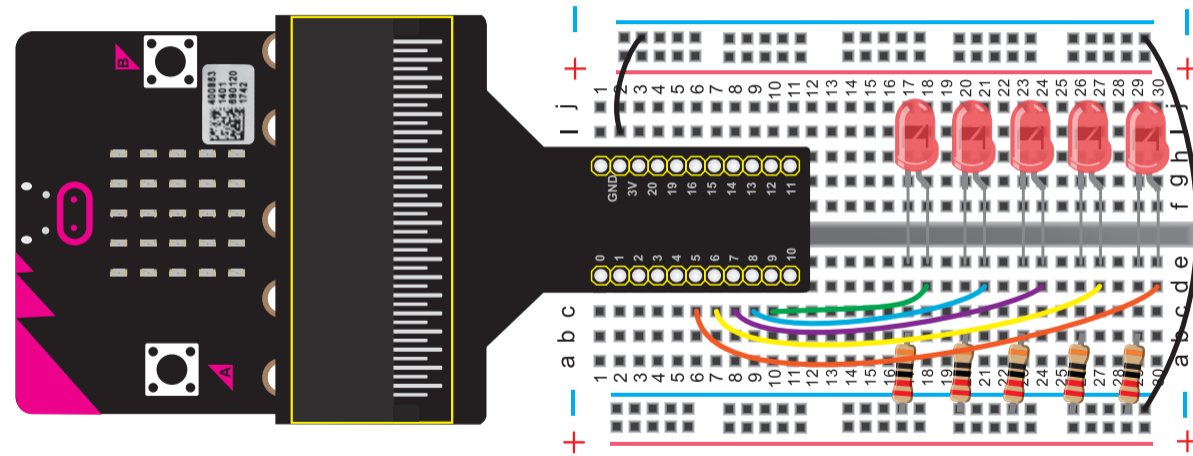









# Button-controlled LED

Project  
**4**

## Description:

Micro:bit has three built-in buttons, two for user buttons (labelled A and B), one for reset button. This time, we are going to use a user button on the micro:bit to control external LED on and off.

## Hardware Required:

Main Board  *1	Breadboard  *1	T-type Adapter  *1
220Ω Resistor  *1	LED  *1	USB Cable  *1
Jumper Wire  *2		

## Get Code:

```
on start
  led enable false

forever
  if button A is pressed
    then digital write pin P6 to 1
  else digital write pin P6 to 0
```

## Circuit Diagram:

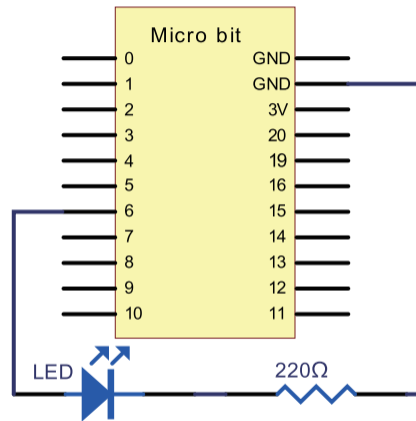

## Testing Result:

Powered up, done uploading the code to board, when pressing down the button A on the micro:bit, LED on; if not, LED off.

## Connection Diagram:

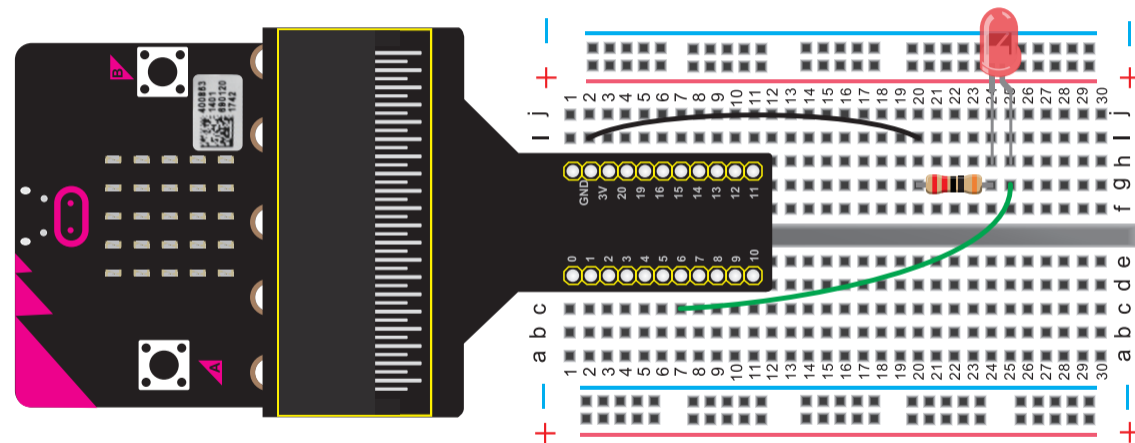









# Making a Responder

Project  
**5**

## Description:

We have use micro:bit built-in button to control LED light in the previous experiment. This time, we will use it to make a responder, really interesting. Using a built-in button on micro:bit as reset button, connecting two tactile buttons as responder button to control two external LEDs.

## Hardware Required:

Main Board  *1	Breadboard  *1	T-type Adapter  *1
220Ω Resistor  *2	10KΩ Resistor  *2	Tactile Button  *2
LED  *2	USB Cable  *1	Jumper Wire  *9

## Circuit Diagram:

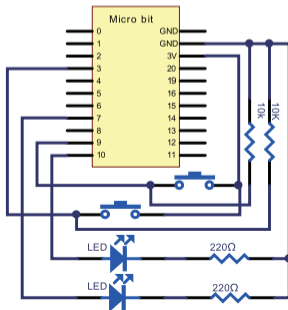

## Get Code:

```
on start
  led enable false

forever
  if digital read pin P5 = 0
    then
      digital write pin P10 to 0
      digital write pin P7 to 0
  if digital read pin P9 = 1
    then
      while digital read pin P5 = 1
        do
          digital write pin P10 to 1
          digital write pin P7 to 0
  if digital read pin P3 = 1
    then
      while digital read pin P5 = 1
        do
          digital write pin P10 to 0
          digital write pin P7 to 1
```

## Testing Result:

Powered up and done uploading the code, a simple responder is finished. You can judge who answer first successfully according to the displayed color of LED. Press down the button A on micro:bit used as reset button, two LED lights off.

## Connection Diagram:

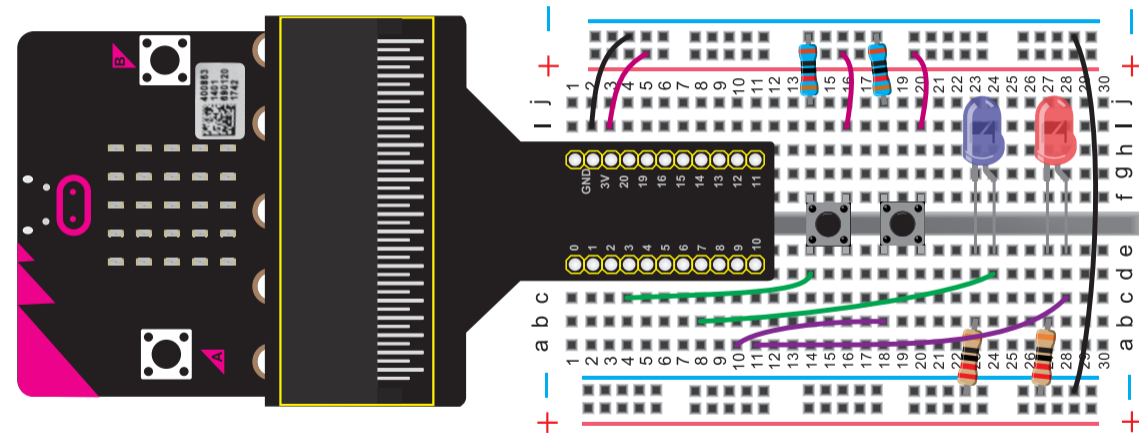







# Breathing an LED

Project  
**6**

## Description:

You may have mastered LED on and off controlling based on the above projects, so this time learn to control LED brightness in the code. We are going to control LED on and off gradually, just like breathing simulation. So need to control 25 programmable LEDs on micro:bit and external LED to achieve breathing light effect. Note that external LED must be connected to analog port.

## Hardware Required:

Main Board  *1	Breadboard  *1	T-type Adapter  *1
220Ω Resistor  *1	LED  *1	USB Cable  *1
Jumper Wire  *2		

## Circuit Diagram:

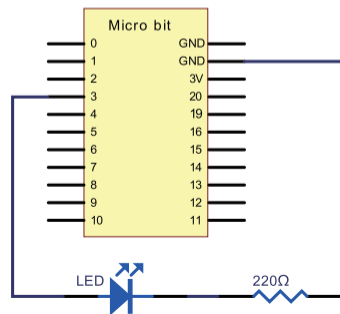

## Get Code:

### 5\*5 LED matrix:

```
on start
  led enable true
  forever
    while brightness < 255
      do
        set brightness to brightness + 1
        plot x 2 y 3 brightness brightness
        pause (ms) 5
    while brightness > 0
      do
        set brightness to brightness - 1
        plot x 2 y 3 brightness brightness
        pause (ms) 5
```

### External LED:

```
on start
  led enable false
  forever
    while brightness < 1023
      do
        set brightness to brightness + 1
        analog write pin P3 to brightness
        wait (μs) 900
    while brightness > 0
      do
        set brightness to brightness - 1
        analog write pin P3 to brightness
        wait (μs) 900
```

## Testing Result:

Powered up, done uploading the code, LED is gradually dimming, and then brightening alternatively, looking like breathing.

## Connection Diagram:

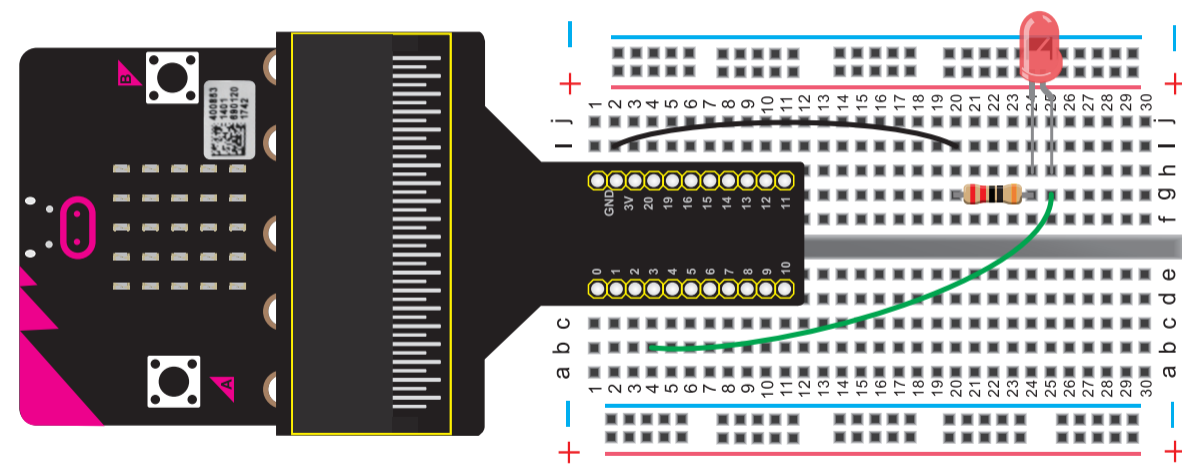









# Controlling LED Brightness

Project  
**7**

## Description:

In previous lesson, we have directly control the LED brightness in the code. In this lesson, you will learn how to use a potentiometer to control the brightness of an LED. Note that external LED and potentiometer must be connected to analog port.

## Hardware Required:

Main Board  *1	Breadboard  *1	T-type Adapter  *1
220Ω Resistor  *1	LED  *1	Potentiometer  *1
USB Cable  *1	Jumper Wire  *7	

## Get Code:

```
on start
  led enable false
  forever
    set brightness to (analog read pin P4)
    analog write pin P3 to brightness
  pause (ms) 100
```

## Circuit Diagram:

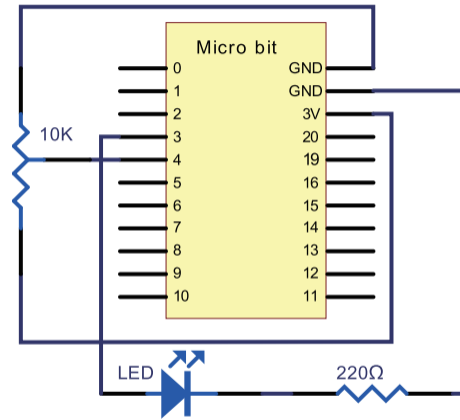

## Testing Result:

Done wiring and uploading the code, you can adjust the brightness of LED by rotating the knob on the potentiometer.

## Connection Diagram:

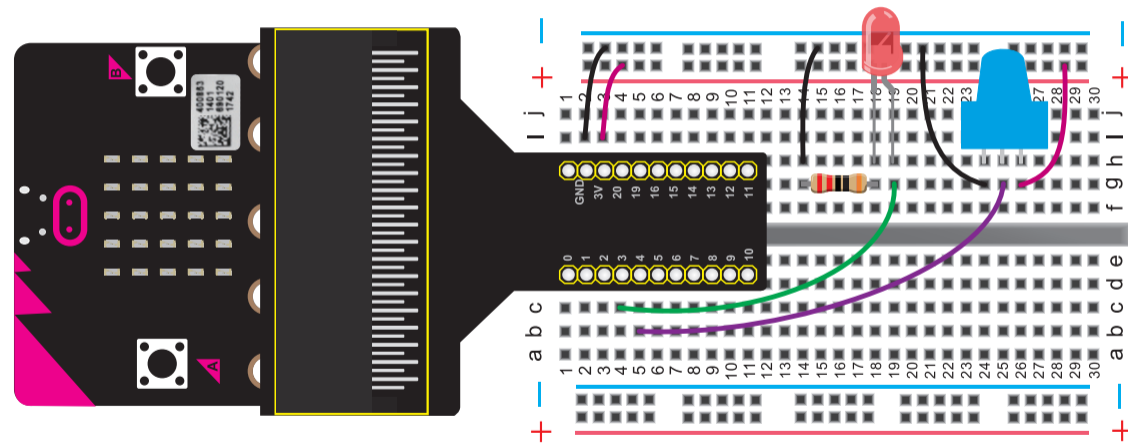







# RGB LED

## Project 8

### Description:

RGB color model is an additive color model in which red, green and blue light are added together in various way to reproduce a broad array colors. The name of the model RGB comes from the initials of the three additive primary colors, red, green, and blue. In this lesson, we will use a RGB light to achieve full-color mixing effect, through controlling the voltage input of R/G/B pins to adjust the intensity of three primary colors (red/green/blue).

### Hardware Required:

Main Board  *1	Breadboard  *1	T-type Adapter  *1
RGB LED  *1	USB Cable  *1	Jumper Wire  *4

### Circuit Diagram:

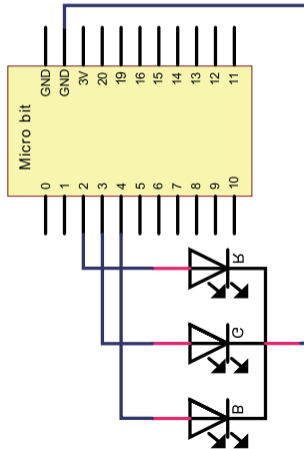

### Get Code:

```
on start
  led enable false
  forever
    analog write pin P2 to 1023
    pause (ms) 500
    analog write pin P2 to 0
    analog write pin P3 to 1023
    pause (ms) 500
    analog write pin P3 to 0
    analog write pin P4 to 1023
    pause (ms) 500
    analog write pin P4 to 0
    analog write pin P2 to 1023
    analog write pin P3 to 1023
    pause (ms) 500
    analog write pin P4 to 0
    analog write pin P2 to 1023
    analog write pin P3 to 1023
    pause (ms) 500
```

### Testing Result:

Done wiring and powered up, downloading the code to micro: bit, you can see the RGB LED will continue to emit red light for 1S, green light for 1S, blue light for 1S, yellow light for 1S, purple light for 1S, white light for 1S, circularly.

### Connection Diagram:

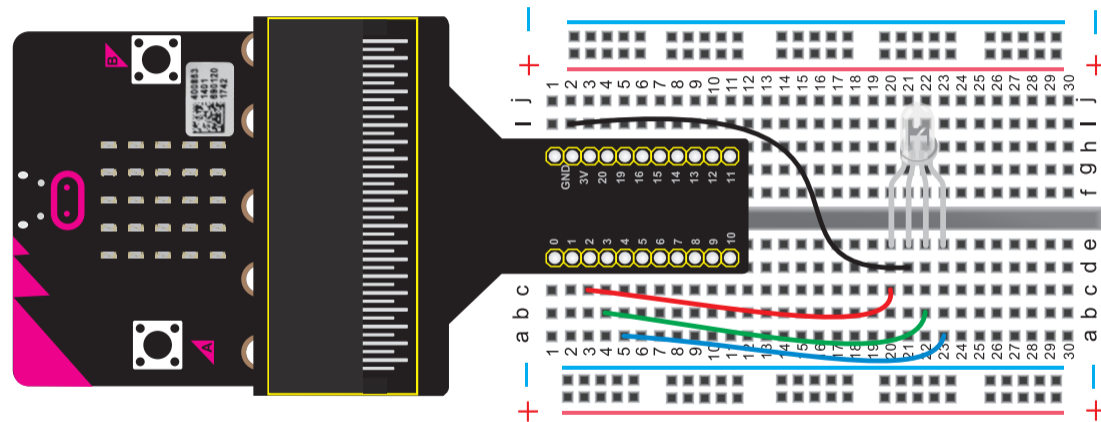









# Photosensitive Light

Project  
**9**

## Description:

This lesson, let's start a rather simple photocell experiment. Photocell is a component that can change its resistance according to the light intensity. In this experiment, you can learn from the LED brightness controlled by potentiometer, just replace the potentiometer with photocell to achieve the effect that the brightness of LED will be changed once light intensity is different.

## Hardware Required:

Main Board  *1	Breadboard  *1	T-type Adapter  *1
220Ω Resistor  *1	10KΩ Resistor  *1	5MM Photocell  *1
LED  *1	USB Cable  *1	Jumper Wire  *7

## Get Code:

```
on start
  led enable false

forever
  set brightness to (analog read pin P4)
  analog write pin P3 to brightness
  pause (ms) 100
```

## Circuit Diagram:

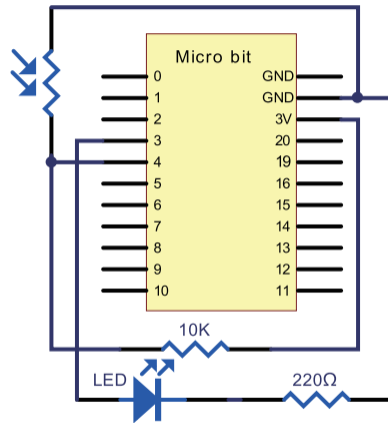

## Testing Result:

Done downloading the code into micro:bit, you can see that the brighter the photocell senses, the darker the LED; the darker the photocell senses, the brighter the LED.

## Connection Diagram:

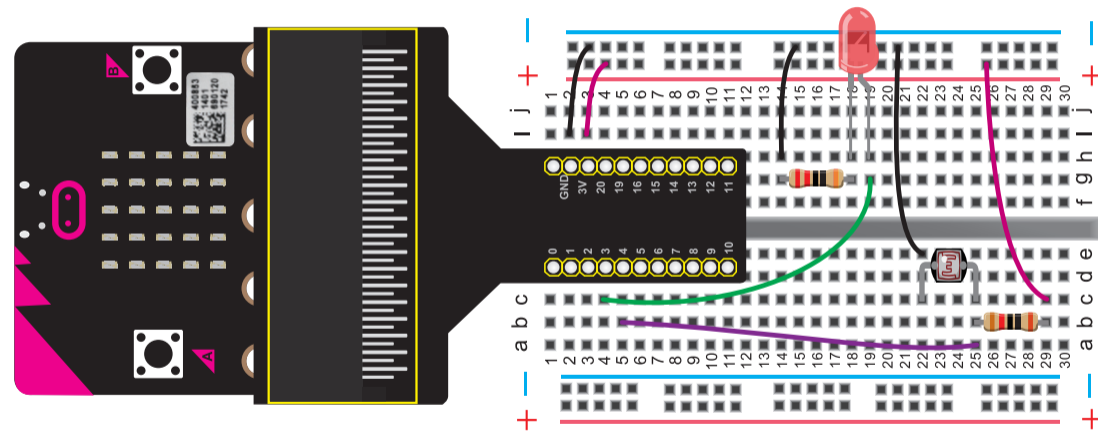







# Active Buzzer

Project  
10

## Description:

There are two kinds of buzzer, active buzzer and passive buzzer. In this lesson, we will use micro:bit to drive an active buzzer. The active buzzer inside has a simple oscillator circuit which can convert constant direct current into a certain frequency pulse signal. Once active buzzer receives a high level, it will produce an audible beep.

## Hardware Required:

Main Board  *1	Breadboard  *1	T-type Adapter  *1
Active Buzzer  *1	USB Cable  *1	Jumper Wire  *2

## Get Code:

```
on start
  led enable false
  forever
    digital write pin P0 to 1
    pause (ms) 500
    digital write pin P0 to 0
    pause (ms) 500
```

## Circuit Diagram:

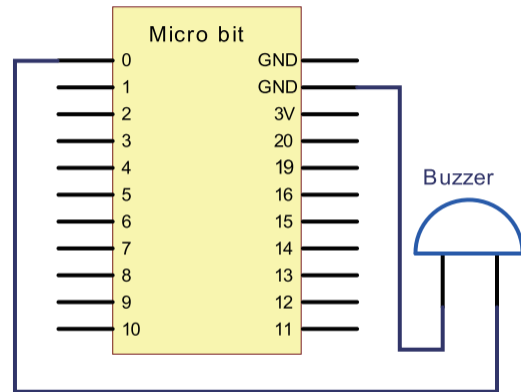

## Testing Result:

Finally, you can hear the active buzzer beep for 0.5 second, then stop and beep for 0.5 second circularly.

## Connection Diagram:

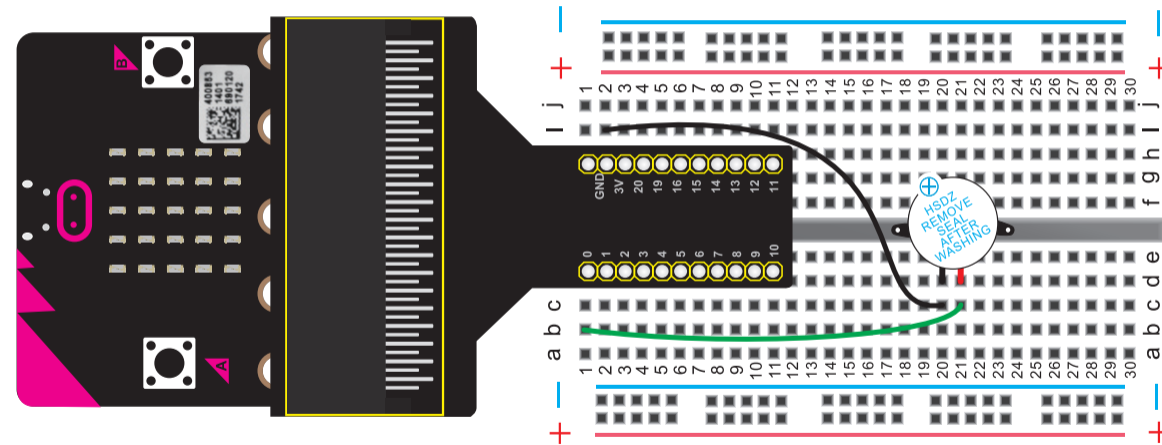





# Driving Servo Motor





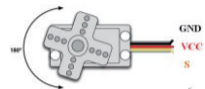

Project  
12

## Description:

Servo motor is a position control rotary actuator. It mainly consists of housing, circuit board, core-less motor, gear and position sensor. Servomotor comes with many specifications. But all of them have three connection wires, distinguished by brown, red and orange (different brand may have different color). Brown one is for GND, red one for power positive, orange one for signal line.



## Hardware Required:

Main Board  *1	Breadboard  *1	T-type Adapter  *1
9G Servo Motor  *1	Potentiometer  *1	USB Cable  *1
Jumper Wire  *8		

## Get Code:

```
on start
  led enable false

forever
  set servo to
  map
    from low 0
    from high 1023
    to low 0
    to high 180
  servo write pin P3 to servo
```

## Circuit Diagram:

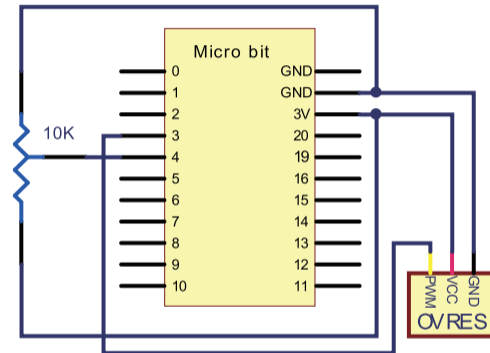

## Testing Result:

Done wiring and downloading the code into micro:bit, you can rotate the knob on the top of potentiometer to adjust the turning angle of servo motor.

## Connection Diagram:

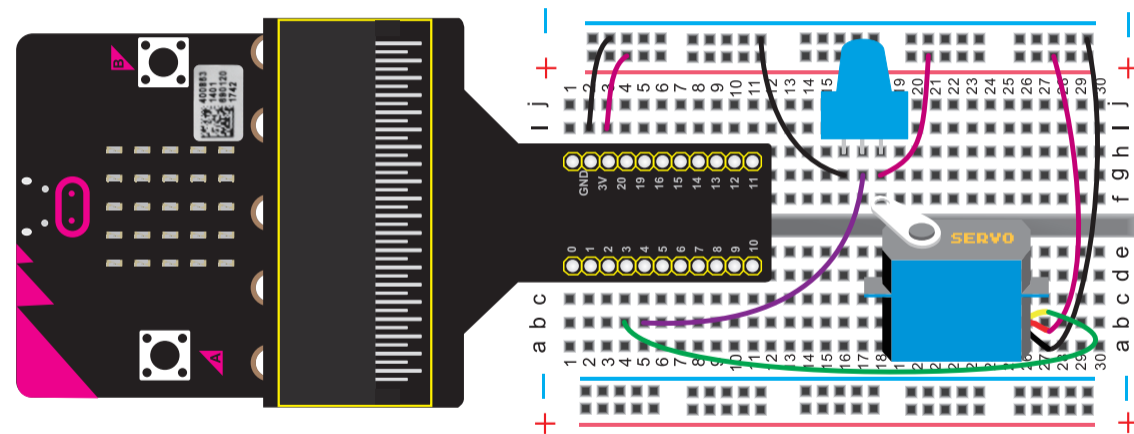









# Flame Alarm

Project  
13

## Description:

Flame sensor (Infrared receiving triode) is specially used on robots to find the fire source. This sensor is of high sensitivity to flame. Flame sensor is made based on the principle that infrared ray is highly sensitive to flame. It has an infrared receiving tube to detect fire, and then converts the flame brightness into fluctuating level signal. In this experiment, we are going to control the buzzer sound through inputting the fluctuating level signal into micro:bit board.

## Hardware Required:

Main Board  *1	Breadboard  *1	T-type Adapter  *1
10KΩ Resistor  *1	Flame Sensor  *1	Active Buzzer  *1
USB Cable  *1	Jumper Wire  *7	

## Get Code:

```
on start
  led enable false
forever
  if digital read pin P3 = 1
  then digital write pin P0 to 1
  else digital write pin P0 to 0
```

## Circuit Diagram:

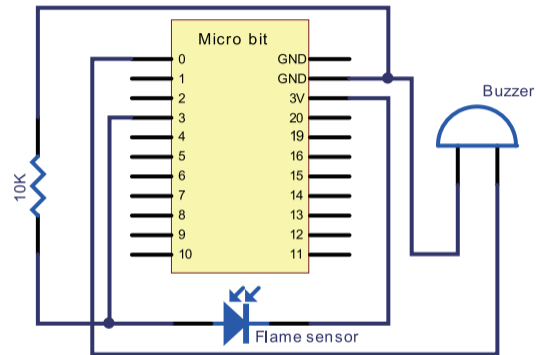

## Testing Result:

If flame sensor detects the flame nearby, the active buzzer beeps; or else, it will not sound.

## Connection Diagram:

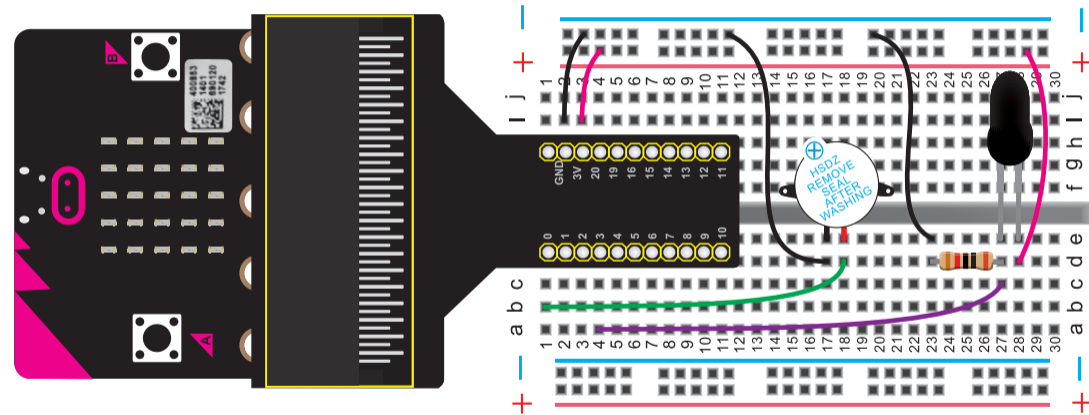











# Magical Light Cup

Project  
15

## Description:

When one end of tilt switch is lower than the horizontal position, it performs a turn-on operation; while another end is lower than the horizontal position, tilt switch turns off. The experiment adopts the principle of using analog value to regulate light brightness. So the brightness of two LEDs in the experiment will make a change. The ball tilt switch provides digital signal to trigger analog value regulation, after programming, you can see the magical light effect of these two LEDs.

## Hardware Required:

Main Board  *1	Breadboard  *1	T-type Adapter  *1
10KΩ Resistor  *2	LED  *2	Ball Tilt Switch  *2
USB Cable  *1	Jumper Wire  *11	

## Circuit Diagram:

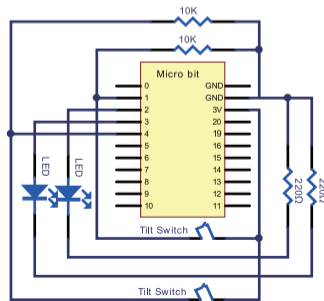

## Get Code:



## Testing Result:

Wiring and downloading the code into micro:bit, tilt the two switches to common one side at the same time, you can see that one LED dims gradually, while another one becomes brighter gradually. Finally, one LED off, while the other becomes the brightest.

## Connection Diagram:

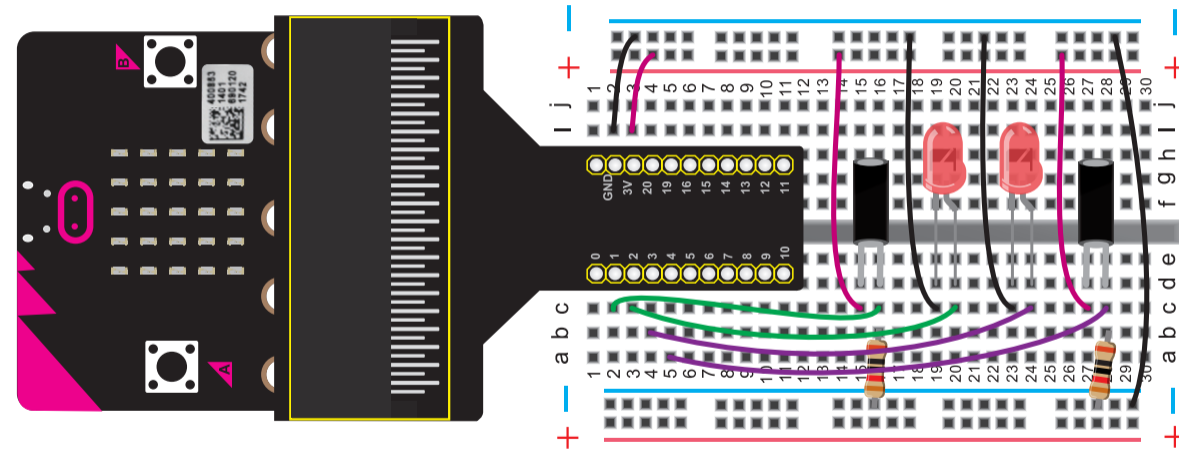

# Micro:bit Analog Read

Project  
16

## Description:

In this experiment, we will use a potentiometer to adjust the analog quantity of P2 (refer to the below pin guide). When rotating the potentiometer, analog quantity makes a change and is displayed on the serial monitor. Note that it needs to use a serial communication software, Arduino IDE.

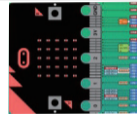

## Hardware Required:

Main Board *1	Breadboard *1	T-type Adapter *1
Potentiometer *1	USB Cable *1	Jumper Wire *2

## Get Code:

```
on start
  led enable false
  forever
    serial write number analog read pin P2
    serial write line ""
  pause (ms) 200
```

## Circuit Diagram:

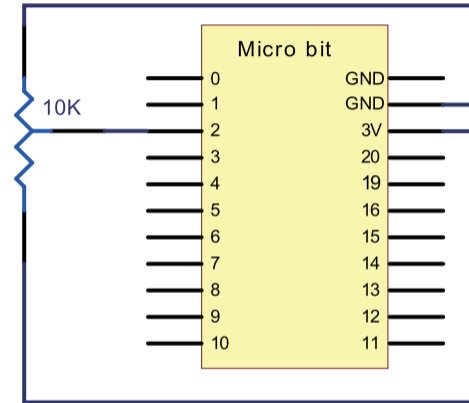

## Testing Result:

Done wiring, open Arduino IDE, set the COM port, and download the code into micro:bit board. Then, open serial monitor, set the baud rate as 115200 (because micro:bit serial communication baud rate is 115200).

## Connection Diagram:

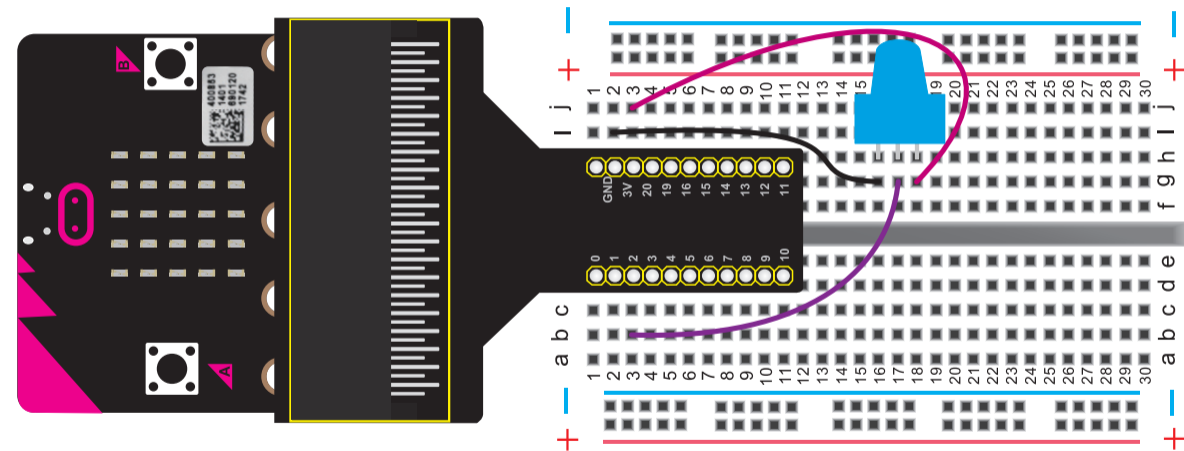







# Thermistor Sensor

Project  
17

## Description:

Thermistor sensor can sense the temperature change of surroundings in real time, also will vary from temperature variation. In the circuit, it will convert the temperature variation into voltage change, and input the voltage to P2 of micro:bit board. Finally, display the analog quantity of P2 on the serial monitor.  
Note that you need to use a serial communication software, namely, Arduino IDE.

## Hardware Required:

Main Board  *1	Breadboard  *1	T-type Adapter  *1
10KΩ Resistor  *1	Thermistor  *1	USB Cable  *1
Jumper Wire  *3		

## Get Code:

```
on start
  led enable false
  forever
    serial write number analog read pin P2
    serial write line ""
  pause (ms) 200
```

## Circuit Diagram:

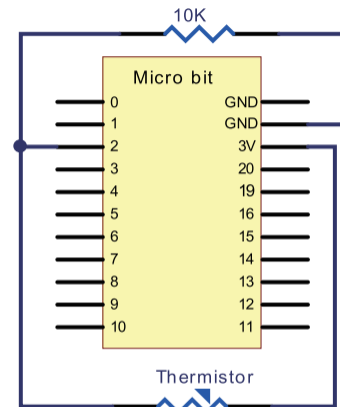

## Testing Result:

You can see the value is displayed on serial monitor. When thermistor temperature rises, the resistance will decrease, analog value increases.  
For example, when you breathe on the thermistor, its temperature will rise, so analog value increases.

## Connection Diagram:

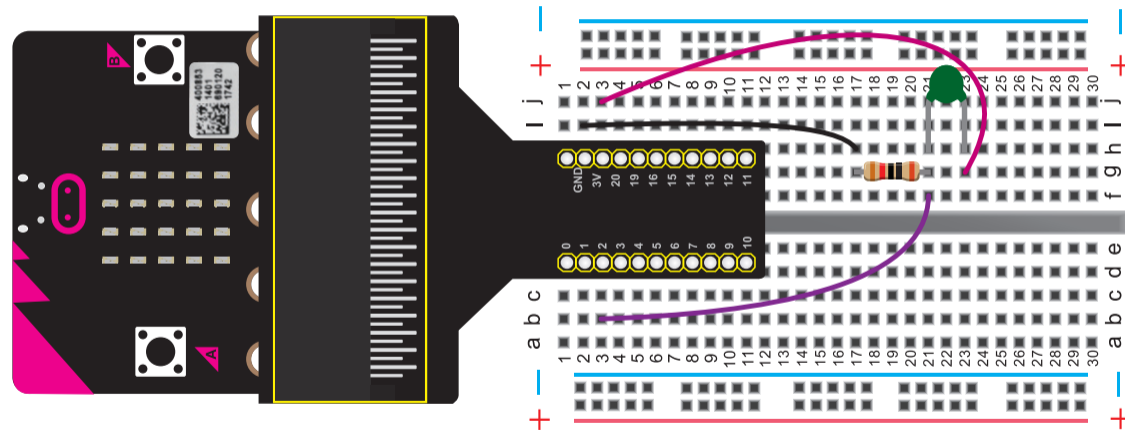

# 18b20 Temperature Sensor





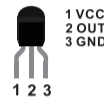

Project  
**18**

## Description:

Input its output voltage into P2 on micro:bit main board, after formula computing, display the temperature value of current surroundings on the serial monitor. In this way, we will use a serial communication software, Arduino IDE. Notice the wiring direction of LM35, or else it will damage the LM35 sensor if reversed. .



## Hardware Required:

Main Board  *1	Breadboard  *1	T-type Adapter  *1
18b20  *1	USB Cable  *1	Jumper Wire  *3

## Get Code:

```
on start
  led enable false
  forever
    set Temp to 300
    analog read pin P2
    serial write line "Temp: "
    serial write number Temp
    serial write line " C"
    pause (ms) 1000
```

## Circuit Diagram:

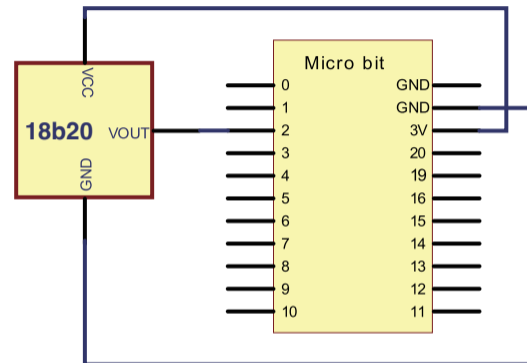

## Testing Result:

Done wiring, open Arduino IDE, set well the COM port and download the code into micro:bit. Then, open serial monitor, set the baud rate as 115200 (because micro:bit serial communication baud rate is 115200). You can see the temperature value of current surroundings on the serial monitor.

## Connection Diagram:

