

Product Specification

Water-resistant Switch Panel with Circuit Breakers

SP3116P (6 Positions)

Product Features:

- Water-proof (IP66) switch panel – protect against powerful water jets from all directions (when mounted).
- Push Button Reset circuit breakers with waterproof boots.
- Completely sealed illuminated rocker switches.
- Watertight mounting gasket included.
- 30 pcs assorted label set included.

Product Specifications:

Material:	ABS
Circuit Protection:	6-20 A Push Reset Circuit Breakers
Ratings:	DC 12V /24V Maximum Cumulative Amp: 45 A
Panel Depth:	SP3116P 75 mm
Dimensions:	SP3116P 133.4 x 173.35 mm
Mounting Dimensions:	SP3116P 97 x 153 mm
Notes:	IP66: Water projected in powerful jets against the enclosure from any direction shall have no harmful effects.

Installation Instructions

1. Disconnect all power (AC & DC).
2. Cut opening for mounting location using the template provided.
3. Connect the positive wire (red) to the DC power source (the batteries) and the LED negative feed wire (yellow) to a DC negative bus bar.
4. Connect the devices positive to the load terminals wires (red) of the switches. Connect the negative wires of the devices to a negative bus bar. Apply desirable labels to the recessed area at corresponding branches.
5. Mount the switch panel with the included self-tapping screws.
6. Reconnect all the AC & DC powers. Turn on and off all branch circuits to check if the panel works normally.

Wiring Diagram

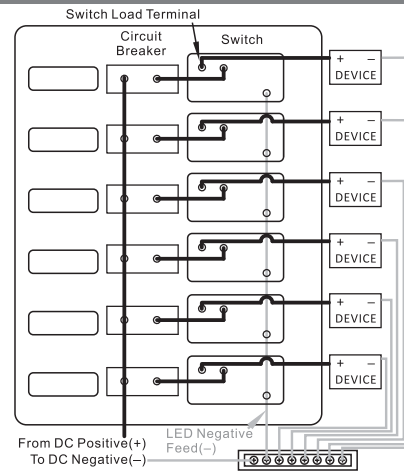

CE IP66

Mounting Template

 Screw holes

 This template is provided to help you install the switch panel correctly. Cut out template and trace onto the dashboard. Then drill a hole at the shielded area.

 Cut hole here

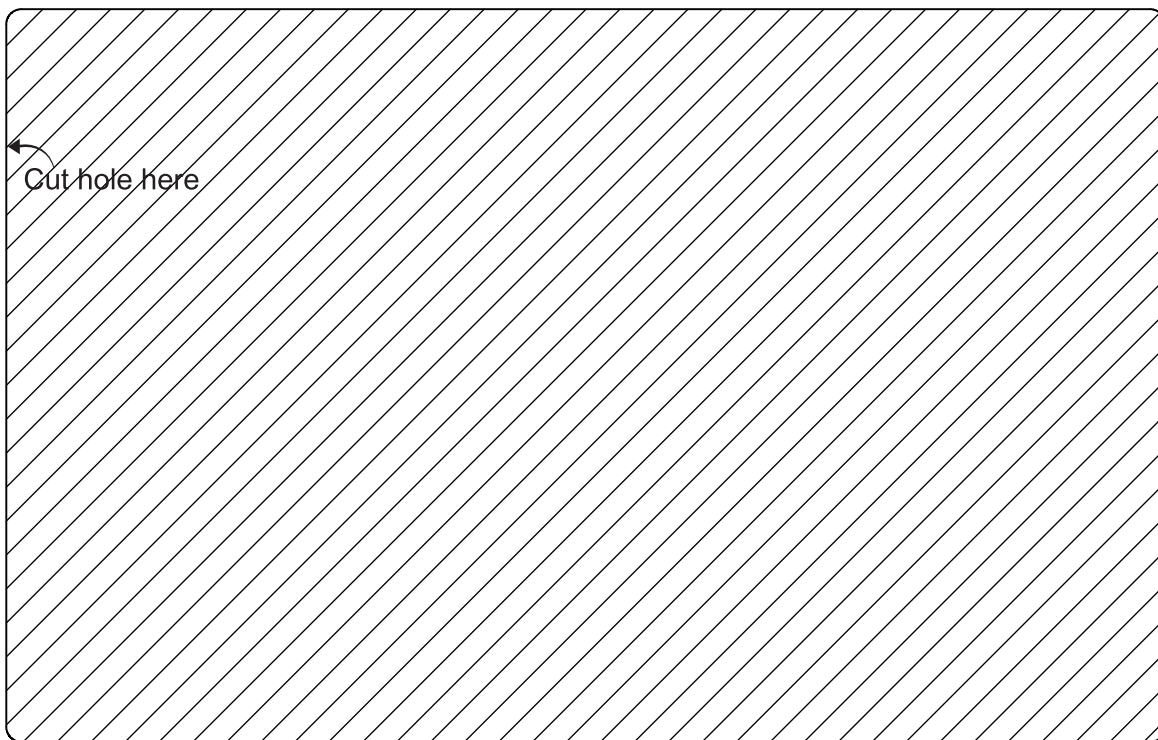

Actual Panel Size

SP3116P