

POWERTECH

SL4100

Solar Rechargeable 60W LED Flood Light



Instruction Manual

BOX CONTENTS:

Lamp

Solar Panel

Remote Controller

Support Bracket

Wall Bolts

Operating Manual

INSTALLATION:

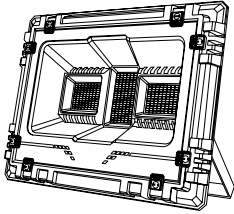

1. Take out the lamp from the packaging

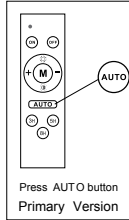

2. Press button above

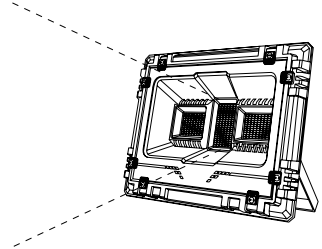

3. The light should turn on automatically

Once the Waterproof connector is connected correctly, place the Solar Panel towards the Sunlight. The light should automatically turn off and the Charging indicator (See position Below) will flash regularly. This means the Solar panels is charging the batteries correctly.

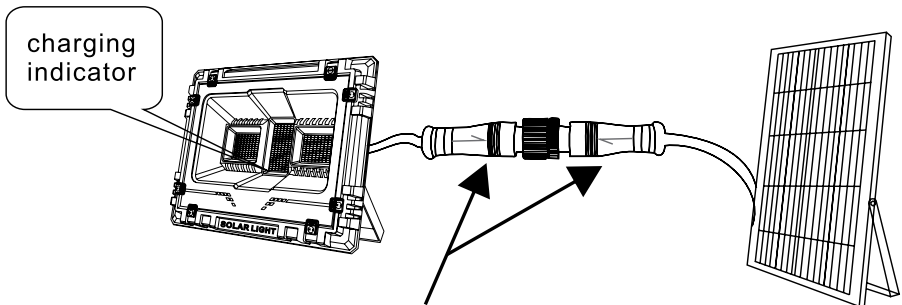

(Please use arrows on connector to align correctly)

Fix the product on the wall with supplied wall bolts. The installation height is suggested to be between 3-6 meters.

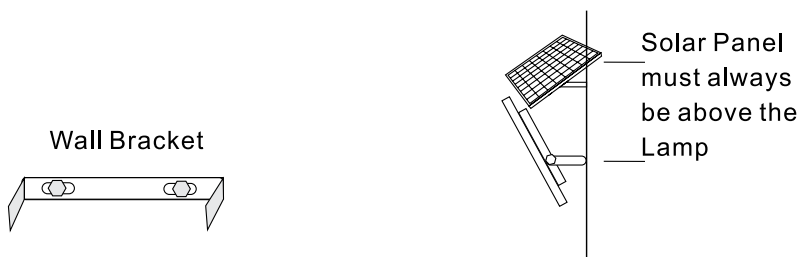

Please make sure the Solar panels are installed at the correct Angle for your Country and in the correct direction for your Hemisphere. Also ensure that the sunlight to them is not blocked by obstacles such as trees, shadows, buildings etc. The panel needs unobstructed sunlight to charge correctly.

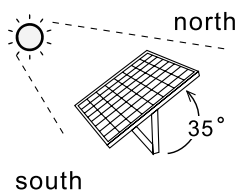

100% charging efficiency ✓

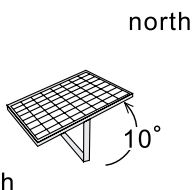

75% charging efficiency ✗

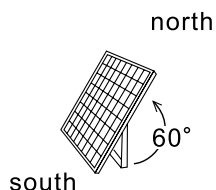

50% charging efficiency ✗

Tips:

1. Installation direction of the solar panel is 5-10 degrees south to west, an angle of 35 degrees with the horizontal plane.
2. Please also ensure that the panel is affixed firmly to a permanent structure so it is not affected by winds or movement.
3. Please use the supplied remote to select your required brightness and duration time of the light to your desired requirements. (Reserved keys on the remote are for use with other models.)

REMOTE CONTROLLER INSTRUCTIONS:

Light-operated Mode.

Once the waterproof Wiring Connector is connected and tightened, by pressing the [AUTO] key, the light will automatically turn on when darkness falls, and will turn off to charge once the sun rises.

Remote Controller Functions:

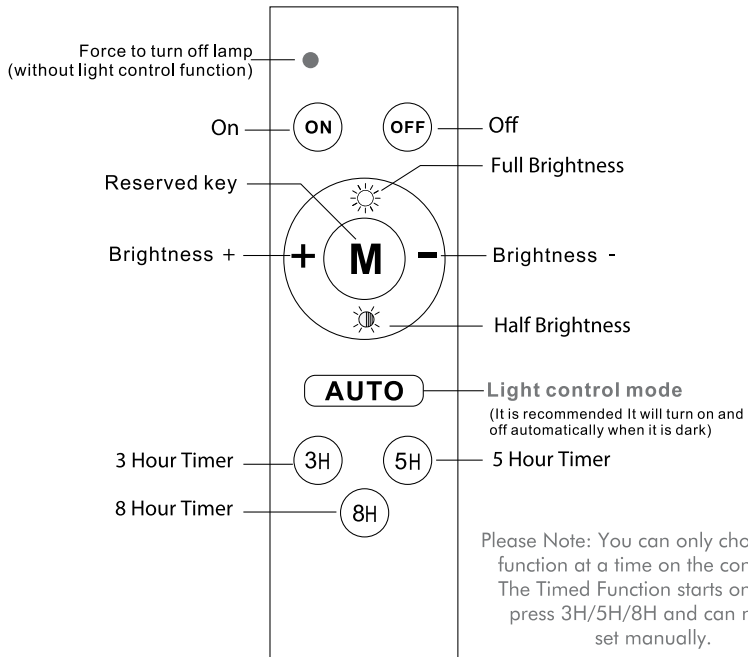

IMPORTANT NOTIFICATION:

1. Please never connect 240VAC to this unit as it will damage the lamp and very likely cause personal injury or electric shock.
2. Please ensure the Installation is affixed firmly to solid/permanent fixture so as to avoid it falling & causing injury.
3. Disassembling the Lamp,Panel or any of its parts will void the warranty immediately.
4. Please clean the Solar Panels regularly of Dust,debris and Bird dropping,as this will keep the Panels output at it's highest efficiency for charging the batteries.

Distributed by:
Electus Distribution Pty Ltd
46 Eastern Creek Dr,
Eastern Creek NSW 2766 Australia
Ph 1300 738 555
Int'l +61 2 8832 3200
Fax 1300 738 500

www.electusdistribution.com.au