

Cell Type BK-3MCC

Specifications

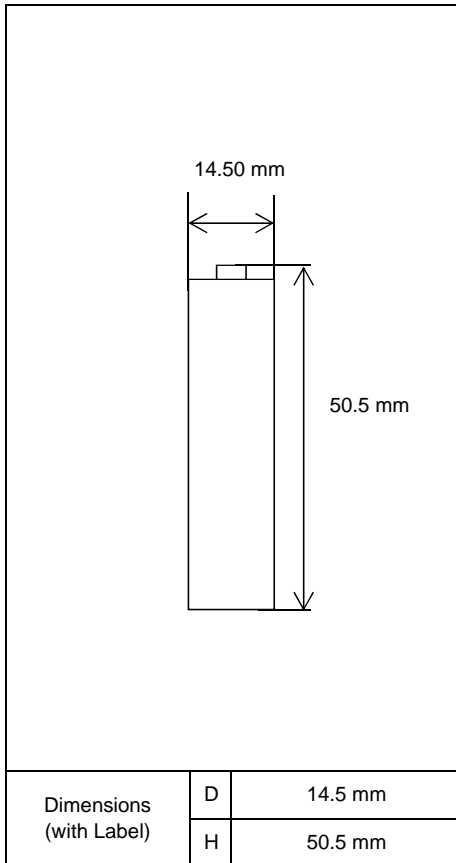

Type : Nickel-Metal Hydride Battery		Size : AA Consumer Type
Country of origin		China
Capacity ¹⁾	Minimum	1900mAh
Nominal Voltage		1.2V
Charging Current x Time	Fast Charge ²⁾	Max.1900mA
Ambient Temp.	Charge Condition	Fast Charge ²⁾
	Discharge Condition	0°C - 40°C
	Storage Condition	-5°C - 50°C
	Less than 90days	-20°C - 40°C
	Less than 1year	-20°C - 35°C
Internal Impedance ³⁾ (after discharge to E.V.=1.0V)		Approx. 25m Ω (at 1000Hz)
Weight ⁴⁾		Approx.27g
Size ⁴⁾ : (Diameter) x (Height)		14.5(D) x 50.4(H) mm

1)Single cell capacity under the following condition.

Charge : 190mA×16h, Discharge : 380mA(E.V.=1.0V) at 25°C

2)Use recommended charging system.

3)After a few charge and discharge cycles under the above 1) condition.

4)With Label.