

# CHARGER 2

## DC-DC Charger

### User Manual v3.0

#### Important Instructions

- For optimal performance, **update your unit to the latest firmware before first use.**
- Read and understand this manual before use and keep it handy for future reference.

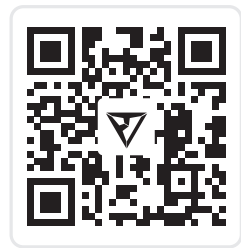

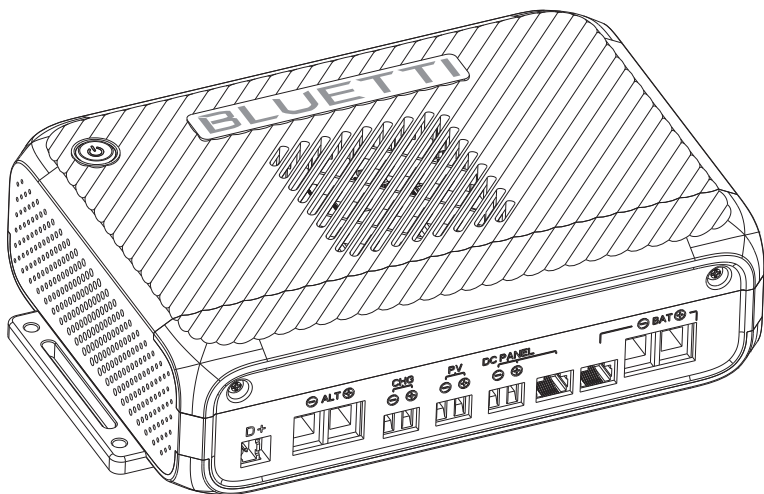

## Legal Information

### Notice

BLUETTI's products, services, and features are subject to the agreed-upon terms and conditions during purchase. Please note that some products, services, or features described in this manual may not be available under your purchase contract. Unless otherwise specified in the contract, BLUETTI makes no representations or warranties of any kind, express or implied, with respect to the contents of this manual.

The contents of this manual are subject to change without notice. Please get the latest version from: <https://www.bluettipower.com/pages/user-guides>

If you have any questions or concerns about this manual, please contact BLUETTI support for further assistance.

# Contents

<b>1</b>	<b>Safety Information</b>	<b>05</b>
1.1	Important Guidelines	05
1.2	Important Safety Instructions	05
1.3	Operation Guidelines	06
<b>2</b>	<b>Packing List</b>	<b>07</b>
<b>3</b>	<b>Get to Know Your CHARGER 2</b>	<b>09</b>
3.1	Dimensions	09
3.2	Introduction	09
3.3	Overview	11
<b>4</b>	<b>Installation</b>	<b>12</b>
<b>5</b>	<b>Wiring</b>	<b>13</b>
5.1	Connecting to BLUETTI Products	14
5.2	Connecting to Other Inputs	15
5.3	Connecting to DC Hub	16
<b>6</b>	<b>Power Button Indicator</b>	<b>17</b>
<b>7</b>	<b>Specifications</b>	<b>17</b>
<b>8</b>	<b>Troubleshooting</b>	<b>18</b>
	<b>FAQs (Frequently Asked Questions)</b>	<b>19</b>
	<b>Compliance</b>	<b>20</b>

# 1. Safety Information

Before using this product, please read the manual carefully and follow all safety instructions. Pay close attention to the **Warnings, Attentions, Cautions, Notes**, and other safety labels in the manual and on the product itself. If you have any questions or encounter a situation not addressed in this manual, please contact us. Improper use or unauthorized operation may result in damage or injury, which is not covered by the warranty.

## 1.1 Important Guidelines

For optimal performance and safety, please follow these essential guidelines:

- Read all instructions and warnings for the CHARGER 2, car battery, and BLUETTI products.
- Always operate and store the product in the conditions specified in this manual.
- Ensure the product is used in compliance with all relevant standards and regulations.
- Use a standard 12 V or 24 V car battery, or two 12 V batteries connected in series.
- Make sure the product's output voltage falls within the portable power station's DC input voltage.
- Warning: Use conductors with insulation rated for at least 80°C (176°F). Base the conductor ampacity on a maximum termination temperature of 120°C (248°F).

**BLUETTI is not liable for the following situations or any resulting consequences:**

- Damage caused by natural disasters, including earthquakes, fires, floods, storms, or mudslides.
- Damage that occurs during customer-handled transportation.
- Issues caused by improper storage or use outside the conditions specified in this manual.
- Damage caused by customer negligence, misuse, or intentional harm.
- Damage caused by third-party actions, including improper handling, usage, or installation not in line with this manual.
- Damage or issues caused by unauthorized adjustments, modifications, or removal of product labels.
- Damage or negative outcomes resulting from powering non-BLUETTI products.
- Accidents or safety concerns arising from using the product in critical applications, such as nuclear, aviation, or medical fields, where high reliability is essential for personal safety or operation.

## 1.2 Important Safety Instructions

Save these instructions – This manual contains important safety instructions.

- **WARNING** – A battery can present a risk of electrical shock, burn from high short-circuit current, fire or explosion from vented gases. Observe proper precautions.
- **WARNING** – This unit employs components that tend to produce arcs or sparks – to prevent fire or explosion, do not install in compartments containing batteries or

flammable materials.





- **WARNING** – Disconnect all power sources before performing any electrical work.
- **CAUTION** – To reduce the risk of fire, use only battery packs that include the battery management system and all necessary protection for the battery pack integral to the pack.
- **CAUTION** – To prevent fire, do not cover or obstruct ventilation openings. Do not mount in zero-clearance compartment. Overheating may result.
- Proper disposal of batteries is required. Refer to your local codes for disposal requirements.
- Replace only with same type and ratings of fuse.
- Always turn off the vehicle before installation or any electrical work.
- Do not clean the product with water.
- Keep the product away from heat sources and high temperatures.
- Never use the product near open flames, explosive gases, or in environments with smoke, vapors, or other hazardous conditions.
- Do not store or use the product in environments with salt fog or high humidity.
- Do not contact with any metal tools or objects while the product is in operation.
- Always ensure the product is completely dry before use.
- Store and use the product in a cool, dry place with good ventilation.
- Do not open or modify the product yourself. Only qualified personnel should perform repairs or replace parts using BLUETTI-approved components and cables to prevent the risk of fire, electric shock, or other personal injury.
- Stop using the product immediately in case of malfunction.
- Regularly inspect the product and its accessories for damage or deterioration. If the product's shell is cracked, do not use it and contact BLUETTI support or your local BLUETTI dealers.
- Keep the product out of reach of children and pets.

### **1.3 Operation Guidelines**

- Securely tighten all screws.
- Before powering on, make sure the positive and negative terminals are connected correctly to prevent reverse polarity.
- Connect the cables to CHARGER 2 first, then to the car battery.
- Ensure the product is firmly installed before use.

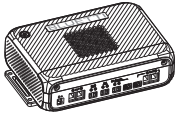
## 2. Packing List

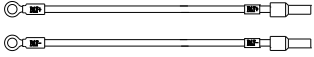
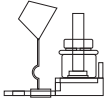
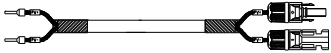
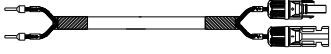
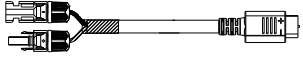

### Standard Accessories\*

Item	Picture
CHARGER 2 DC-DC Charger	
Self-tapping Screw × 6	
Car Battery Cables** (5 m/16.4 ft, 6 AWG)	
75 A Fuse**	
MC4 Input Cable (200 mm/7.87 in)	
MC4 Output Cable (200 mm/7.87 in)	
Solar Charging Cable (MC4 to XT60, 0.5 m/19.685 in)	
Documents	
Bidirectional Power Cable (0.65 m/2.13 ft, for B230, B300K, B300, AC200MAX, AC200L, Apex 300, B500K)	

\*See Section 3.2 and Chapter 5 for wiring details.

\*\*Included with the Pro Package only.

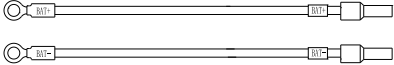
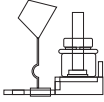
The following optional accessories are not included. You can purchase accessories at <https://www.bluettipower.com/>

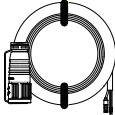
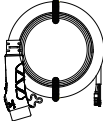
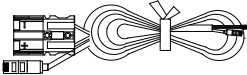
Item	Picture
Car Battery Cables (8 m/26.25 ft, 6 AWG)	
75 A Fuse	
D+ Signal Wire (5 m/16.4 ft, for smart alternator)	
Bidirectional Power Cable (0.65 m/2.13 ft, for B210, AC240)	
Bidirectional Power Cable (0.65 m/2.13 ft, for B300S)	
Bidirectional Power Cable (0.52 m/1.706 ft, for FridgePower)	

**Note:** For input cable or fuse replacement, contact BLUETTI support. These tasks should be performed by a qualified technician only.

Recommended wire gauge: 6 AWG

Fuse rating: 75 A

## 3. Get to Know Your CHARGER 2

### 3.1 Dimensions

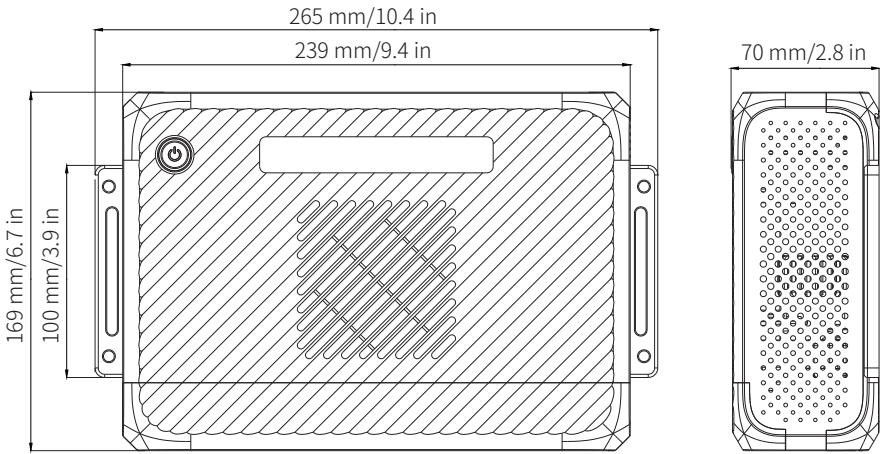

### 3.2 Introduction

The CHARGER 2 delivers high-speed, on-the-go charging for BLUETTI power stations and compatible battery packs. It draws excess power from your vehicle's alternator, paired with solar panels or battery packs like the B300K, for up to 1,400 W input. When paired with the DC Hub, it provides reliable power for DC devices in your vehicle. Smart power switching keeps you running — when your connected battery runs low, it automatically recharges from the alternator or solar. If your car battery drops, it reverses to recharge it using solar or BLUETTI products.

Use the BLUETTI app to monitor and adjust charging in real time. For details, refer to the *CHARGER 2 App User Manual*.



### 3.3 Overview

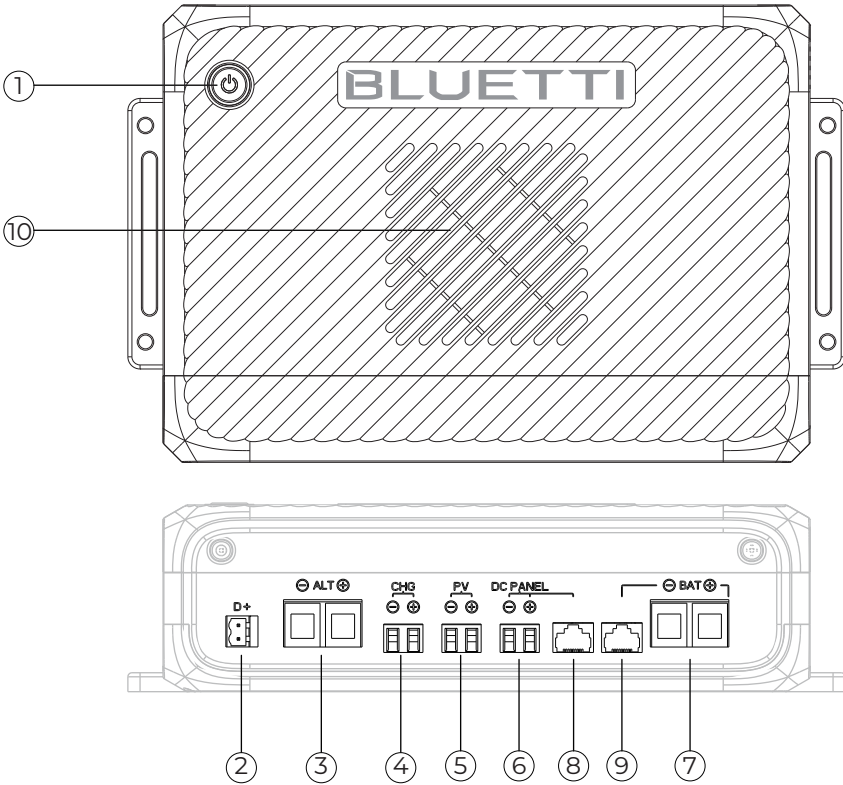

- ① Power Button\*
- ② D+ Signal Port
- ③ Car Battery Input/Output (ALT)
- ④ Power Station Output (CHG)
- ⑤ Solar Input (PV)
- ⑥ 48 V DC Panel (DC Hub) Port
- ⑦ Bidirectional Power Port (BAT)\*\*
- ⑧ 48 V DC Panel (DC Hub) COM Port
- ⑨ BLUETTI Product COM Port
- ⑩ Vent

\*When input power is connected, it starts breathing green. Without an input source, the button won't respond and the unit won't power on. See Chapter 7 for indicator details.

\*\*Only for BLUETTI products.

## 4. Installation

Install the CHARGER 2 inside the vehicle's cabin or trunk, close to the portable power station. Choose a dry area free from other substances and not susceptible to high temperatures.

**Step 1:** Select an appropriate location, leaving at least 20 cm (7.87 in) of clearance on all sides of the CHARGER 2.

**Step 2:** Secure the CHARGER 2 in place with four self-tapping screws.

### Attention:

- Do not position the vent facing upward to prevent obstruction and ensure proper airflow.
- Insufficient ventilation may lower performance or trigger overheat protection.

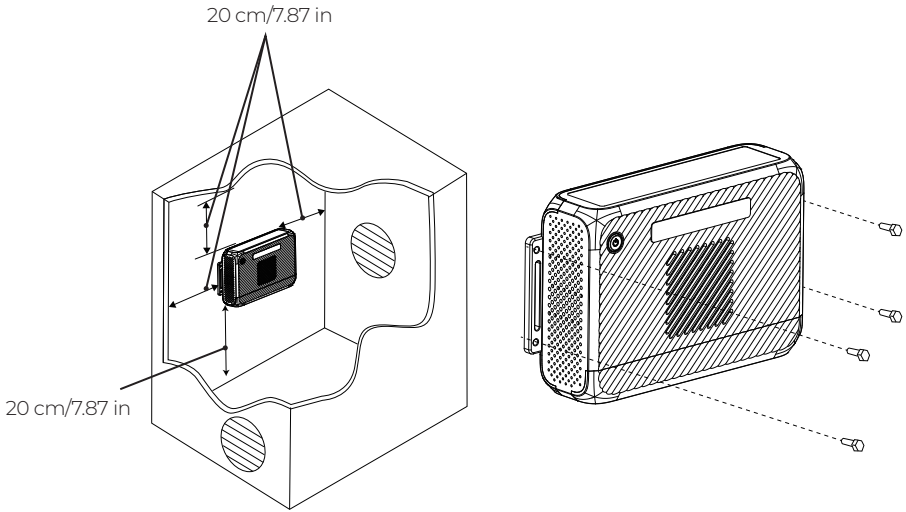

## 5. Wiring

### Safety Instructions

- Have a qualified professional handle all wiring.
- Wear protective gear such as safety goggles and gloves during operation.
- Route cables away from heat, sharp edges, and friction points. Secure them to prevent damage or loose connections.
- Always follow the battery manufacturer's safety instructions during installation.
- Do not start the vehicle or power on the unit until all wiring is complete and verified.
- Turn off the unit and disconnect it from all devices before making any wiring changes.
- When using solar panels, ensure their open-circuit voltage is within the power station's DC input range.
- Be sure to match the positive and negative terminals correctly to avoid device damage.
- Tighten the screws with a torque of about **1 N·m**.

### Preparation

- Make sure the vehicle is not started and its battery is in good condition.
- Ensure the vehicle battery is either a standard 12 V or 24 V, or two 12 V batteries connected in series.
- Ensure that the BLUETTI products are compatible with CHARGER 2.
- Prepare a Phillips screwdriver and the required connection cables.

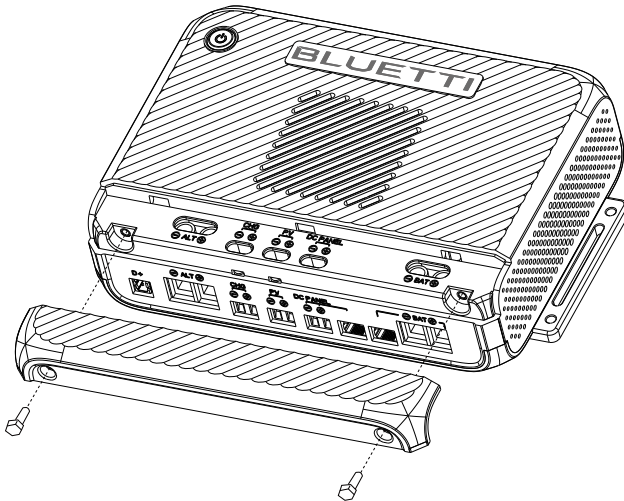

## Operation

**Step 1:** Remove the bottom screws and lift off the top cover.

**Step 2:** Loosen the screws above the ports to access the mounting holes.

**Step 3:** Connect the cables to CHARGER 2, then tighten the screws firmly to secure them.

**Step 4:** Install the fuse.

**Step 5:** Connect to the car battery.

**Step 6:** Reattach the top cover.

**Step 7:** Double-check all connections.

**Step 8:** Start the vehicle.

**Note:** You can check the charging status on the power station's display or in the app.

### 5.1 Connecting to BLUETTI Products

#### Via CHG (Power Station Output)

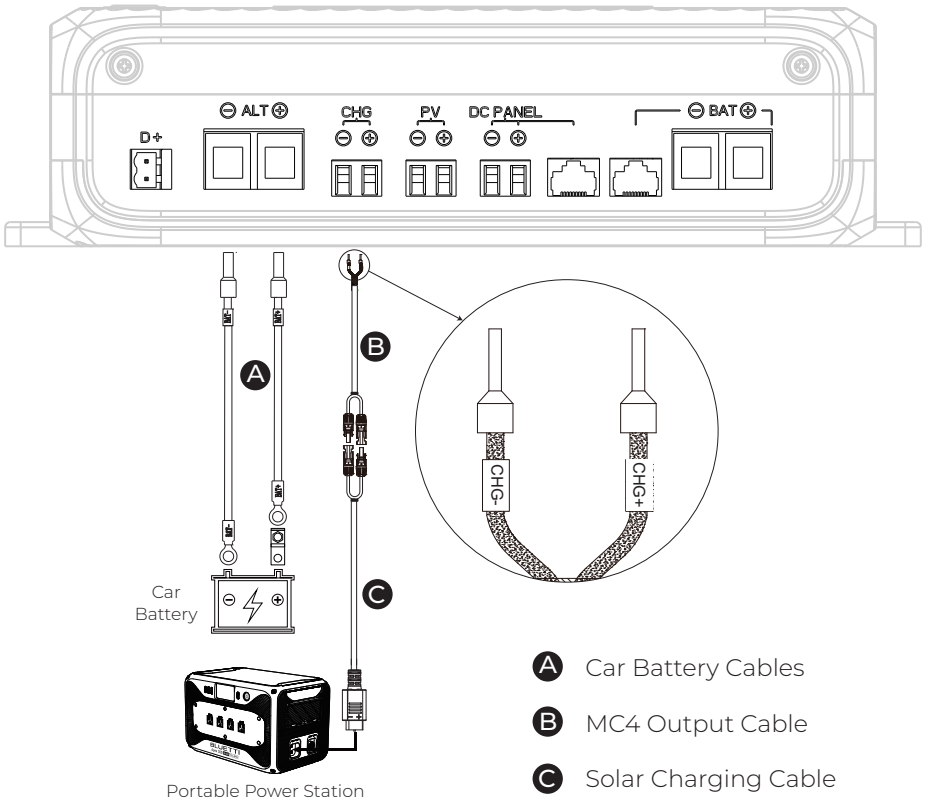

## Via BAT (Bidirectional Power Port)

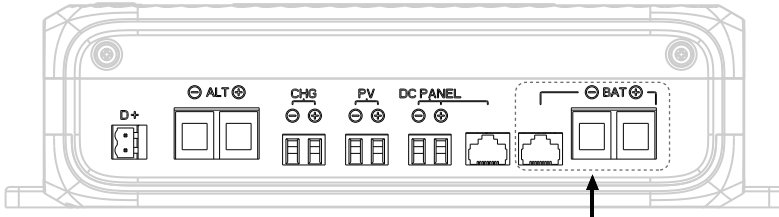

**D E F G**

Bidirectional Power Cables

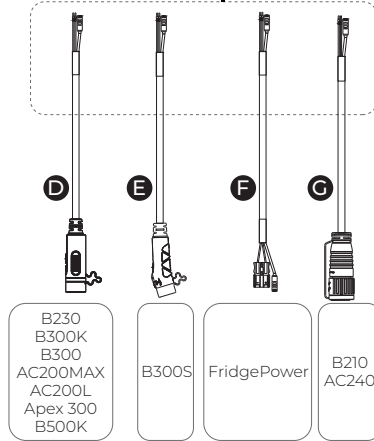

## 5.2 Connecting to Other Inputs

### Solar Panel

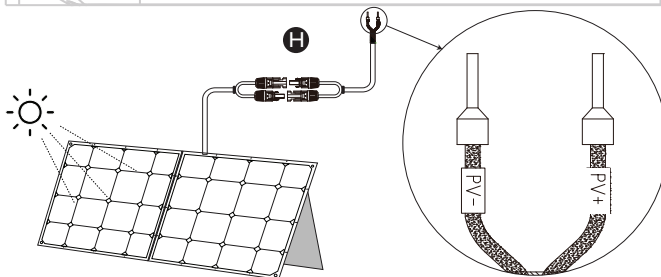
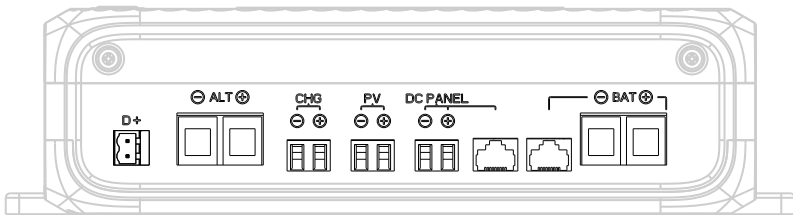

Solar Panel

**H** MC4 Input Cable

## Smart Alternator

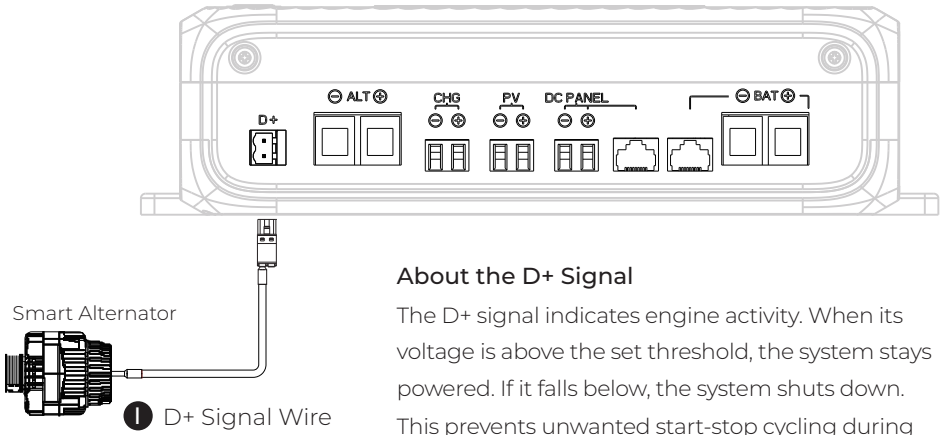

### About the D+ Signal

The D+ signal indicates engine activity. When its voltage is above the set threshold, the system stays powered. If it falls below, the system shuts down. This prevents unwanted start-stop cycling during quick pauses for smoother, more stable operation.

## 5.3 Connecting to DC Hub

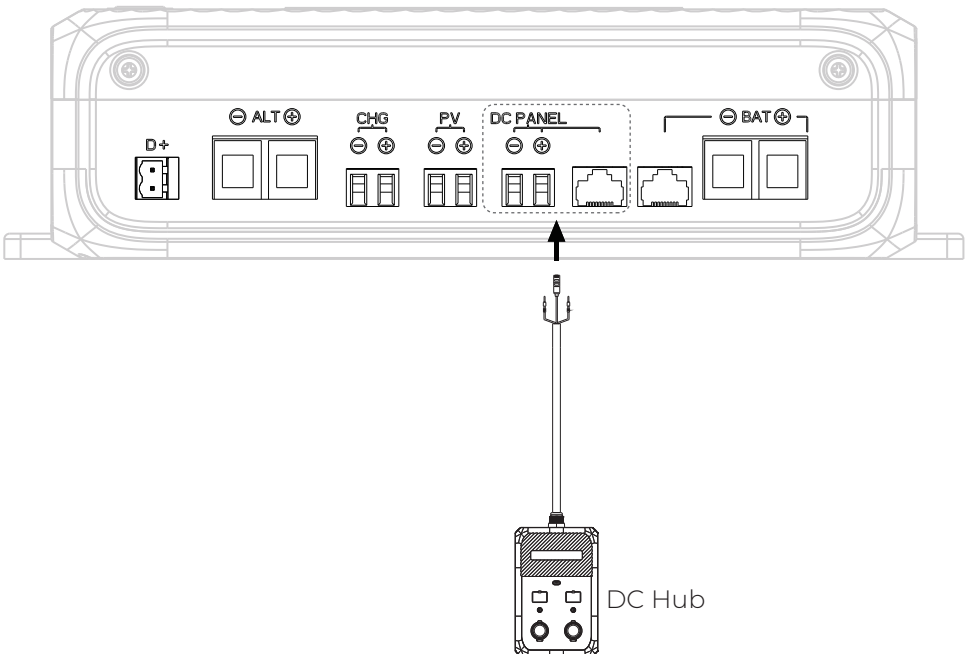

## 6. Power Button Indicator

Status	Description
Breathing green	Standby
Steady green	Normal Operation
Flashing red	Alarm
Steady red	Non-recoverable fault

## 7. Specifications

Model	CHARGER 2
Dimensions (L × W × H)	265 × 169 × 69.7 mm/10.43 × 6.65 × 2.74 in
Weight	1.59 kg/3.51 lbs
Operating Temperature	-20°C to 60°C/-4°F to 140°F (Power decreases above 40°C/104°F)
Storage Temperature	-20°C to 60°C/-4°F to 140°F
Operating Humidity	10% to 90%
Noise Level	50 dB Max.
Operating Altitude	< 2,000 m/6,561 ft
Protection Rating	IP20
Car Battery Input/Output (ALT)	800 W, 12.8 V==62.5 A, 25.6 V==31.3 A
Bidirectional Power Port (BAT)	1,000 W, 19.2 V==52 A, 25.6 V==39 A, 51.2 V==19.5 A
Solar Input (PV)	600 W, 13 V–50 V==20 A
Power Station Output (CHG)	1,200 W, 12 V–56 V==24 A
48 V DC Panel (DC Hub) Port	600 W, 40 V–58.5 V==12.5 A

## 8. Troubleshooting

Error Code	Description	Solutions
G001	Input overvoltage	Make sure the solar panel's open-circuit voltage is between 13 V and 50 V.
G002	Pre-charge fault	Please contact BLUETTI support for assistance.
G003	Input overcurrent	<ol style="list-style-type: none"> <li>1. Check the ports for any damage or foreign objects.</li> <li>2. Inspect the cables for signs of damage.</li> </ol>
G004	Output short circuit	<ol style="list-style-type: none"> <li>1. Check the ports for any damage or foreign objects.</li> <li>2. Inspect the cables for signs of damage.</li> <li>3. Check if the DC Hub is damaged.</li> </ol>
G005	Output undervoltage	<ol style="list-style-type: none"> <li>1. Check the ports for any damage or foreign objects.</li> <li>2. Inspect the cables for signs of damage.</li> <li>3. Check if the DC Hub is damaged.</li> </ol>
G006	Output overvoltage	Please contact BLUETTI support for assistance.
G007	Overtemperature	<ol style="list-style-type: none"> <li>1. Disconnect all loads. Check if the fan is not spinning or obstructed by foreign objects.</li> <li>2. Make sure the vent is clear.</li> <li>3. Do not use or store the CHARGER 2 in environments above 60°C (140°F).</li> </ol>
G008	Output overload	<ol style="list-style-type: none"> <li>1. Check the output ports for any damage or foreign objects.</li> <li>2. Inspect the output cables for signs of damage.</li> <li>3. Check if the DC Hub is damaged.</li> </ol>

Check the app for error details and recommended solutions. If the issue persists, stop using the product immediately and contact BLUETTI support for assistance.

## FAQs (Frequently Asked Questions)

**Q1: When should I use Reverse Charging or Maintenance Mode?**

**A:** Reverse Charging quickly tops up a depleted or low car battery in an emergency, while Maintenance Mode provides a low-current, continuous charge for daily battery care.

**Q2: Will installing the CHARGER 2 affect my vehicle's warranty?**

**A:** To ensure your warranty remains valid, please check with your vehicle manufacturer before installation.

**Q3: Tips for maintaining the CHARGER 2**

**A:** To keep the CHARGER 2 in good condition:

- a. Regularly check and tighten the screws.
- b. Keep it clean and dry.
- c. Ensure proper ventilation.

**Q4: Which type of vehicle battery can power the CHARGER 2?**

**A:** Use a standard 12 V or 24 V vehicle battery, or two 12 V batteries connected in series.

# Compliance

## • FCC Statement

This device complies with part 15 of the FCC Rules. Operation is subject to the following two conditions:

- (1) This device may not cause harmful interference.
- (2) This device must accept any interference received, including interference that may cause undesired operation.

This equipment has been tested and found to comply with the limits for a Class B digital device, pursuant to part 15 of the FCC Rules. These limits are designed to provide reasonable protection against harmful interference in a residential installation. This equipment generates, uses and can radiate radio frequency energy and, if not installed and used in accordance with the instructions, may cause harmful interference to radio communications. However, there is no guarantee that interference will not occur in a particular installation. If this equipment does cause harmful interference to radio or television reception, which can be determined by turning the equipment off and on, the user is encouraged to try to correct the interference by one or more of the following measures:

- Reorient or relocate the receiving antenna.
- Increase the separation between the equipment and receiver.
- Connect the equipment into an outlet on a circuit different from that to which the receiver is connected.
- Consult the dealer or an experienced radio / TV technician for help.

**FCC Caution:** Any changes or modifications not expressly approved by the party responsible for compliance could void the user's authority to operate this equipment.

## IMPORTANT NOTE: FCC Radiation Exposure Statement

This equipment complies with FCC radiation exposure limits set forth for an uncontrolled environment. This equipment should be installed and operated with a minimum distance of 20cm between the radiator and your body.

## • IC Caution

This device contains licence-exempt transmitter(s) / receiver(s) that comply with Innovation, Science and Economic Development Canada's licence-exempt RSS(s). Operation is subject to the following two conditions:

- (1) This device may not cause interference.
- (2) This device must accept any interference, including interference that may cause undesired operation of the device.

**RF exposure statement:** The equipment complies with ISED Radiation exposure limits set forth for uncontrolled environments. This equipment should be installed and operated with a minimum distance of 20cm between the radiator and your body.

L'émetteur/récepteur exempt de licence contenu dans le présent appareil est conforme aux CNR d'Innovation, Sciences et Développement économique Canada applicables aux appareils radio exempts de licence. L'exploitation est autorisée aux deux conditions suivantes:

- (1) L' appareil ne doit pas produire de brouillage;
- (2) L' appareil doit accepter tout brouillage radioélectrique subi, même si le brouillage est susceptible d' en compromettre le fonctionnement.

**Déclaration d'exposition aux RF :** L'équipement est conforme aux limites d'exposition aux rayonnements ISDE définies pour les environnements non contrôlés. Cet équipement doit être installé et utilisé avec une distance minimale de 20 cm entre le radiateur et votre corps.

CAN ICES (B)/NMB (B)

## Need Help? We're here for you!

☎ +1 909-570-0909

Mon-Sat, 06:00-17:00 (PDT)

✉ [service@bluettipower.com](mailto:service@bluettipower.com)



@ BLUETTI Official



@ bluetti\_inc



@bluetti.inc



@bluetti.inc

## Visit Us

**BLUETTI Power Inc.**

6185 S Valley View Blvd, Ste D, Las Vegas, NV 89118, US

## Warranty Card

Manufacture Date .....

Sale Date .....

File No. ....

Manufacturer .....

## Warranty Instructions

1. The product comes with a 24-month warranty.
2. After-sale support: [service@bluettipower.com](mailto:service@bluettipower.com)
3. The warranty does not cover:
  - a. Damage caused by incorrect use, unauthorized repair, or disassembly.
  - b. Damage resulting from fire or force majeure events.
  - c. Lack of a clear, complete warranty card with the sales company seal.



**BLUETTI**

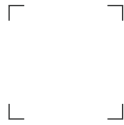

## Certificate

Inspector: \_\_\_\_\_

QC: \_\_\_\_\_

Always Share Excellence