

POWERTECH

MB3764

12V 850A Jump Starter and Powerbank with 10W Wireless Qi Charger



Instruction Manual

CONTENTS

Warnings & Safety Information	3
Before First Use	4
Box Contents	4
Product Diagram.....	5
Operation Details.....	6
Clamp Performance.....	7
Operation Instructions.....	8
Troubleshooting.....	10
Warranty Information.....	12

WARNINGS & SAFETY INFORMATION

WARNING: The manufacturer is not responsible for any potential injury from misuse

- After starting your vehicle, remove the Jump Starter as soon as possible
- DO NOT connect the 2 alligator clip together.
- DO NOT disassemble the Jump Starter
- Do not use the product in bathroom or other damp places or places near the water.
- Do not remodel or dismantle the device.
- Keep the product away from the children.
- Do not reverse the connections of output or input.
- Do not throw the product into fire.
- Please don't use the charger whose charging voltage is more than the product to charge.
- The temperature should be kept between 0°C to 40°C when the device is being charged.
- Do not hit or throw the product.
- If there is problem with charging, please contact your dealer.
- Keep the product away from the flammable objects (Bed or carpet)
- If the liquid of the device is splashed into eyes, do not wipe the eyes but wash them with clean water immediately.
- If the product is heating and discolouring, please stop using, as it may lead to liquid, smoke and burn.
- After long term storage or not in use, please ensure that devices will be charged and discharged in every three months.

BEFORE FIRST USE

Prior to using your product, please read all the safety and operating instructions thoroughly. Please ensure you follow the steps below before using the product. We recommend you keep the original packaging for storing the product when not in use.

Please pay close attention to the section entitled Warnings & Safety Information. Find a safe and convenient place to keep this instruction manual for future reference.

Unpack the product but keep all packaging materials until you have made sure your new product is undamaged and in good working order. Ensure you have all accessories listed in this manual.

BOX CONTENTS

1 x Jump Starter and Power Bank

1 x Battery Clamp

PRODUCT DIAGRAM

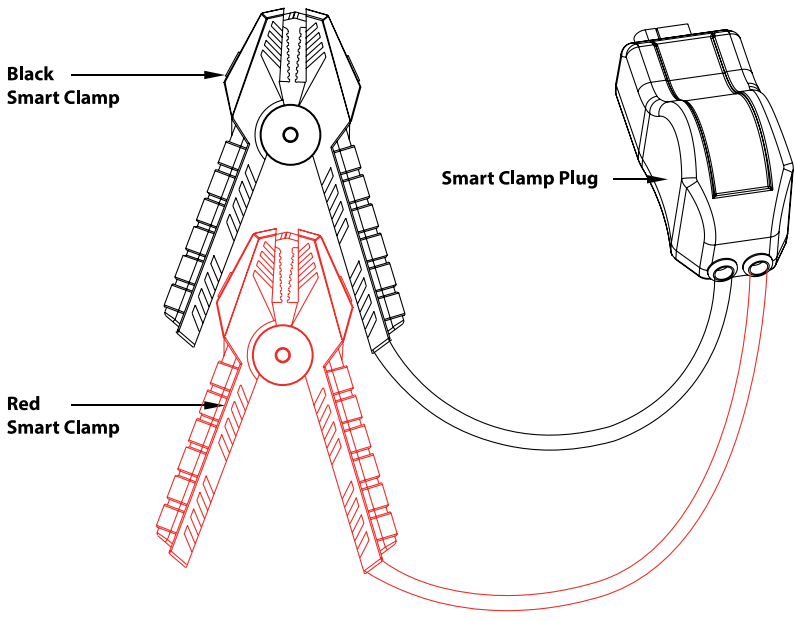
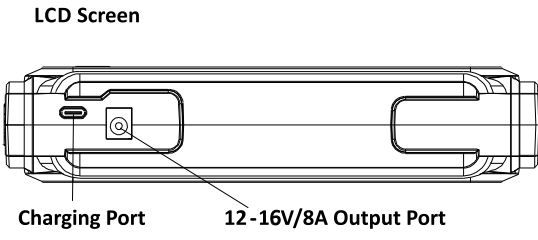
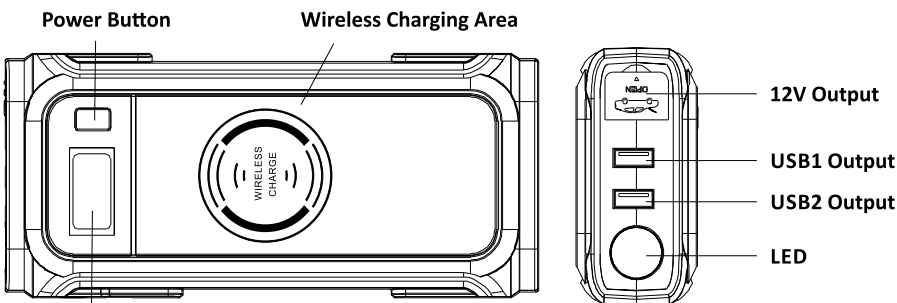

OPERATION DETAILS

1. Plug the cable connector into the car jump starter

- **Red Light On**
 - The voltage of jump starter cannot support to start
 - Check voltage of Jump Starter
- **Red and Green Light Flash**
 - Please check the voltage of jump starter belong to 12V/16V
 - Go to Step (2)

2. Connect the jump starter to the car battery

- **Red Light on and Buzzer**
 - Short Circuit
 - Disconnect the jump starter and car battery, go back to step 1.
- **Red Light on and Buzzer**
 - Reverse Polarity
 - Disconnect the jump starter and car battery, go back to step 1.
- **Red and Green light flash within 1-35 and then the Green Light on**
 - Working Status
 - Turn on the Key

3. Green Light On

- **Red Light Flashes**
 - Cannot start within 30S
 - If you need to repeat use, disconnect and reconnect the connector

CLAMP PERFORMANCE

ITEM	INDICATION	STANDARD	DESCRIPTION
High Voltage Protection	Red Light Flashing	$>16.7V(+3\%)(4S)$	Please check the voltage of Jump Starter port when you ready to used, High Voltage like $> 16.7V$ may cannot started. Tips:The Red lights of battery clamp will keep flashing.
Low Voltage Protection	Red Light Flashing	$<12.8V(\pm 3\%)(4S)$	Please check the voltage of Jump Starter port when you ready to used, High Voltage. Tips: The Red lights of battery clamp will keeping flashing.
Startup		$30S\pm 2\%$	
Start Current		$600A\pm 10\%$	0.1-0.3S 1000A 0.55 800A 25 600A
Reverse Charging Protection	Red and Green Light Flashing	Support	If there is any reverse current, The clamps will turn off the output Automatically. Tips: The Red and Green lights of battery clamp will keeping flashing.
Short-Circuit Protection	Red Light Flashing	Support	When the Two Clamps are connected, The battery clamp will be in a Short Circuit Protection Mode. Tips: The red lights of battery clamp will keep flashing, the buzzer will sound, no output and sparks.
Reverse Polarity Protection	Red Light Flashing	Support	When the Clamps are reverse connected to the car battery,The battery clamp will be in a Reverse Polarity Protection Mode. Tips: The Red lights of battery clamp will keeping flashing,the buzzer will sound, no output and sparks.
High Temperature Protection	Red Light Flashing	Support	Clamps will be cut off automatically when operation temperature is too high. Tips: Protection temperature: $80^{\circ}C \pm 5^{\circ}C$
Working Status	Green Light On	Support	The Jump Starter is ready to start the car
Standby		Support	The Red and Green lights of battery clamp will be keeping flashing when ready to use.

OPERATION INSTRUCTIONS

Charging Your Jump Starter

You can charge your Jump Starter one of two ways:

1. Using the supplied mains plug pack.

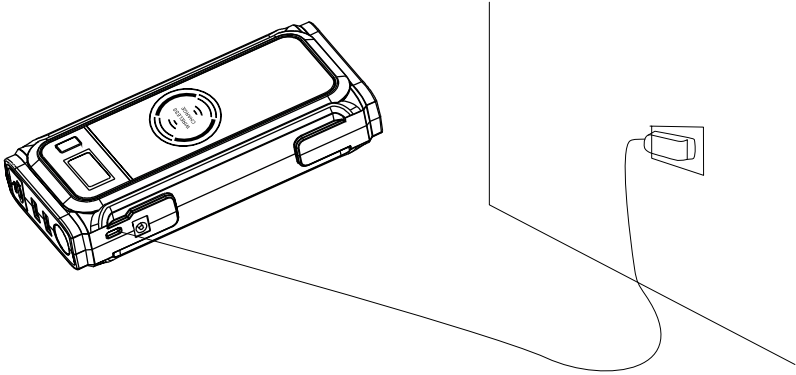

2. Insert one end of cigarette lighter charger into the 12V auxillary power outlet in your vehicle insert the other end of cigarette lighter charger into the device.

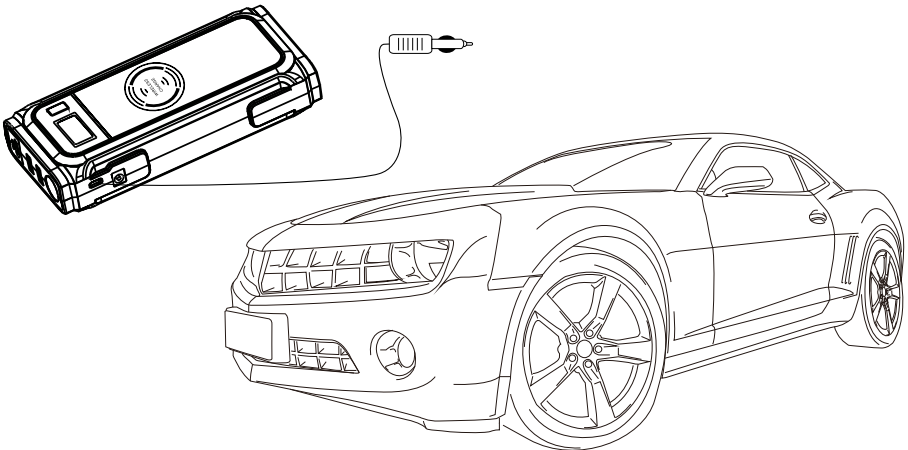

NOTE: Charging takes up to 5 hours using either charging option.

Starting your vehicle

Please ensure that your Jump Starter is no less than 50% charged. If it is below 50%, you may not be able to jumpstart your vehicle.

1. Connect the jumper lead to your Jump Starter.
2. Connect the +(red clip)to the + on your car battery.
3. Connect the -(black clip)to the - on your car battery.
4. Turn your key to start your vehicle.
5. Once your vehicle is started, disconnect the alligator clip as soon as possible.

NOTE: After starting your vehicle, remove the Jump starter as soon as possible.

WARNING: Do not connect the 2 alligator clip together.

WARNING: Do not disassemble the Jump Starter

Turning on your Jump Starter

Press the power button. Your jump starter now ready to use.

Charging devices via USB

1. You can either use the provided USB Break out lead or your own USB cable suitable for your digital device.
2. Connect either cable to the Jump Starter.
3. If using the provided USB Break out lead, Select the correct connection for your device.

How to use the LED torch

1. Double press the power button, LED light will turn on.
2. Press the button again will activate the strobe function.
3. Press the button again will activate the sos function.
4. Press the button again will turn off the light.

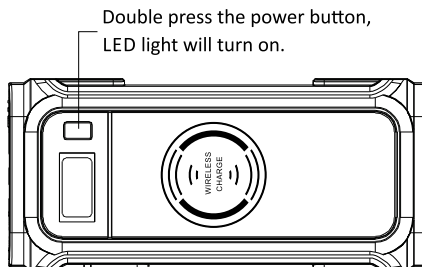

Charging indicator

1. Press the power button to see the charge status of the Jump Starter LCD screen.
2. When charging, the LCD screen will show the specific number range from 0 to 100%.
3. The input function will stop once the jump starter is fully charged.

Wireless charging

Your Jump Starter is charging ready. You can charge a smart device wirelessly from your Jump Starter. Please make sure your device can be support to be charged wirelessly before using this feature. If your device doesn't support, it will not able to charge wirelessly from the jump starter.

1. Press the power button.
2. Place your device on the wireless charging area on the jump starter.
3. Your device will now charge wirelessly.

Running a 12V device

Your Jump Starter is capable of running 12V device.

TROUBLESHOOTING

ISSUE	LIKELY CAUSE	SOLUTION
The power capacity of the device is shown in 100%, but did not fullycharged in charging process.	The battery shown 100% in the LCD Screen of Jump Starter on means stop charging, and this situation means it is semi-state of charge, which is conducive to long-term storage when the device is not in use for long time.	Pull out the charge plug, then reinsert.
Nothing happens when pressing the switch button.	Low voltage protection of the device is started and the device can not be turned on.	Insert the charger plug into the 9V2A input port to activate.

FREQUENTLY ASKED QUESTIONS

How do I turn off the Jump Starter?

Press the button for 5s, the jump starter will turn off.

How long does a full charge take?

A full charge will take between 3-5 hours using either the mains or DC charging options.

How many times can I jump start my vehicle?

This depend on the different displacements and vehicle engine. The Jump Starter can start a vehicle up to 30 times.

If not being used, how long can the Jump Starter be stored?

It is recommended to charge the Jump Starter every 3-6 months. Once the unit drops below 50% we recommend you charge it to ensure you can jump starter your vehicle.

The Jump Starter won't start my car, Why not?

- Please ensure the unit is charged above 50%.
- Ensure the clamps are secure and not connected incorrectly.
- Ensure the battery terminals are clean and free from corrosion. if corroded, clean them and reconnect the Jump Starter as per the instruction in this manual.

WARRANTY INFORMATION

Our product is guaranteed to be free from manufacturing defects for a period of 12 Months.

If your product becomes defective during this period, Electus Distribution will repair, replace, or refund where a product is faulty; or not fit for intended purpose.

This warranty will not cover modified product; misuse or abuse of the product contrary to user instructions or packaging label; change of mind and normal wear and tear.

Our goods come with guarantees that cannot be excluded under the Australian Consumer Law. You are entitled to a replacement or refund for a major failure and for compensation for any other reasonably foreseeable loss or damage. You are also entitled to have the goods repaired or replaced if the goods fail to be of acceptable quality and failure does not amount to a major failure.

To claim warranty, please contact the place of purchase. You will need to show receipt or other proof of purchase. Additional information may be required to process your claim.

Any expenses relating to the return of your product to the store will normally have to be paid by you.

The benefits to the customer given by this warranty are in addition to other rights and remedies of the Australian Consumer Law in relation to the goods or services to which this warranty relates.

This warranty is provided by:

Electus Distribution

Address 46 Eastern Creek Drive, Eastern Creek NSW 2766

Ph. 1300 738 555