

***POWERTECH***



**Ultra High Capacity 1000A 12/24V  
Lithium Jump Starter  
MB-3759  
User Manual**



Thank you for choosing this 12V/24V Jump Starter.  
Please take some time to familiarize yourself with the instructions before trying out this product. You may need to keep this manual for future reference.

## MAIN FEATURES

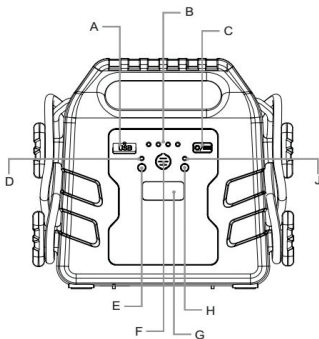

1. Intelligently detect voltage of your car battery.
2. Ultra high capacity jump starter
3. 12V / 24V compatible starting with automatic detection
4. USB charging outlet and light



## PRODUCT OVERVIEW



- 
- 
- A. USB Output Port
  - B. Power Indicator Light
  - C. Master Button
  - D. 12V Indicator Light
  - E. 12V Forced Start Button
  - F. Charging Port
  - G. LED Flashlight
  - H. 24V Forced Start Button
  - J. 24V Indicator Light

## NOTICE

- 
- 
1. DO NOT use this product to start a car when the product is still hot or when there is not enough charge left in the product. More than 75% of remaining battery is needed to start a 24V vehicle and more than 50% is needed to start a 12V vehicle.
  2. Disconnect the battery clamp from the vehicle immediately after every starting attempt.
  3. DO NOT use the jump starter to start the car in high frequency. Allow at least 30 seconds of resting time before jump starting a car again.
  4. DO NOT charge the product immediately after use or while it is still hot. Make sure the temperature is between 0°C and 40°C when charging.
  5. Please charge the jump starter at least once a month to maintain battery life.
  6. DO NOT allow the metal teeth of the red clamp to touch the metal teeth of the black clamp.
  7. Please keep this product away from children.
  8. Please DO NOT disassemble this product.

- 
- 
9. Please store and charge the jump starter in a dry and well-ventilated place. Keep it away from corrosive, flammable and explosive materials.
  10. DO NOT expose this product to extreme environment conditions where the temperature and humidity is high.
  11. Never burn or incinerate this product because it may explode and generate toxic fumes and other potentially harmful chemicals.
  12. Never insert foreign objects into any input or output ports, because it may cause a short circuit which will damage the battery and even cause fire and personal injury.

## INSTRUCTION





### How to read the power indicator light:

1. Check the remaining power level. Press the master button to activate the lights.

There are 4 indicator lights in total to display the amount of battery power left. See the chart below to understand how the Number of lights and battery level corresponds.





No. of lights	1 Light	2 Lights	3 Lights	4 Lights
Battery	25%	50%	75%	100%

- 
- 
2. Check the current charging status. The indicator light will flash one by one when the jump starter is being charged. A solid light means a fully charged battery level. For example, when 2 lights are illuminated and a third is blinking, that means the unit is between 50%-75% charged. Once the third light stops blinking the unit is 75% charged. The 4 indicator lights will be off when the jump starter is fully charged.

**How to read the voltage indicator light:**

When the 12V or 24V indicator light is on, you could start the engine. When the 12V and/or 24V light(s) flash(es), you need to decide the voltage of your car battery manually and force start the engine. For more details, please refer to the following chart.



Voltage	Voltage Indicator Light	Output	Meaning
$V_b \leq 4.5V$	12V indicator light flashes	No	The voltage of 12V battery is too low
$4.5V \leq V_b \leq V$	12V indicator light is on	12V	You can start the engine now
$V \leq V_b \leq 13.5V$	12V indicator light is on	No	The 12V vehicle can start by itself
$13.5V \leq V_b \leq 14.5V$	12V and 24V indicator light flash alternately	No	Blind area-It cannot identify the voltage of vehicle's battery
$14.5V \leq V_b \leq 16V$	24V indicator light flashes	No	The voltage of 24V battery is too low
$16V \leq V_b \leq V*2$	24V indicator light is on	24V	You can start the engine now
$V*2 \leq V_b$	24V indicator light is on	No	The 24V vehicle can start by itself

V - the voltage of jump starter;  $V_b$  - the voltage of vehicle's battery

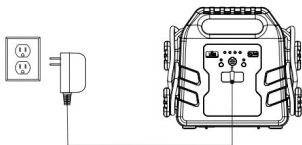

### **How to charge the jump starter:**

Both the power charger adapter and the car charger can charge the jump starter.

#### **Charge with Adapter:**

1. Insert the adapter into the household socket.
2. Insert the other end into the input port of the jump starter.

#### **Charge with the Car Charger:**

1. Plug the car charger into the 12V cigarette lighter on your vehicle.
2. Insert the other end into the input port of the jump starter.

#### **NOTE:**

DO NOT use the car charger with a 24V system. It can start a 24V system but cannot charge from one.

Failure to fully charge this product may be caused by prolonged storage. Battery capacity could be restored by fully discharging this product using the USB output port and then fully charging it. Repeat this discharge/charge cycle several times.

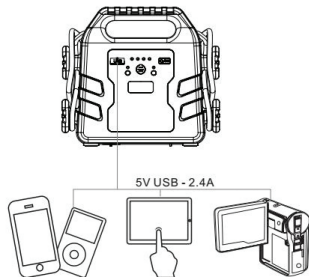

### **How to charge an electronic device:**

1. Use the USB cable to connect the jump starter and your device.

Turn on the jump starter by pressing the master button. Power indicator lights will show the battery level of the jump starter. The Power indicator lights will turn off by themselves after 5 seconds of inactivity. To check the indicator lights again, you need to press the master button.

### **How to use the LED flashlight:**

1. Double-click the master button to turn on the flashlight.
2. Single-click the button to change the flashlight mode in sequence: Strong > Strobe > SOS > Off.



### How to start a 12V/24V vehicle:

1. Check the remaining power. Make sure that the residual capacity of the jump starter is more than 75% when you are going to start a 24V vehicle, or more than 50% when you are going to start a 12V vehicle.
2. Connect the red clamp to the positive polarity(+) of the car battery and black clamp to the negative one(-). If 12V or 24V indicator light is solidly on, you can move on to step 3. If 12V and/or 24V light(s) flash(es), follow the guidance in the 'Manual Force Start' section.
3. Start the engine.
4. Remove the clamps from the car battery immediately after use.

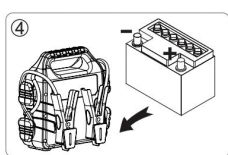
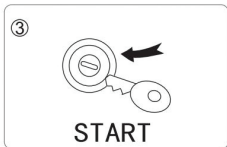
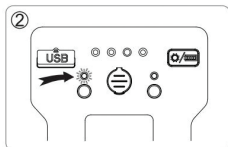
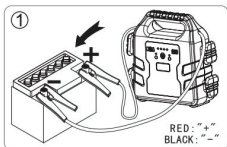

## Manual Force Start

**NOTE:** There is no short circuit protection under manual force start mode. Please make sure that the battery clamps are connected correctly.

1. Disconnect the clamps from the battery of your vehicle.
2. Confirm the voltage of your vehicle.
  - 1) If the voltage of your vehicle is 12V, you need to hold the FORCED START 12V button for 5 seconds. The 12V indicator light will be on. The jump starter would now supply 12V output.
  - 2) If the voltage of your vehicle is 24V, you need to hold the FORCED START 24V button for 5 seconds. The 24V indicator light will be on. The jump starter would now supply 24V output.

Move on to the next step within 45 seconds. Otherwise, the jump starter will cut off the output automatically.

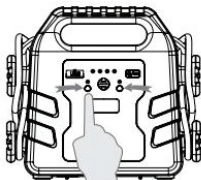

3. Connect the red clamp to the positive polarity (+) of the car battery and the black clamp to the negative one (-).
4. Start the engine.
5. Remove the clamps from the battery of your vehicle. The 12V and 24V indicator lights will keep flashing until the clamps are removed.

## INTELLIGENT PROTECTION

### 1. 12V/24V Short Circuit Protection

Short-circuit situations	Effects	Short circuit protection
Short-circuit the red and black clamps when the jump starter is off.	No Effects	Yes
Short-circuit the red and black clamps when the power indicator light is on.		
Short-circuit the red and black clamps when LED flashlight is on.		
Short-circuit the red and black clamps when you are using the USB port to charge electronic devices.		
Short-circuit the red and black clamps before holding FORCE START 12V/24V button. 12V/24V indicator lights flash alternatively.	After several seconds, the jump starter would turn off by itself.	
Short-circuit the red and black clamps after you have pressed the FORCE START 12V/24V button.	Warning!	No



### When would short circuit happen:

- When the teeth of the red clamp are connected to the teeth of the black clamp.
- When the red and black clamps are reversely connected to the polarities of the car battery.
- When the clamps are loosely connected to the car battery.

### 2. USB Output Short Circuit Protection

If the USB output port is shorted, all four power indicator lights will flash. **The jump starter will cut off the output and built-in buzzer will beep. After 3 seconds, buzzer will stop beeping and the jump starter will turn off by itself.** This may be caused by abnormal/damaged cables or charging devices. Identify where the problem comes from and rectify it before turning on the jump starter again.





### 3. USB Over-current Protection



If USB port supplies excessive current, all four power indicator lights will flash. **The jump starter will cut off the output and built-in buzzer will beep. After 3 seconds, buzzer will stop beeping and the jump starter will turn off by itself.** This may be caused by abnormal/damaged cables or charging devices. Identify where the problem comes from and rectify it before turning on the jump starter again.

### 4. Over Temperature Protection

- A. If the temperature of the jump starter's battery exceeds 55°C while it is being charged, over temperature protection will be activated. **The charging will stop, however, the power indicator light will be on, indicating the jump starter is being charged.**

- 
- 
- B. If the temperature of the jump starter's battery exceeds 55°C when it is being used, over temperature protection will be activated. **The red power indicator light will flash and the built-in buzzer will beep. 3 seconds later, buzzer would stop beeping.**

### **5. Built-in Software Under-Voltage and Over-Voltage Protection**

- A. Built-in software under-voltage protection: If the voltage of the battery cell is less than 3.1V, the output will be cut off. Please recharge the jump starter.
- B. Built-in software over-voltage protection: If the voltage of the battery cell exceeds 4.17V while charging, the charging will be stopped. Please disconnect the adapter from the jump starter.



### **6. Other protections/problems & corresponding indicator lights**



- A. Low voltage protection: Red power indicator light flashes.
- B. Reverse charging protection: 12V/24V indicator light flashes after starting a vehicle.
- C. Poor contact while charging: 12V/24V indicator lights flashes when the adapter is plugged into a socket. You may need to adjust the tip inside DC plug and re-connect the adapter with the socket.
- D. Reverse Polarity Protection: 12V/24V indicator lights flash alternatively. The built-in buzzer would keep beeping until the clamps are connected correctly.



## SPECIFICATIONS

Power Input:	15V @ 2A
Battery Type:	Lithium Polymer
Battery Capacity:	22,200mAh/88.8Wh
USB Output:	5V @ 2.4A
Start Current:	12V 500A / 24V 250A
Peak Current:	12V 1000A / 24V 500A
Operating Temperature:	0 to 60°C
Battery Lifespan:	> 1000 charge and discharge cycles
Dimensions:	269(W) x 241(H) x 129(D)mm
Weight:	2.7kg



## BOX CONTENTS



- 1 x Ultra High Capacity Jump Starter
- 1 x Mains Charger
- 1 x Car Charger
- 1 x Hang-Hook
- 1 x User Manual





Distributed by:  
TechBrands by Electus Distribution Pty. Ltd.  
320 Victoria Rd, Rydalmere  
NSW 2116 Australia  
Ph: 1300 738 555  
Int'l: +61 2 8832 3200  
Fax: 1300 738 500  
[www.techbrands.com](http://www.techbrands.com)  
Made in China

