

POWERTECH

MB3635

Dual-Channel Battery Charger



Instruction Manual

CONTENTS

Warnings & Safety Information	3
Before First Use	3
Box Contents	4
Product Diagram.....	4
Features	5
Charging Instructions	5
Slot/Mode.....	6
Reverse / Bad Cell / Short Circuit.....	6
LCD Reference	7
Specifications.....	7
Warranty Information.....	8

WARNINGS & SAFETY INFORMATION

WARNING: The manufacturer is not responsible for any potential injury from misuse

WARNING: Charger should not be left unattended while in use.

- This charger is intended for use with Ni-MH, NI-Cd, Li-ion and LiFePo4 rechargeable batteries only. Attempting to charge other types of batteries may cause personal injury and damage to the charger.
- Do not expose charger to rain or moisture. For indoor use only.
- Remove from power when not in use.
- Do not operate the charger if it has been subjected to shock or damage. Take it to a qualified serviceman for repair.
- Do not disassemble the charger. Incorrect reassembly may result in a risk of electric shock or fire.
- Unplug the charger from outlet before attempting any maintenance or cleaning. Use damp cloth to clean the surface, do not immerse in water.
- Before scrapping your charger, remove the batteries from the unit and ensure they are disposed of safely.
- This appliance can be used by children aged 8 years and above and persons with reduced physical, sensory or mental capabilities or lack of experience and knowledge if they have been given supervision or instruction concerning use of the appliance in a safe way and understand the hazards involved.
- Children shall not play with the appliance.
- Cleaning and user maintenance shall not be made by children without supervision.

BEFORE FIRST USE

Prior to using your product, please read all the safety and operating instructions thoroughly. Please ensure you follow the steps below before using the product. We recommend you keep the original packaging for storing the product when not in use.

Please pay close attention to the section entitled Warnings & Safety Information. Find a safe and convenient place to keep this instruction manual for future reference.

Unpack the product but keep all packaging materials until you have made sure your new product is undamaged and in good working order. Ensure you have all accessories listed in this manual.

BOX CONTENTS

- 1 x Battery Charger
- 1 X User Manual

PRODUCT DIAGRAM

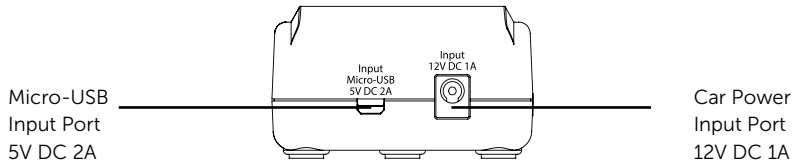
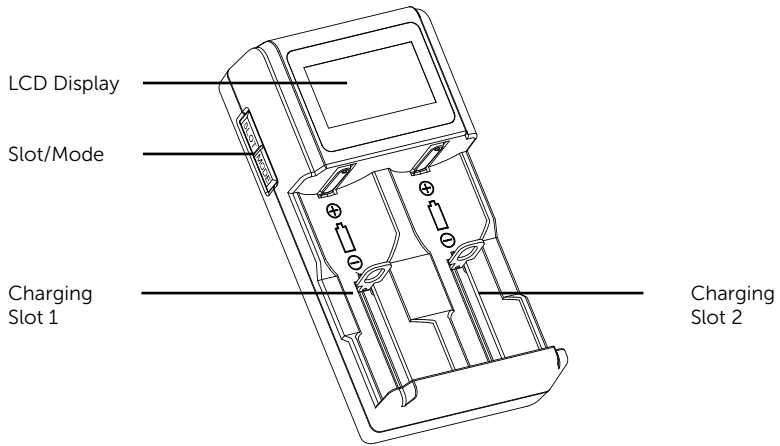

CHARGING INSTRUCTIONS

1. Connect the unit to a 5V DC 2A USB adaptor with the supplied Micro-USB cable or connect to a DC adaptor with 12V DC 1A. The LCD lights up automatically once the unit has been powered on.
2. Insert a rechargeable Ni-MH / Ni-Cd / Li-ion / LiFePo4 battery into the charging slots. Make sure the contact for polarity (+ / -) is matching to the signs in the charging slots. Reverse polarity or incorrectly inserting the batteries will result in charging failure, the "Error" icon will be shown on the LCD display and capacity gauge for the corresponding slot will flash rapidly. (See more in Reverse / Bad Cell / Short Circuit)
3. When charging begins, the "CHARGE" icon will be shown and the charging information will be shown corresponding to the slot with icon (▼) on the top of the charging indicator. Press the SLOT button to switch the display information to the next charging slot. Charging current is switchable for Li-ion / LiFePo4 to achieve faster charging by pressing the MODE button. (See more in SLOT / MODE)
4. When charging is completed, the "Finish" icon will be shown and (FUL) will be shown on the LCD display.

SLOT/MODE



When 2 batteries are charging at the same time, press SLOT to switch the display information (Battery Type, Charging Status, Current, Voltage, Time) for next charging slot.



Initial charging current is 500mA for all supported type batteries. Press MODE to switch between 500mA & 1000mA. (For Li-ion & LiFePo4 ONLY).



To charge LiFePo4, press SLOT & MODE at the same time.

WARNING: If the charger loses power, the charge setting will reset. If the charger auto-detects Li-ion but it is a LiFePo4, it may charge to the wrong voltage.

REVERSE / BAD CELL / SHORT CIRCUIT

Reverse the battery polarity, incorrectly inserting the battery, inserting alkaline battery or short circuit will result in charging failure, the "Error" icon will be shown on the LCD display and capacity gauge for the corresponding slot will flash rapidly. Should this occur, please reposition / replace / remove the battery from the slot.

LCD REFERENCE

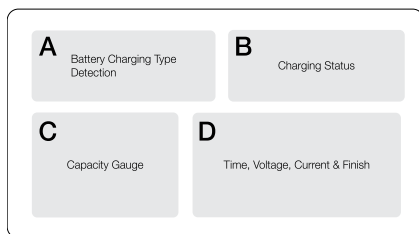

A Battery Charging Type Detection

NiMH / NiCd	It will be shown by Auto Detection
Li-ion	
LiFePo4	It will be shown ONLY when the SLOT & MODE buttons are pressed, please read SLOT / MODE before use.

B Charging Status

CHARGE	Charging starts
FINISH	Charging is finished
ERROR	Charging is failed (See more in Rverse / Bad Cell / Short Circuit)

C Capacity Gauge

▼	Indicates the charging slot selected (1or 2)	
Charging starts and the first block will be flashing	Charging is finished and all blocks are shown	Charging is failed and whole icon will be flashing

D Time, Voltage, Current & Finish

TIME	CHG.TIME 0:40	Shows the time spent for charging
VOLTAGE	1.42 V	Shows the current voltage
CURRENT	1000mA	Shows the charging current
FINISH	FUL	Charging finish (FULL)

Time, Voltage and Current will be shown alternatively by 5 second interval.

SPECIFICATIONS

Input	5V DC 2A (MICRO USB)
	12V DC 1A min. (DC POWER)
Output	NiMH / NiCd - 2 x 1.48V DC 500mA
	Li-ion - 2 x 4.2V DC 500mA or 1000mA
	LiFePo4 - 2 x 3.7V DC 500mA or 1000mA

WARRANTY INFORMATION

Our product is guaranteed to be free from manufacturing defects for a period of 12 Months.

If your product becomes defective during this period, Electus Distribution will repair, replace, or refund where a product is faulty; or not fit for intended purpose.

This warranty will not cover modified product; misuse or abuse of the product contrary to user instructions or packaging label; change of mind and normal wear and tear.

Our goods come with guarantees that cannot be excluded under the Australian Consumer Law. You are entitled to a replacement or refund for a major failure and for compensation for any other reasonably foreseeable loss or damage. You are also entitled to have the goods repaired or replaced if the goods fail to be of acceptable quality and failure does not amount to a major failure.

To claim warranty, please contact the place of purchase. You will need to show receipt or other proof of purchase. Additional information may be required to process your claim.

Any expenses relating to the return of your product to the store will normally have to be paid by you.

The benefits to the customer given by this warranty are in addition to other rights and remedies of the Australian Consumer Law in relation to the goods or services to which this warranty relates.

This warranty is provided by:

Electus Distribution

Address 46 Eastern Creek Drive, Eastern Creek NSW 2766

Ph. 1300 738 555