



**RFID Access Card Reader
LA-5351
User Manual**

DESCRIPTION AND FEATURES

1.1 Description

RFID Access Card Reader is fully waterproof standalone Proximity access control. It adopts the advanced MCU and large capacity Flash from Atmel, supporting up to 10000 cards. It is easy to add or delete card users by infrared remote keypad and master cards. It has the interfaces for external alarm, door contact, and exit button. They also have the functions of anti-passback.

1.2 Features

Feature	Description
Card Type	EM & HID card
IP Grade	IP65
Anti strong magnetism to open illegally	Field Effect Transistor control door
Large capacity	10,000 card users
Wiegand input/output	Wiegand 26. Can work as controller or reader
Anti passback	One door or two doors anti passback
Block enrollment	Can add 10,000 card users whose series number next to each other

INSTALLATION AND WIRE INSTRUCTION

2.1 Installation

- Drill holes on the wall or prepare the cassette
- Wire through the hole, and blanket the unused cable in case of short circuit
- Fix the back cover firmly on the cassette or the wall
- Attach the machine to the back cover

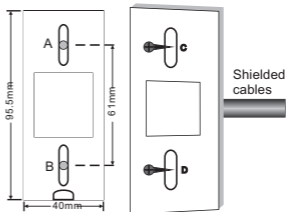

2.2 Features

Colour	Function	Description
Green	D0	Wiegand output, input signal wire D0
White	D1	Wiegand output, input signal wire D1
Grey	Alarm+	Connecting to the negative pole of the alarm equipment
Yellow	OPEN	To connect to one part of Exit Button
Brown	D_IN	Door Contact input
Red	12V	(+) 12Vdc Positive Regulated Power Input
Black	GND	(-) Negative Regulated Power Input
Blue	VSS	The negative pole of the controller, connect to the other part of Exit button and door contact
Purple	L-	Connect to the negative pole of the Lock
Orange	L+/Alarm+	Connect to the positive pole of the lock and alarm equipment

2.3 Connection Diagram

There have 2 types of electronic lock in market, Factory default setting are Type B electronic lock, The lock time is 5 seconds.

1. Type A electronic lock: Fail Secure lock (Unlock when power on), such as Electronic Controlling lock
2. Type B electronic lock: Fail safe lock (Unlock when power off), such as EM lock, Electronic Bolt Lock, etc

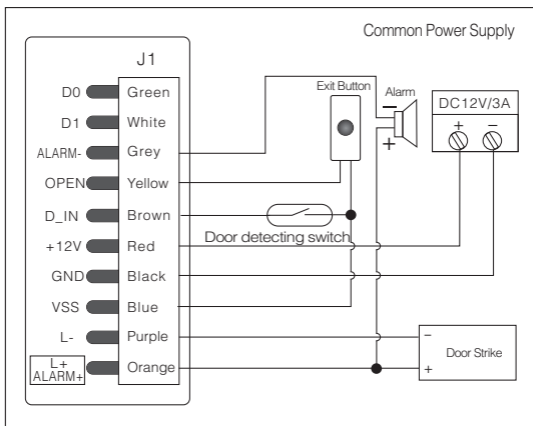

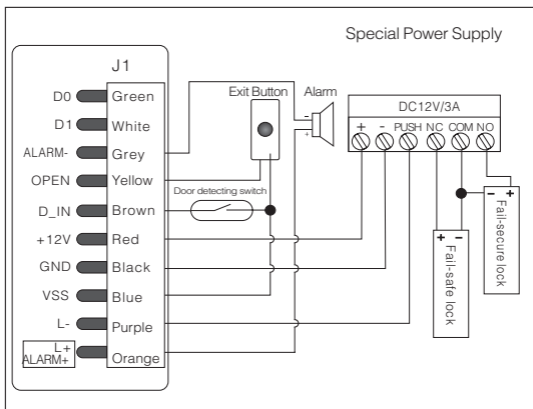

Note: Do not power on until all wiring has been completed

3. TO RESET TO FACTORY DEFAULT

Power off, use the supplied Contact Pin to short out the 2P socket on the main board, then power on, if successful, the beeper will beep twice, the LED shines in orange, remove the Short Pin, then read the Two Manager cards (Manager add card firstly, Manager delete card secondly), after that the LED turns in red, means reset to factory default setting successfully. Remarks: Reset to factory default setting, the users' information enrolled is still retained. When re-set to Factory setting, the two Manager cards must be re-enrolled.

4. USE MANAGER CARD

4.1 To add user by Manager Card

Read Manager add card
Read user card
Read Manager card
Quit add user mode

4.2 To delete user by Manager card

Read Manager delete card
Read user card
Read Manager card
Quit add user mode

Note: Users can be added or deleted continuously

5. MASTER OPERATION (BY REMOTE CONTROL)

Enter the programming mode

*888888# .888888 is the default factory master code

*Note: the following operation with "5" title, must enter into the programming mode. # means confirm, Last # means end current setting situation. * means quit*

5.1 Change the master code

Code must be 6-8 digits numbers.

To change the master code again, the master user must be logged in and key '0' 'New code' # 'New code' #.

5.2 Add user

5.2.1 To read card continuously - 1 read user card #

5.2.2 To input card number continuously - 1 8digits card number #

5.2.3 To add series card number -

8 8digits card number # card quantity #

Card quantity is between 1-9999 It takes 45minutes to add 9999 cards.

During the time, the green light blinks

5.3 Delete user

5.3.1 Delete card by reading continuously

2 read card #

5.3.2 Delete card by inputing card number continuously

2 8digits card number #

5.3.3 Delete all

2 0000#

This option will delete all users but manager cards. Be careful when using.

5.4 Anti-passback setting

5.4.1 Anti-passback disabled (Factory default)

3 0 #

5.4.2 Anti-passback master mode

3 1 #

5.4.3 Anti-passback Auxiliary mode

3 2 #

Note: The detailed wiring diagram and illustration, please refer to the "Advanced application"

5.5 Lock power setting

5.5.1 Fail secure (Unlocked when power on) 4 0-99 # is to set the door relay time.0s=50ms

5.5.2 Fail safe (Unlocked when power is off) 5 1-99 #

5.6 Door open detection

5.6.1 To disable door open detection 6 0 #

5.6.2 To enable door open detection 6 1 #

When this function is enabled, there are two situations

1. If the door is opened normally, but not closed after 1 minute, the inside buzzer will beep automatically to remind people to close the door. Close the door or read user card can stop the beep
2. Push the door after it is opened in 120minutes by legal way; or the door is forced open, the external alarm system and Buzzer built-in controller will give alarm sound

5.7 Secure mode and LED light setting

5.7.1 Secure mode setting

5.7.1.1 Normal mode:

7 0 #

No lockout or alarm, and it is factory default setting.

5.7.1.2 Lockout mode:

7 1 #

The machine will lockout for 10 minutes if we swipe 10 times invalid card in 10 minutes.

5.7.1.3 Alarm mode:

7 2 #

External alarm system and Buzzer built-in controller will give alarm sound in the same time when we swipe 10 times invalid card in 10 minutes.

5.7.2 LED light setting

5.7.2.1 RED LED ON(factory default setting):

7 3 #

5.7.2.2 RED LED OFF:

7 4 #

5.8 Time of alarm setting

5.8 0~3 #

Alarm time: 0~3 minutes, default setting is 1minute

6. OPERATION OF OPENING THE DOOR

Open the door by swiping valid card.

7. DISALERT ALAM OPERATION

Three ways: swiping user card, manager card, input manager's PIN.

8. SOUND AND LED LIGHT INDICATION

Operation Status	Colour of LED	Sound of Buzzer
Stand by Status	Slow RED flash	
Press key of remote control		Bee-eep
Enter into programming	RED on	Bee-eep
Enter into setting	ORANGE on	Beep
Error		Beep, Beep, Beep
Open the door	GREEN	Bee-eep
Alarm	Quick RED flash	Alarm Sound

9. TECHNICAL PARAMETERS

Working Voltage	DC12V±10%
Stand by Current	<15mA
Swiping Distance	3-8cm
Operating Temperature	-40°C
Operating Humidity	0-95% RH
Max Current of lock output load	3A
Max Current of alarm output load	3A
Manager card (EM card)	One add card, one delete card
Dimension	103 x 48 x 23mm

10. PACKING LIST

Name	Quantity	Remark
Waterproof Reader	1	
Infrared Remote Control	1	
Manager Add Card	1	
Manager Delete Card	1	
Short Pin	1	Used for factory default setting
User Manual	1	
Self Tapping Screws	4/2	3.5(Dia.) x 27mm

Please ensure that all the above contents are correct. If any are missing, Please notify the supplier.

11. ADVANCED APPLICATION

11.1 Operating as a Wiegand output reader.

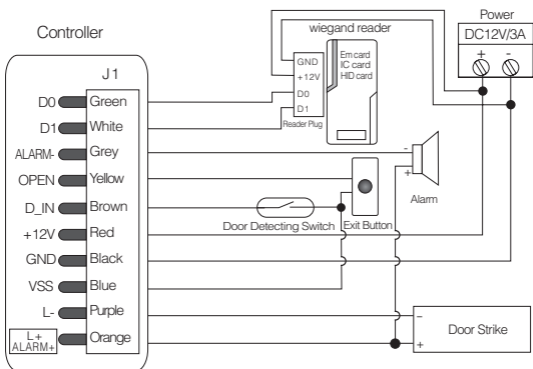

Figure 4

Diagram of output reader and anti-pass back for single door.

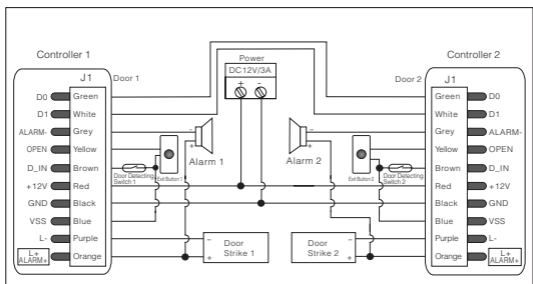

Figure 5

11.2 Anti-passback function for single door (Set as function 5. 4.2)

The connection diagram is as figure 4. Install one Wiegand reader (without user information as reader) outside the door, connecting to one Controller inside the door, which acts as the Anti-passback Master unit of the two devices, they build up an Anti-passback system for single door.

The operation function is as below:

11.3 Set the needed function and enroll the User Cards on the inside Anti-passback Master unit.

11.4 With the valid user card, the user can only enter the door from the outside reader, and exit from the inside Controller. On the other hand, without entering record from the reader, the user can't exit from the controller inside, also, the user can't enter in twice without the first exit record , and vice versa.

11.5 Anti-passback function for 2 doors (Set as function 5.4.2)

The connection diagram is as Figure 5. Door 1 with one Card Reader, and Door 2 with one Card Reader, set one Card Reader on Door 1 as the Anti-passback Auxiliary unit, and set the other Card Reader on Door 2 as the Anti-passback Master unit. They build up a two doors Anti-passback system, which is normally used for parking lot.....etc.

The operation function is as below:

11.6 Set the needed function and enroll the User Cards from Anti-passback Master unit on Door 2.

11.7 With the valid user card, the user can only enter in from Door 1, and exit from Door 2. On the other hand, without entering record from the Auxiliary unit, the user can't exit from the Master unit or Auxiliary unit , also, the user can't enter in twice without the first exit record , and vice versa

Colour	Function	Description
Green	D0	Wiegand output, input signal wire D0
White	D1	Wiegand output, input signal wire D1
Grey	Alarm+	Connecting to the negative pole of the alarm equipment
Yellow	OPEN	To connect to one part of Exit Button
Brown	D_IN	Door Contact input
Red	12V	(+) 12Vdc Positive Regulated Power Input
Black	GND	(-) Negative Regulated Power Input
Blue	VSS	The negative pole of the controller, connect to the other part of Exit button and door contact
Purple	L-	Connect to the negative pole of the Lock
Orange	L+/Alarm+	Connect to the positive pole of the lock and alarm equipment

Distributed by:
TechBrands by Electus Distribution Pty. Ltd.
320 Victoria Rd, Rydalmere
NSW 2116 Australia
Ph: 1300 738 555
Int'l: +61 2 8832 3200
Fax: 1300 738 500
www.techbrands.com
Made in China