

Tobbie The Robot

• Your adorable smart friend •



Assembly & Instruction
Manual

CONTENTS

Product Introduction	1
Tools You May Need	1
Mechanical Parts List	1
Plastic Parts	3
Tip:Cut Off The Burrs Before Assembly	3
Body Module Assembly	4
Head Module Assembly	10
Feet & Arms Module Assembly	24
How To Replace Batteries	26
How To Play	27
Warning	29
Trouble Shooting	30



Tobbie The Robot

Product Introduction

Tobbie is an intelligent six legs robot which provides great interaction with children. Tobbie has two programmed modes to follow or avoid objects. In "Follow Me" mode, Tobbie follows the object which ever approaches it, and makes it feels like an obedient pet. Possessing IR auto detect, Tobbie can avoid obstacle in the "Explore" mode and find a new route to keep moving. The little robot offers wonderful sound and light effect which develops its own emotions and gestures, just like a living pet.

Try to challenge Tobbie and figure out what it can do. Create a maze for it or allow it to follow you. Most of all, do not treat it as a normal robot, but an adorable smart friend.

Tools You May Need

Diagonal Cutter



Screwdriver









Battery(AAA) x 4



Alkaline batteries are recommended

Mechanical Parts List

! Product contains functional edges and sharp points.



P1	Pinion Gear(White)	QTY	P2	Gear 32/10T(Gray)	QTY	P3	Gear 32T(Blue)	QTY
		2			1			1
P4	Gear 36/14T(Green)	QTY	P5	Gear 36/14T(White)	QTY	P6	Gear 36T(Orange)	QTY
		1			2			1

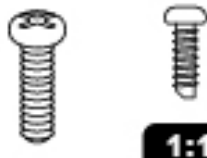

P7 Gear 40/10T(Pink)	
	QTY 1

P8 Gear 10T(Orange)	
	QTY 2

P9 Tapping Screw	
	QTY 20
1:1	

P10 Tapping Screw	
	QTY 4
1:1	

P11 Shaft (Short)	
	QTY 3
 (1:1)	

P12 Shaft (Long)	
	QTY 2
 (1:1)	

P13 Motor With Connector	
	QTY 1

P14 Motor With Connector	
	QTY 1

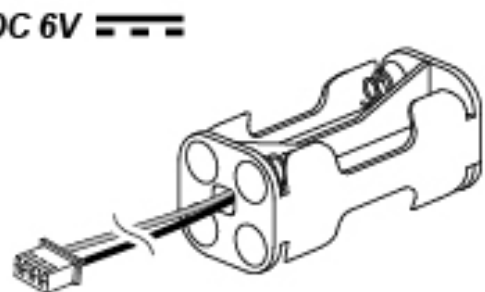
P15 Battery Holder With Connector	
	QTY 1

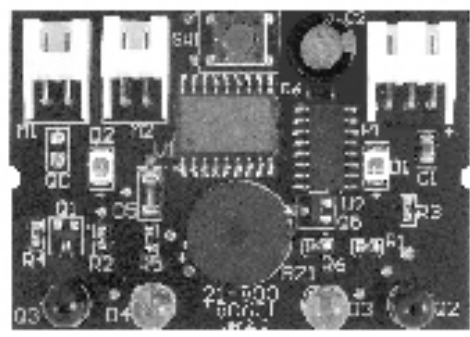
P16 PC Board	
	QTY 1

P17 Sticker	
	QTY 1

Plastic Parts

! Cut the plastic parts when they are required. Do not cut them in advance.

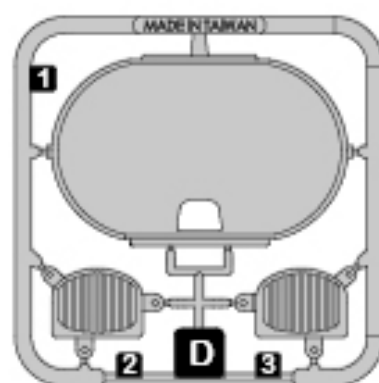
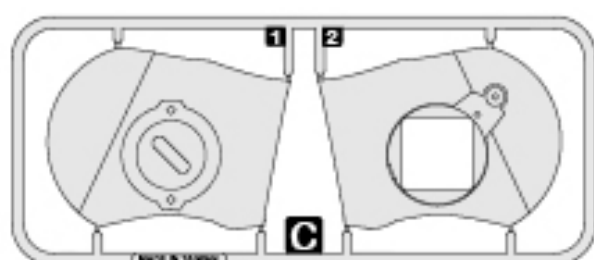
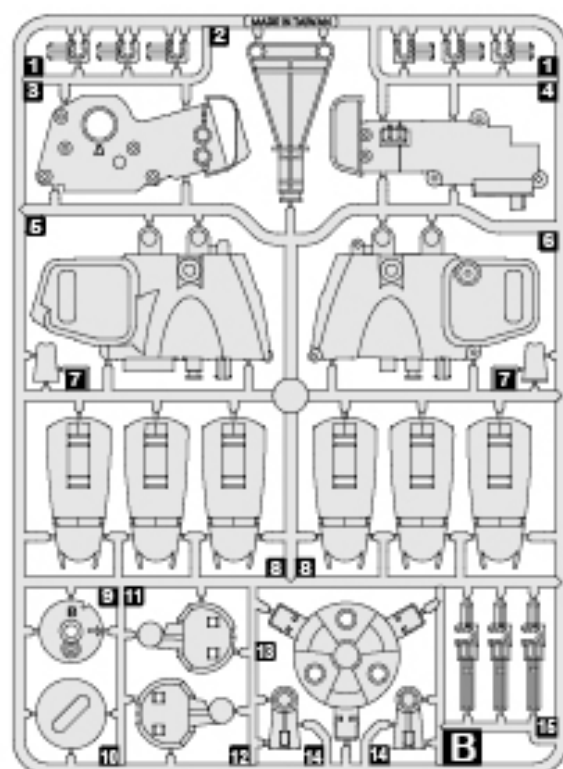
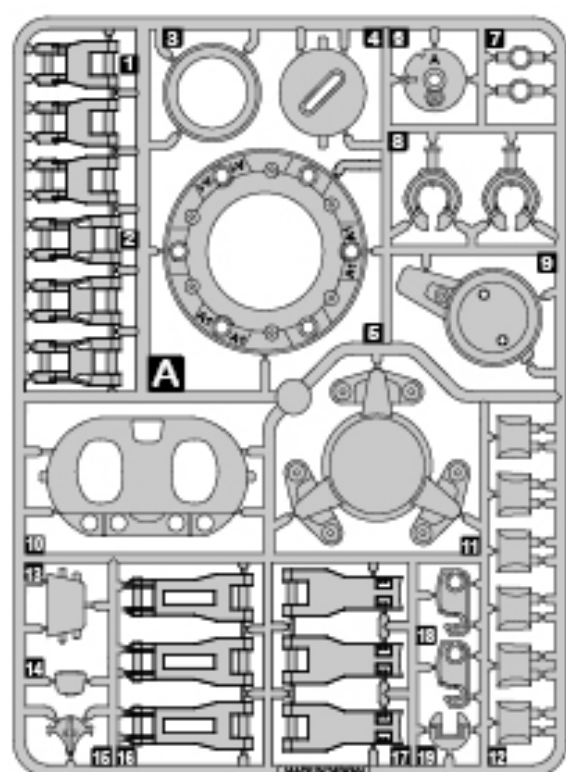

⚠ Tip: cut off the burrs before assembly

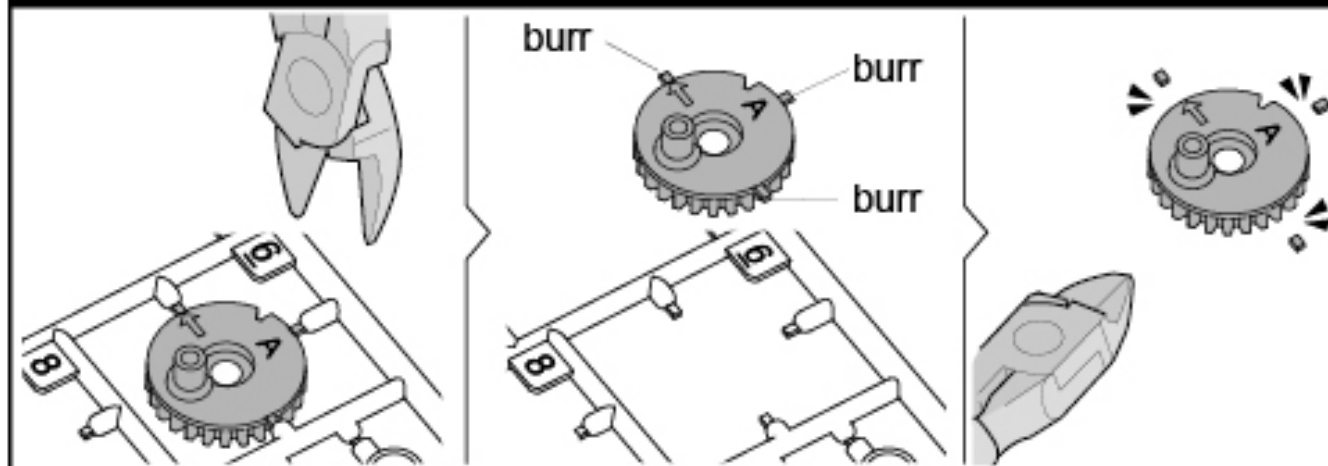

Body Module Assembly

1

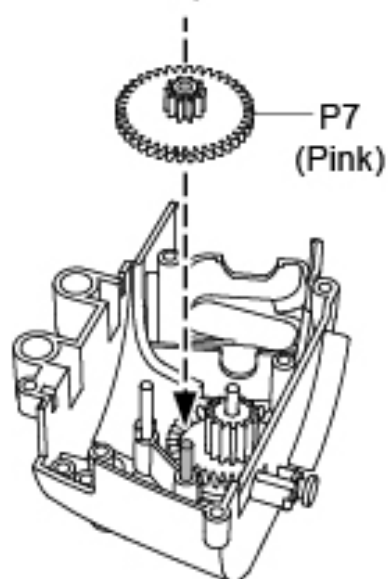
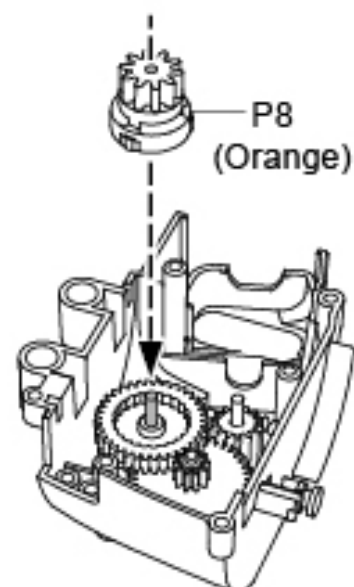
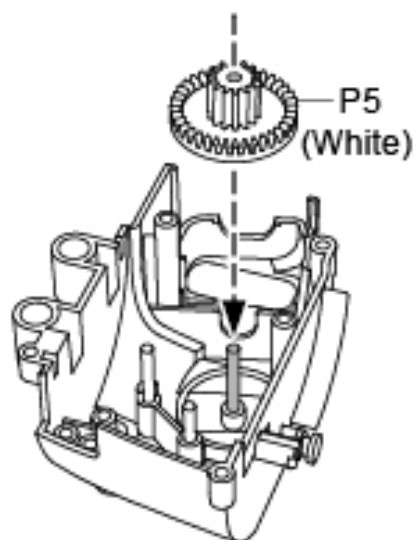
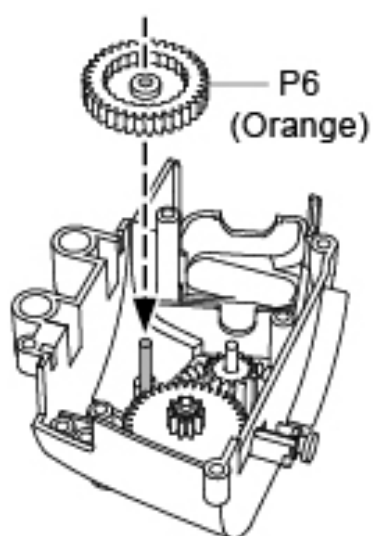
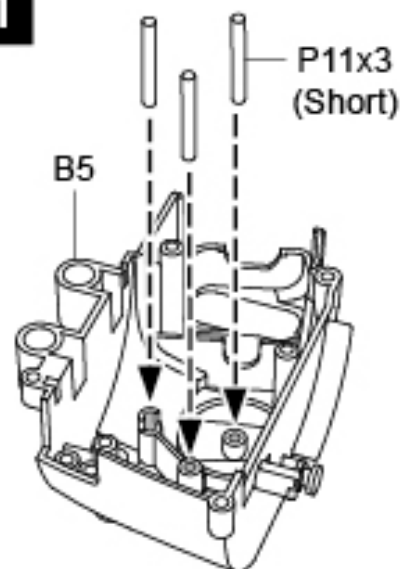

2

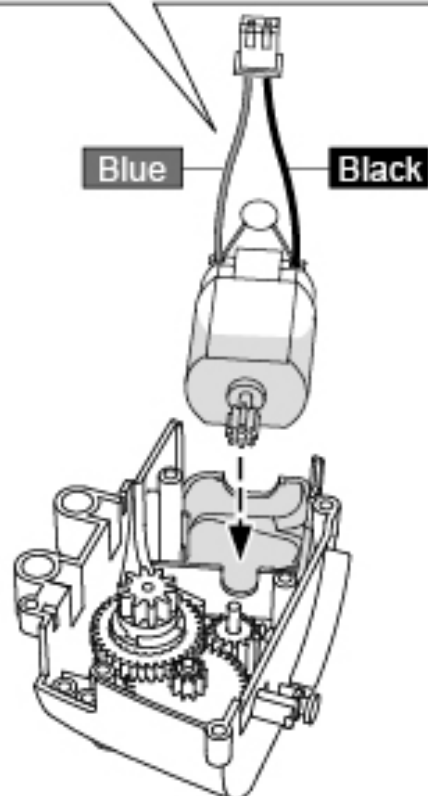
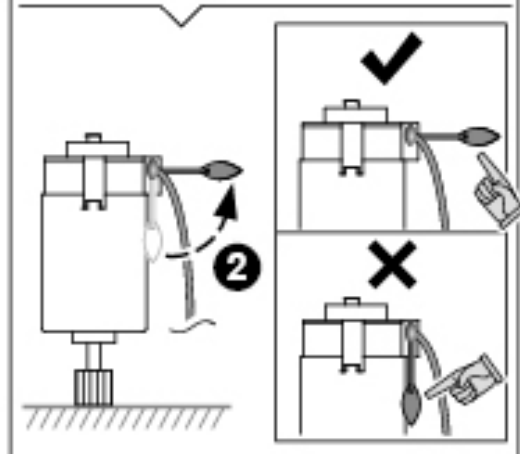
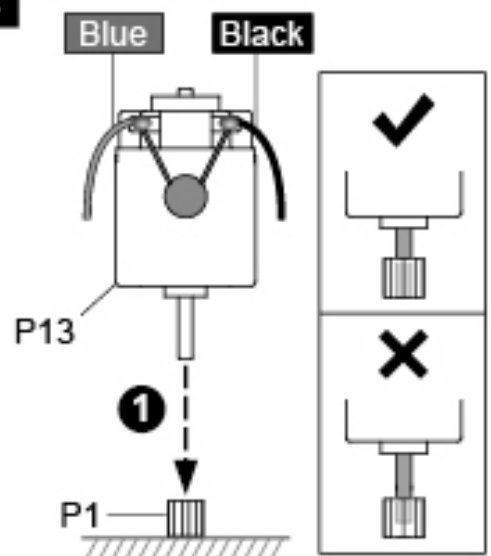

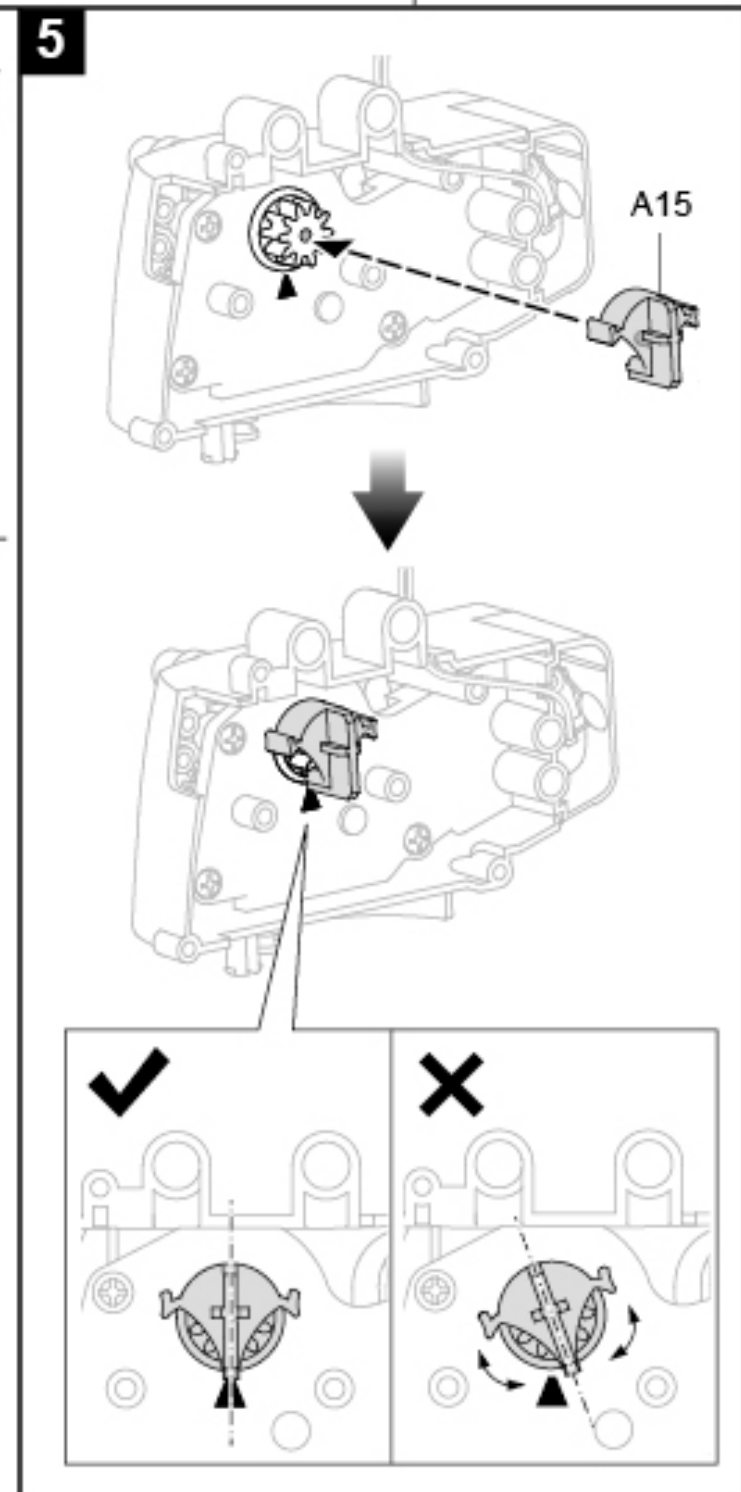
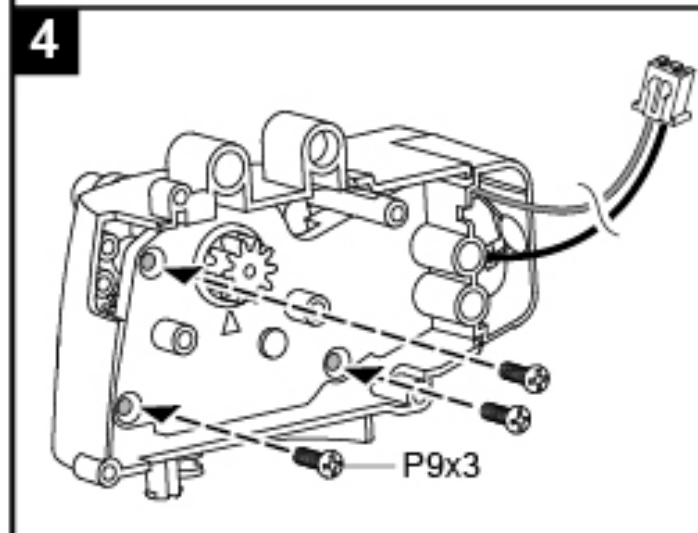
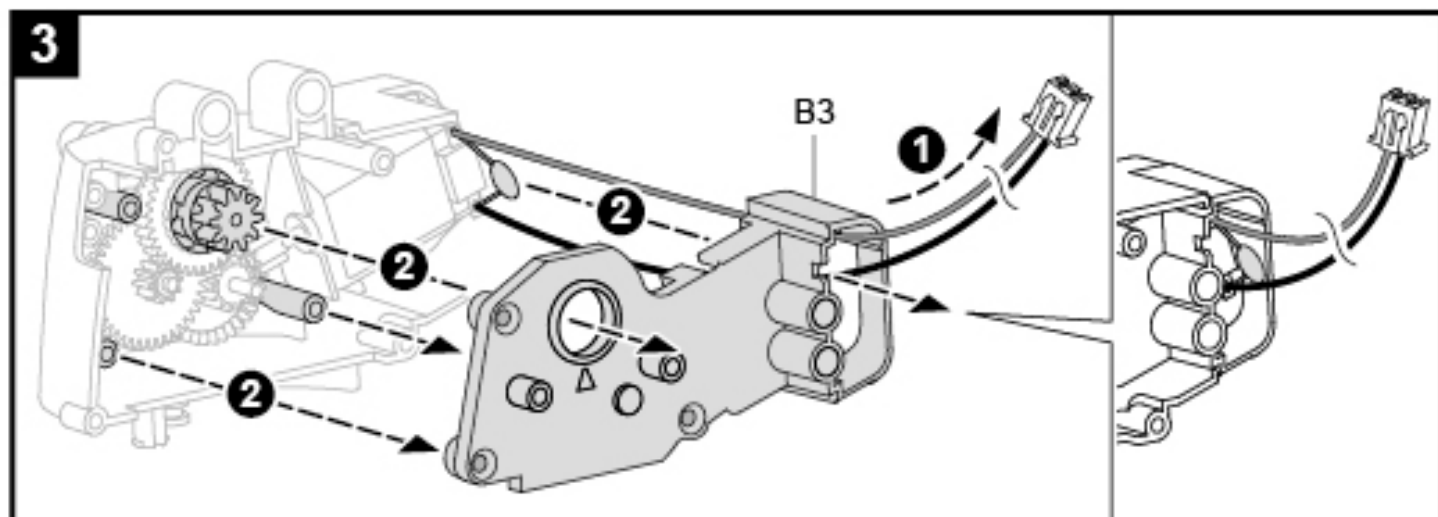

6

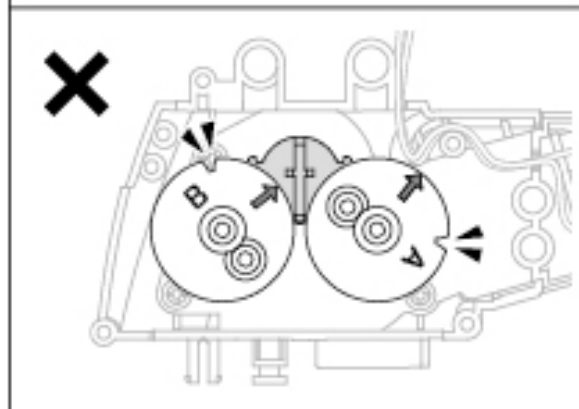
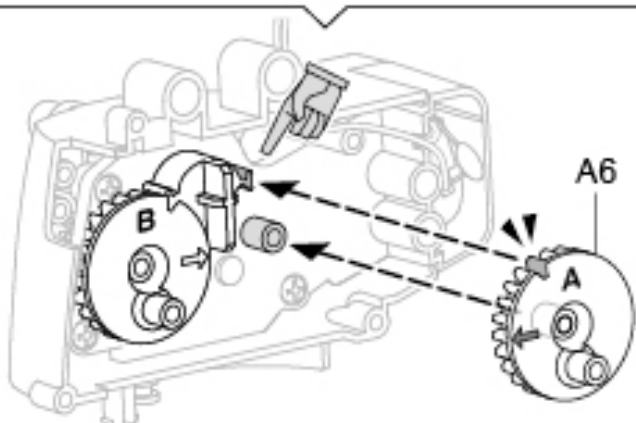
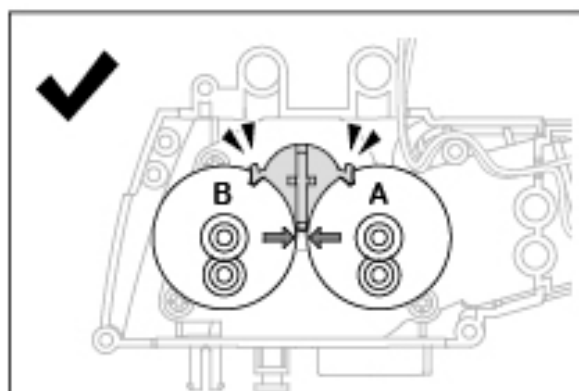
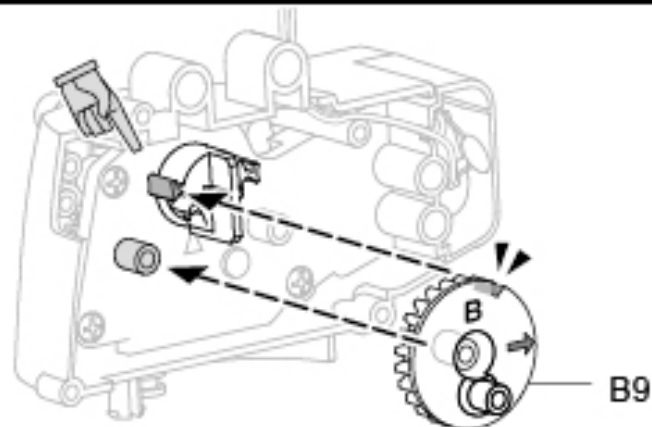

7

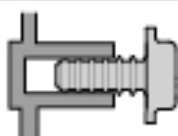
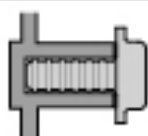
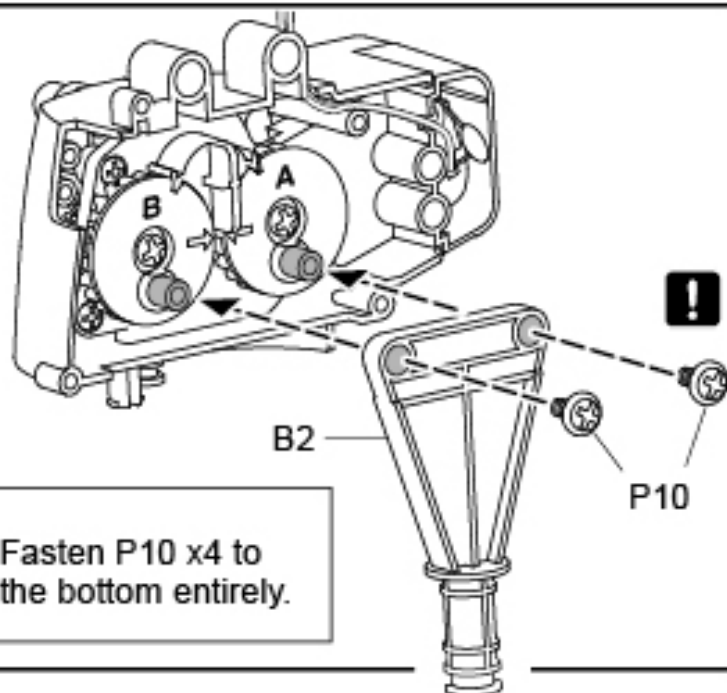
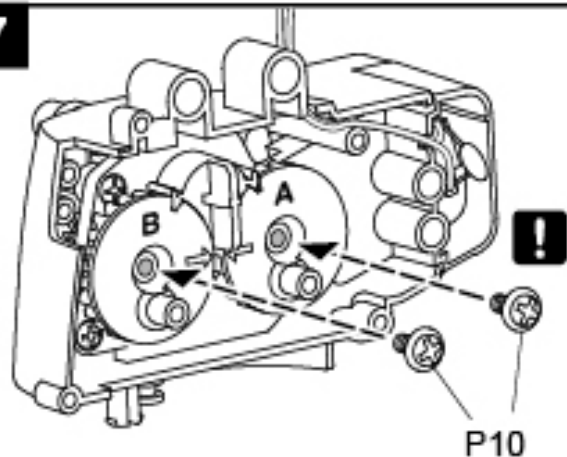

Fasten P10 x4 to the bottom entirely.

8

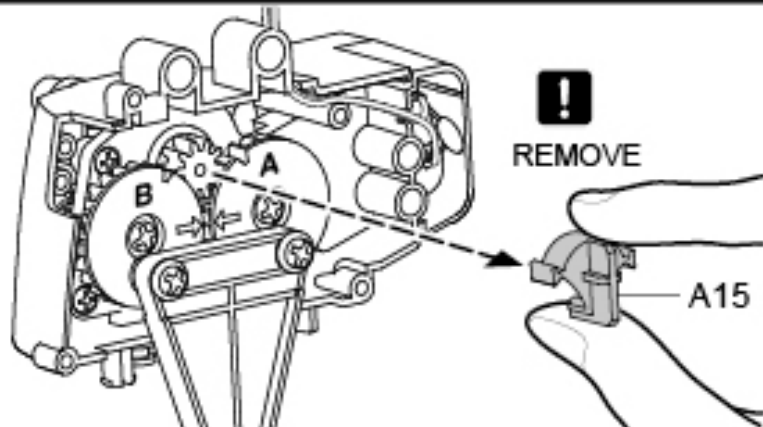

Important : Remove assistance tool-A15 after above steps are finished.

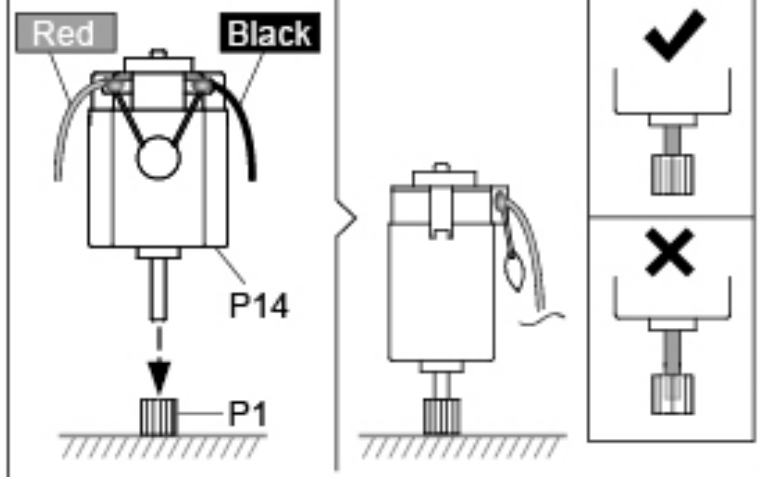
9

B6

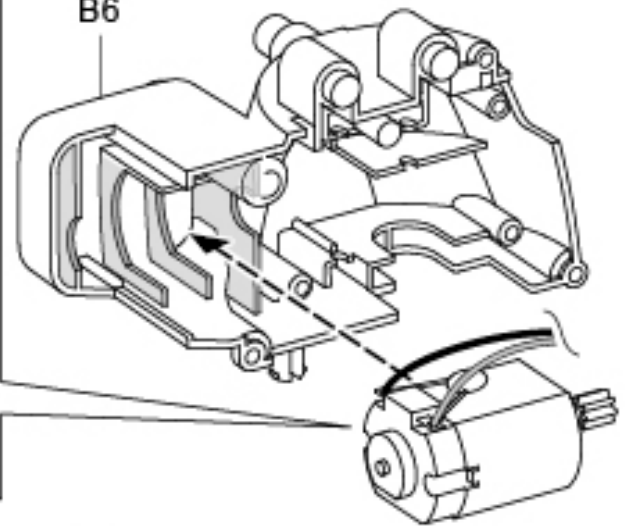
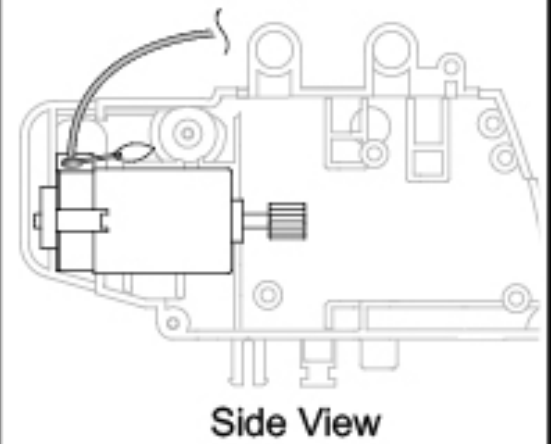
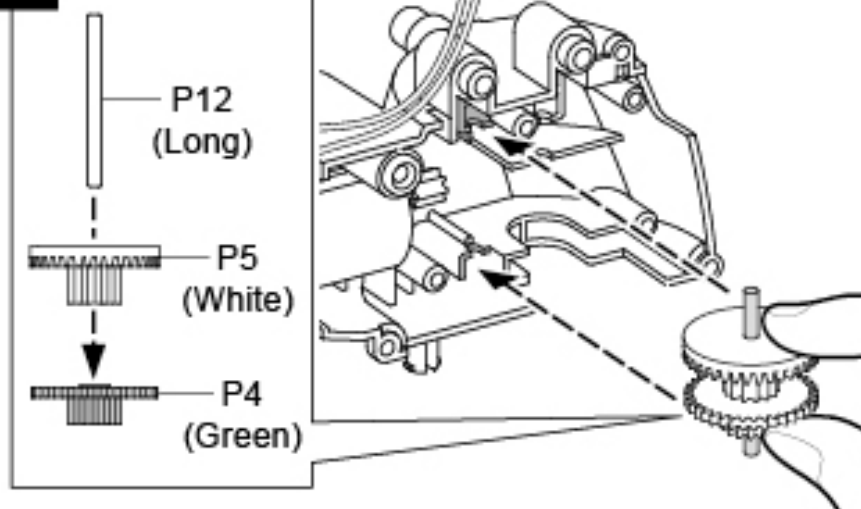
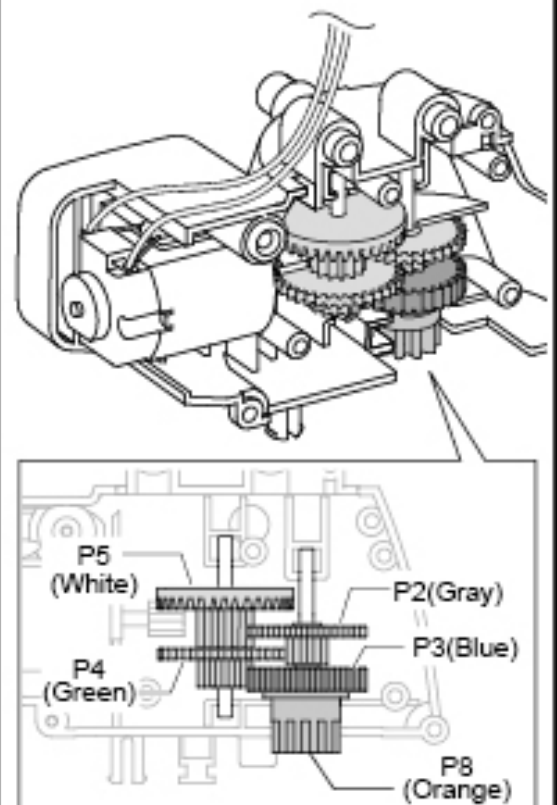
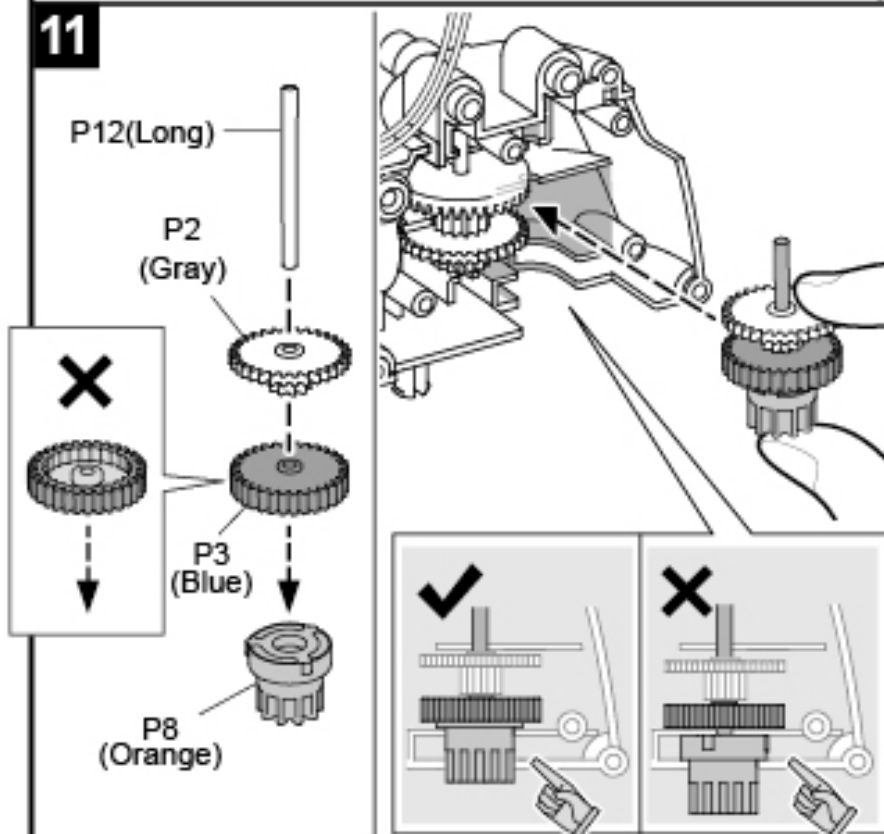
**10****11**

12

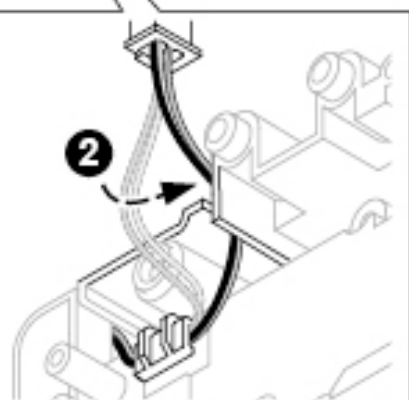
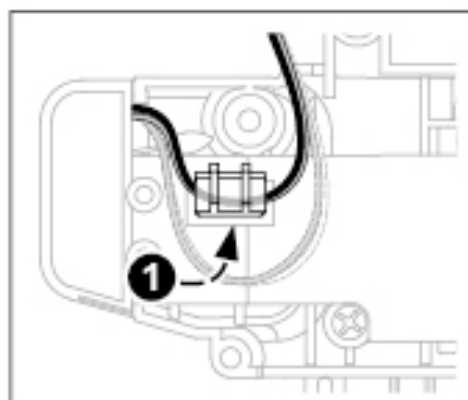
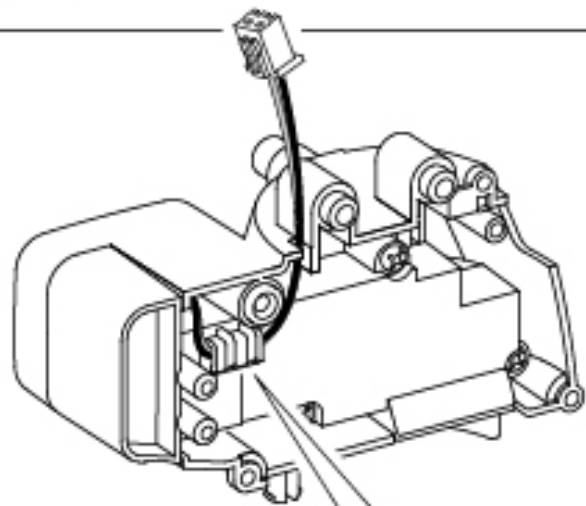
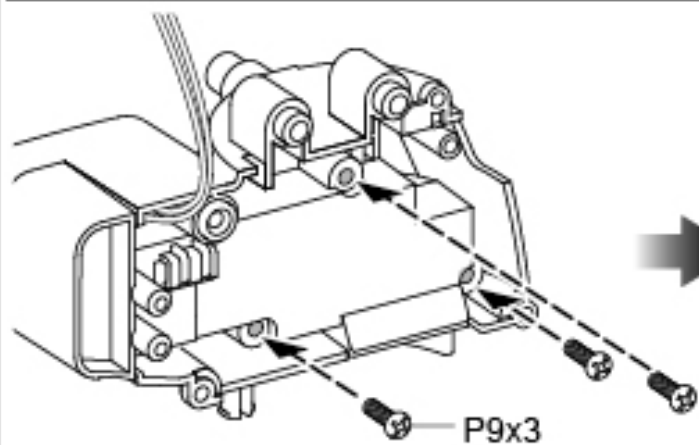
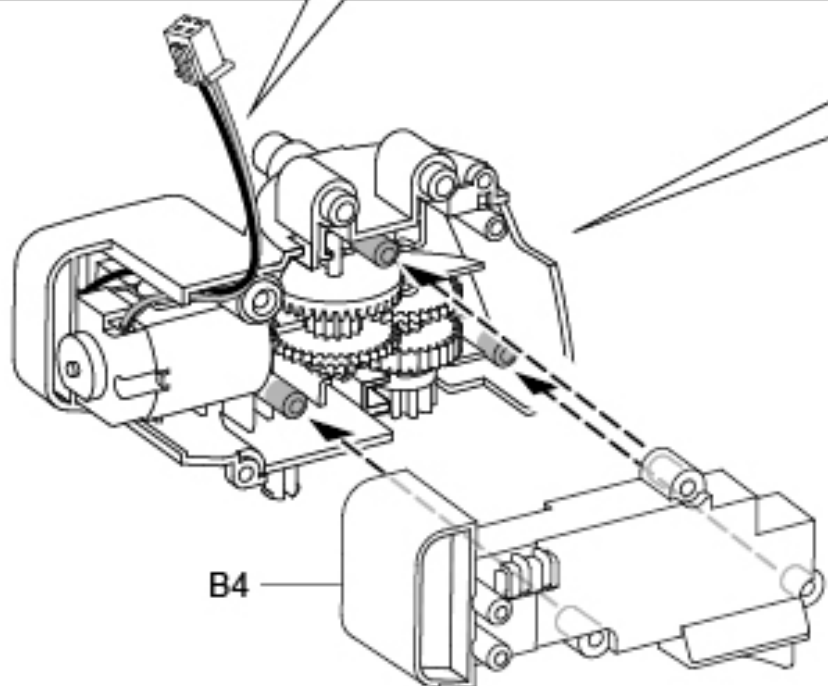
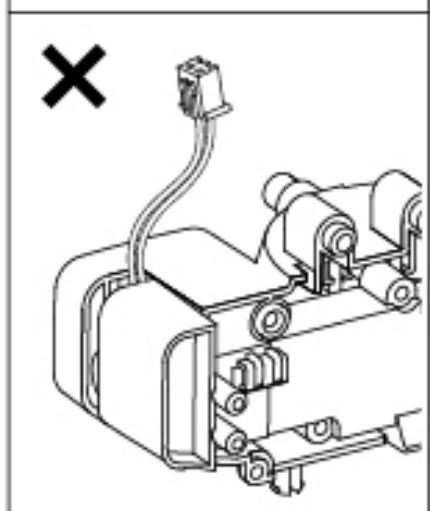
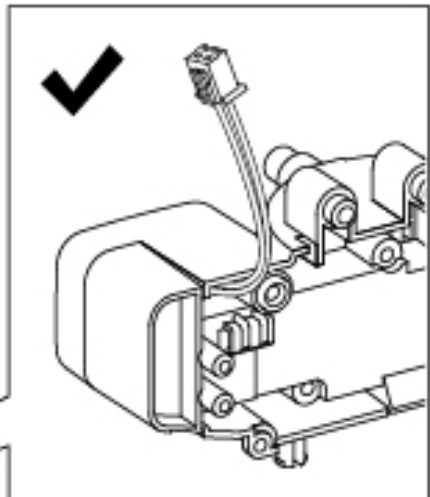
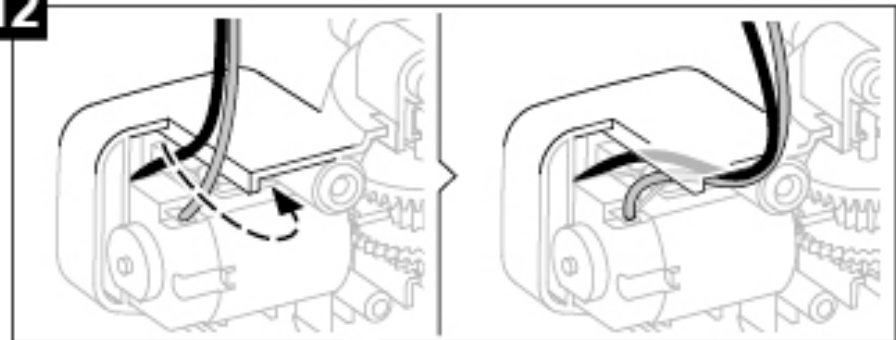

13

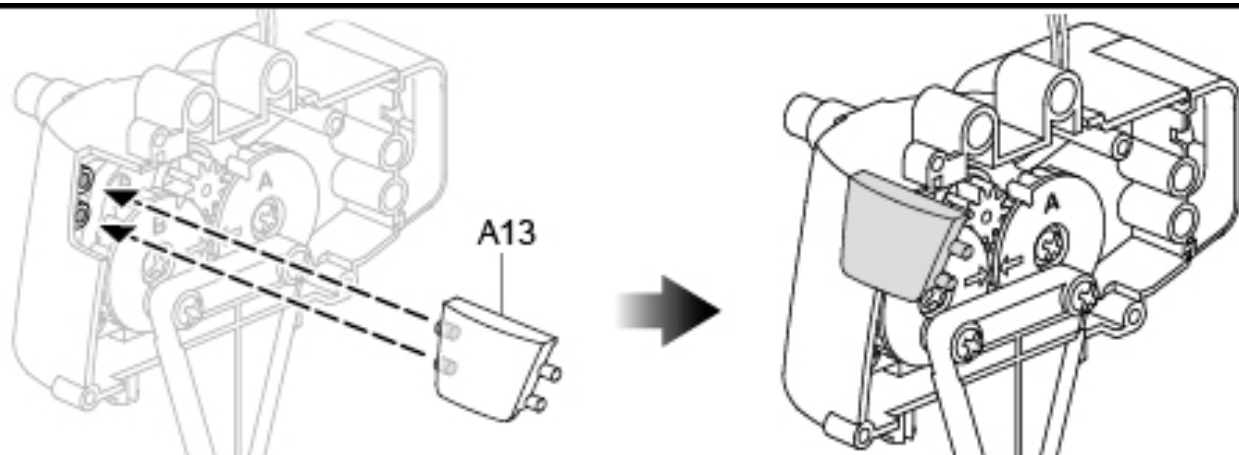

14

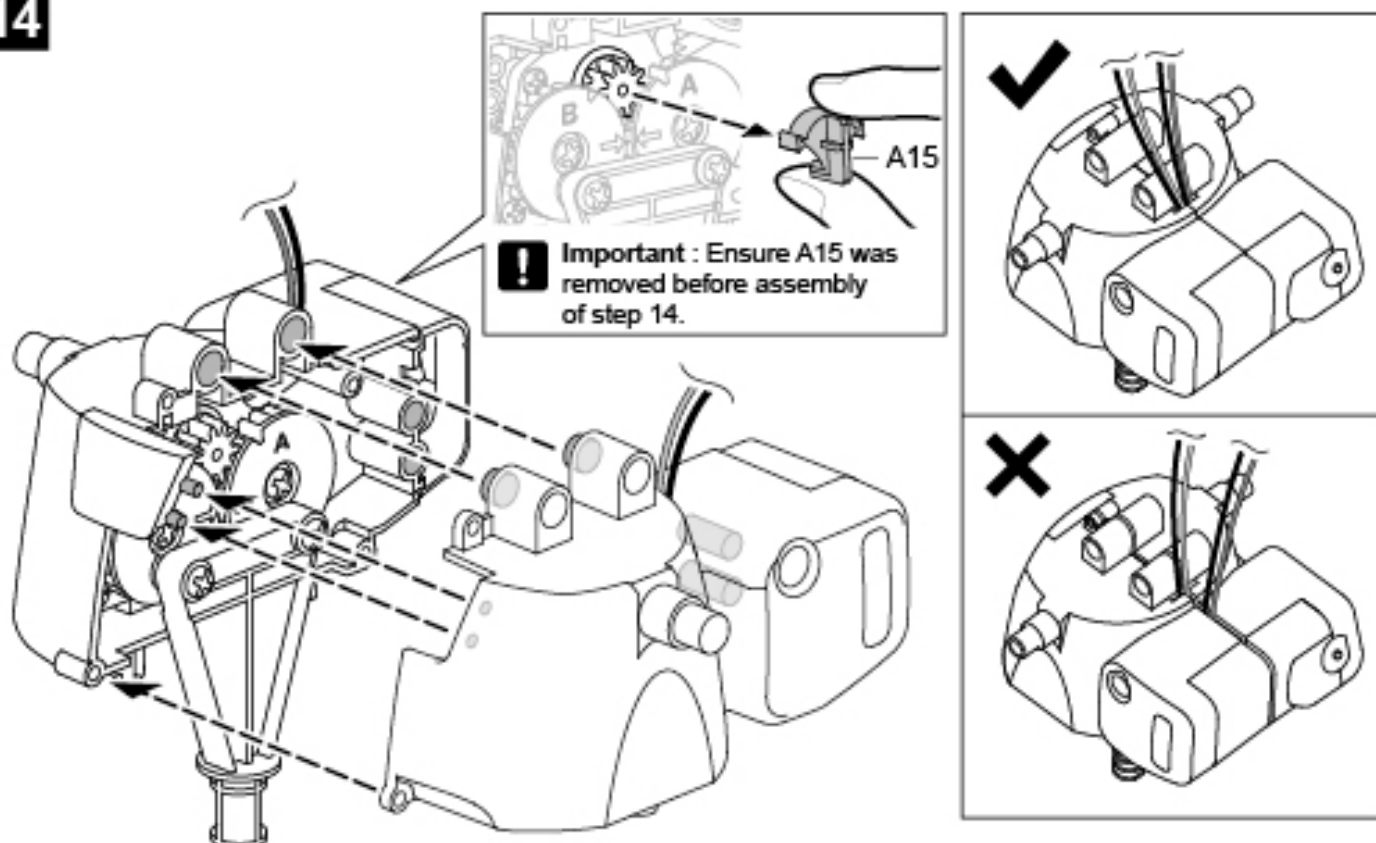

15

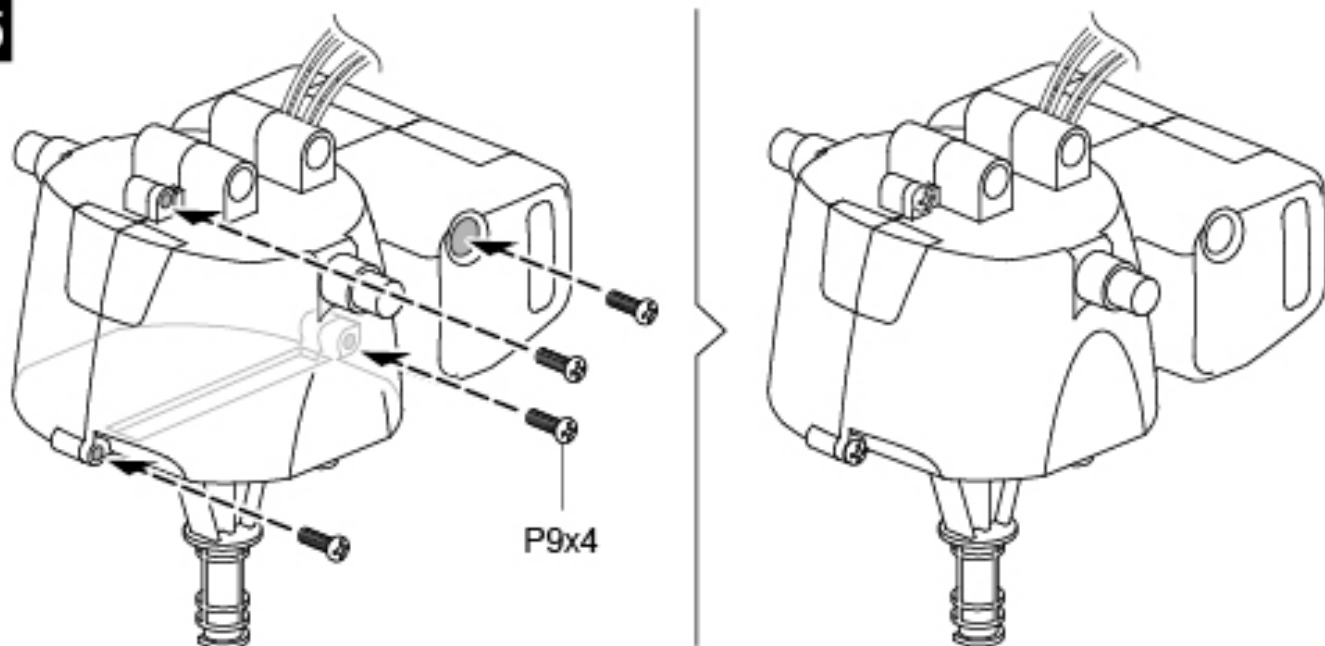

Head Module Assembly

1

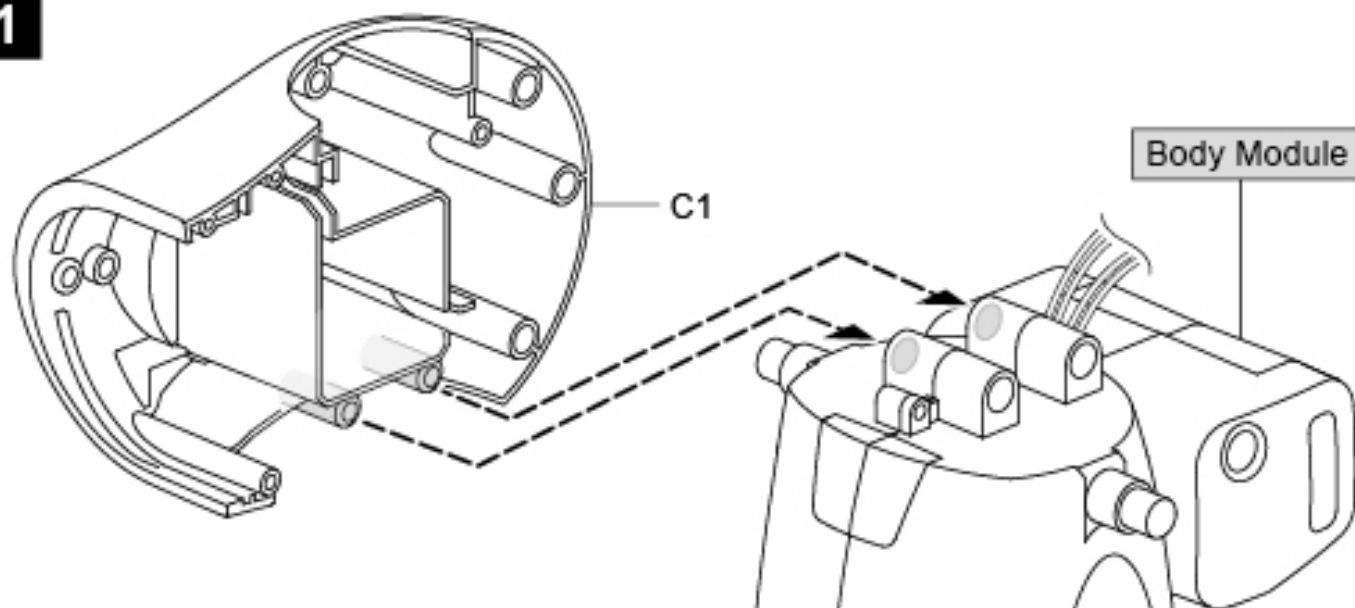

2

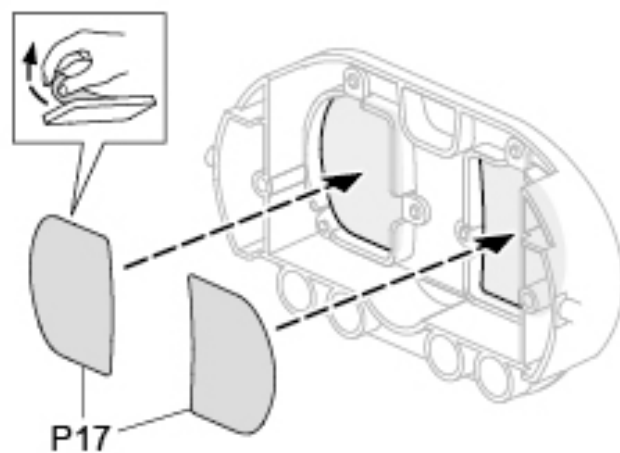
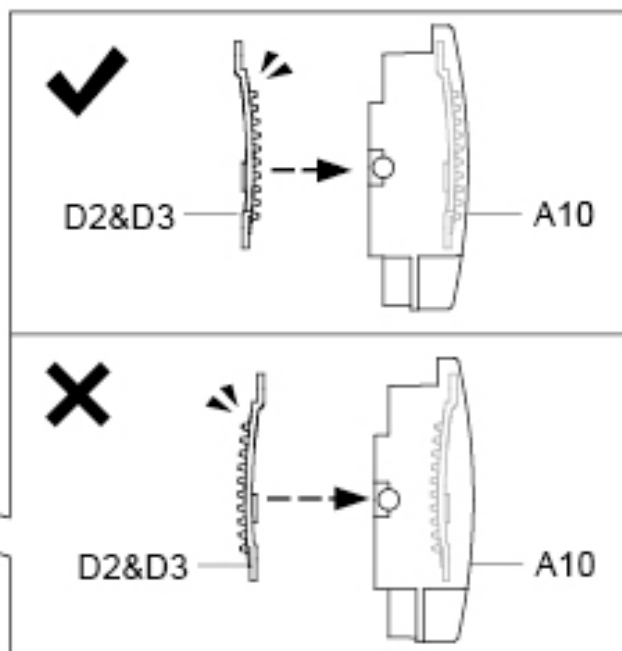
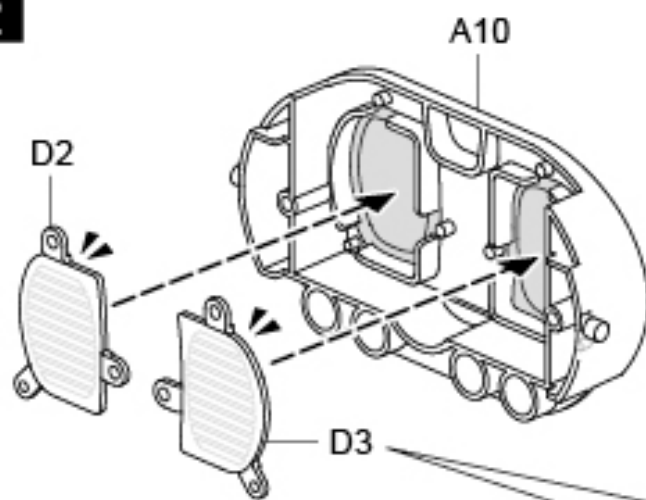

*P17 is on a white sticker sheet

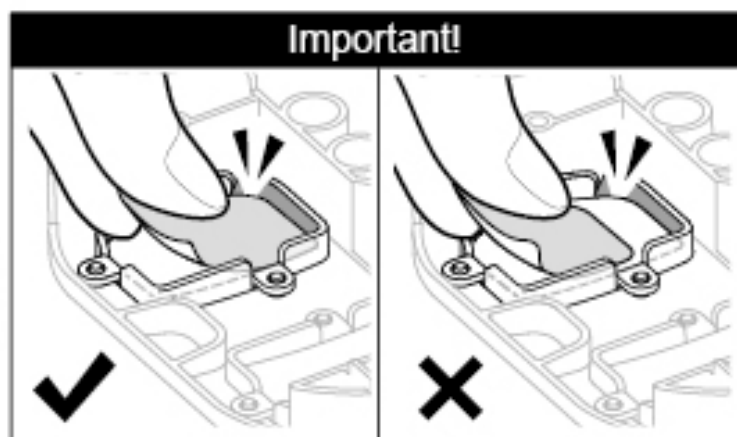

Post P17 against corner of indent in A10

3

A14

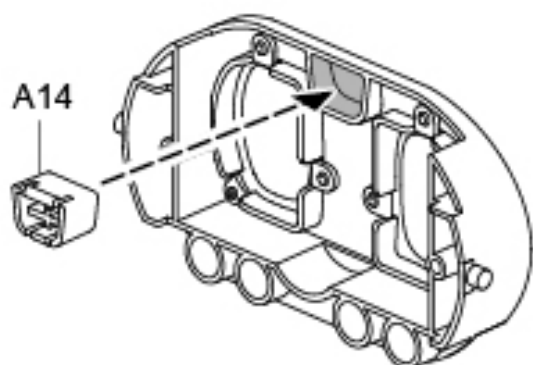

P16

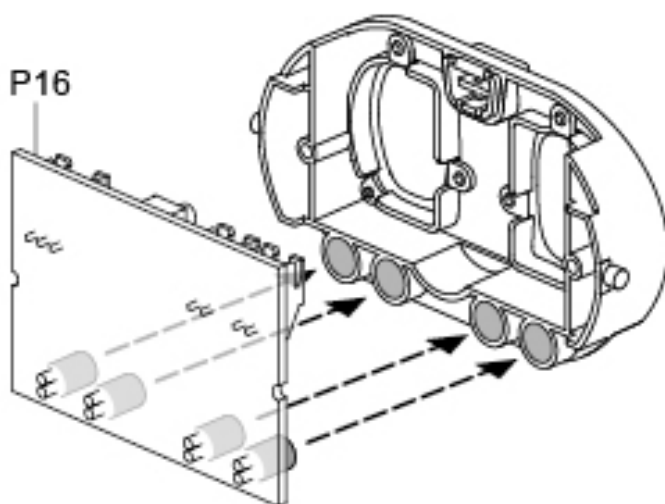

4

P16

P9x2

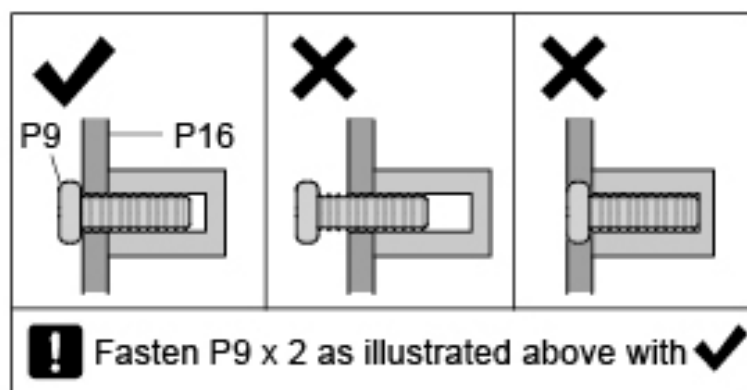
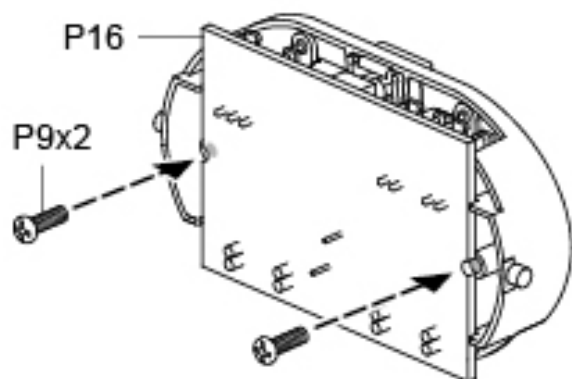

D1

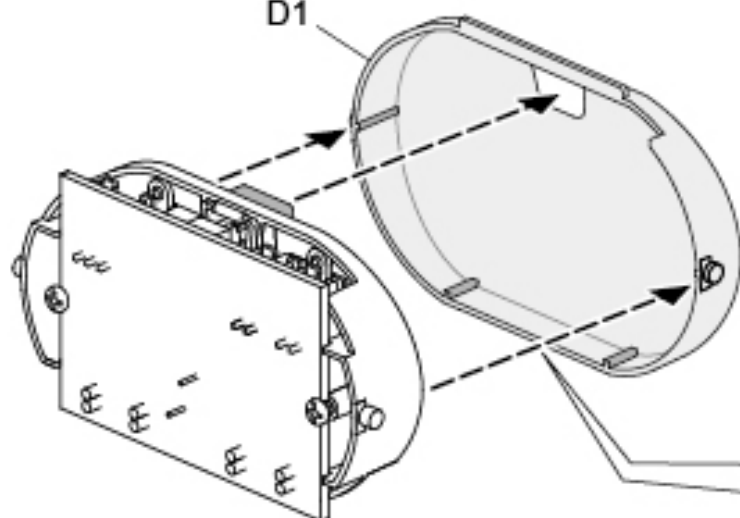

! Cut off the burrs before assembly.

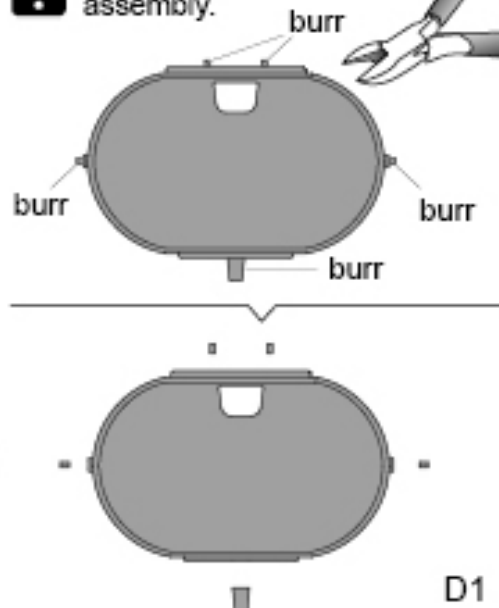

5

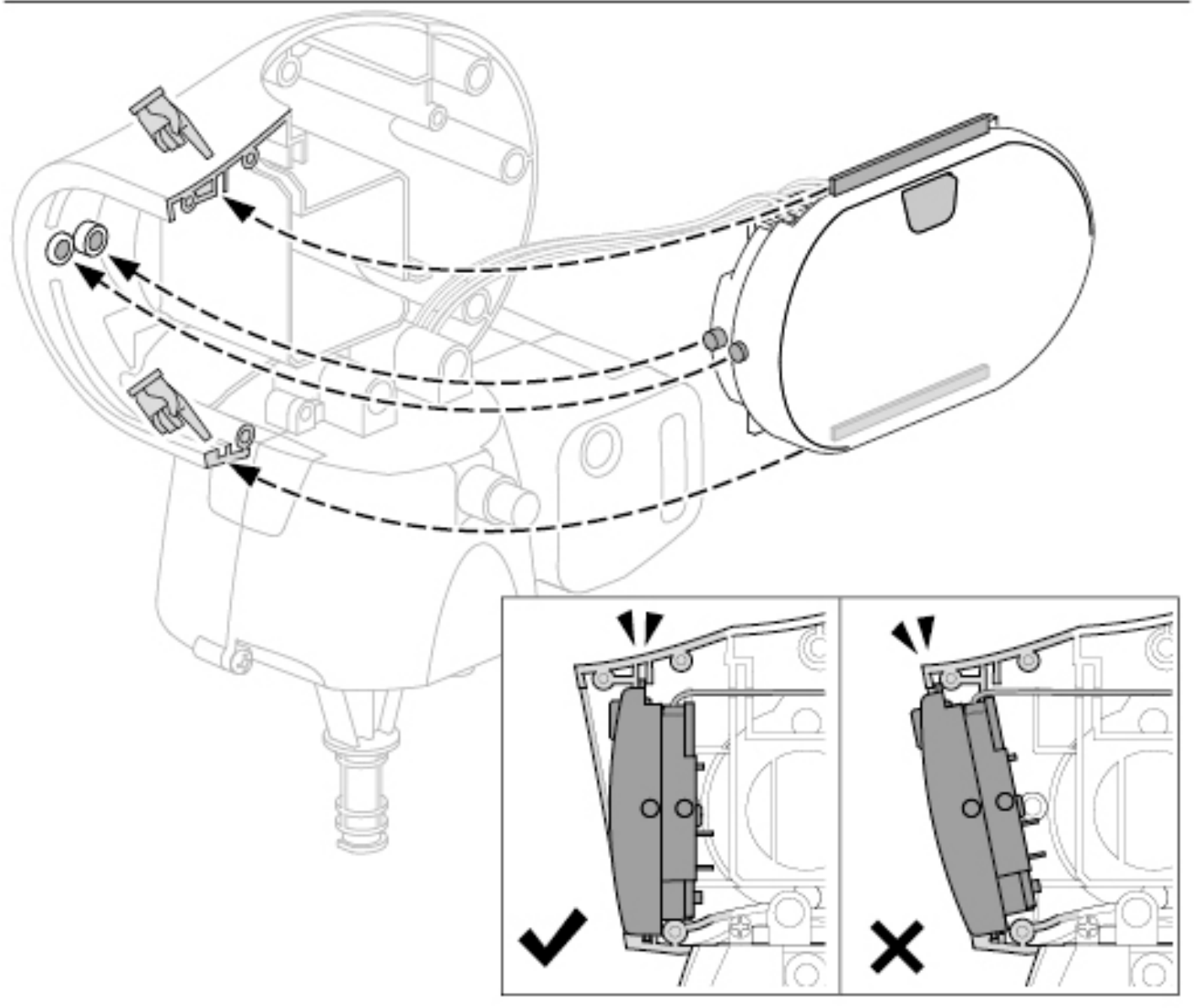
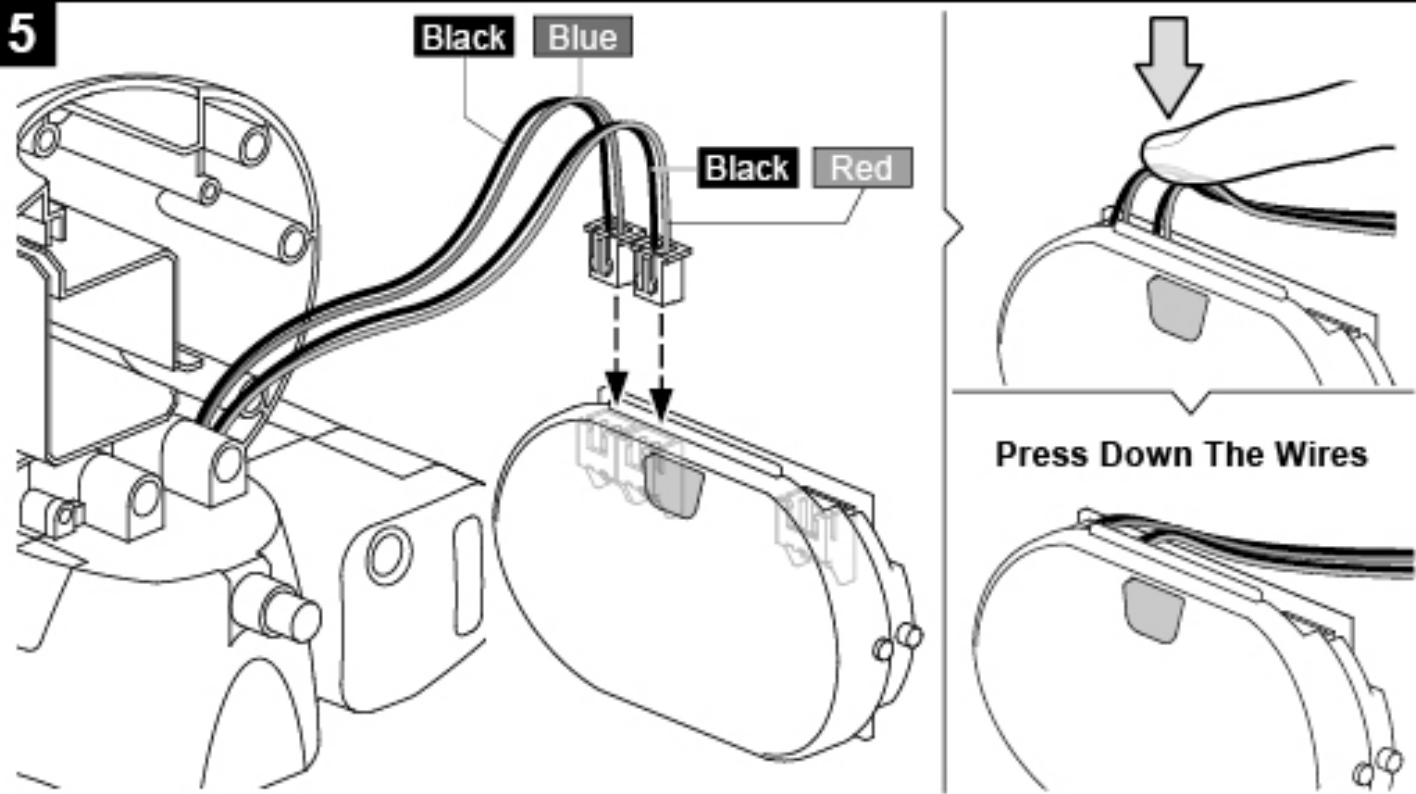

6

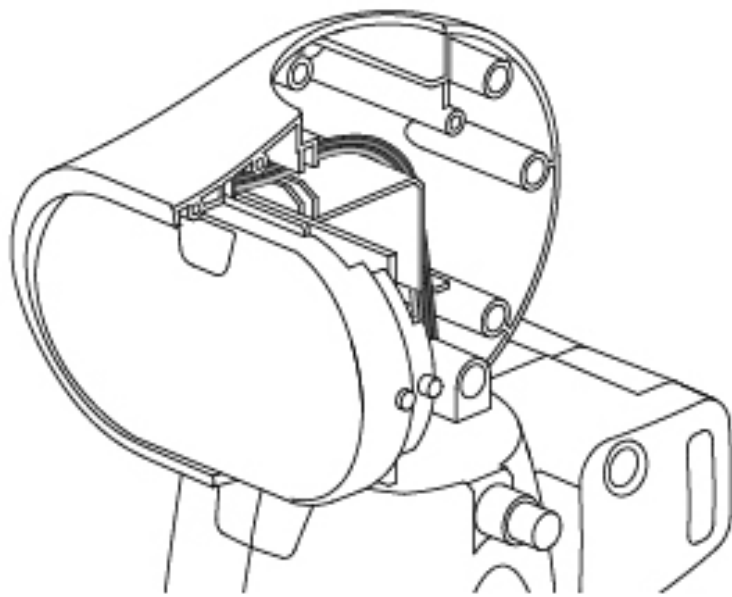
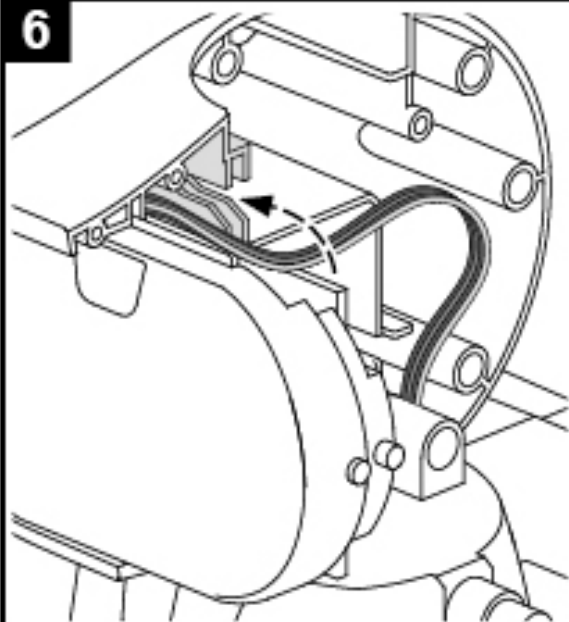

7

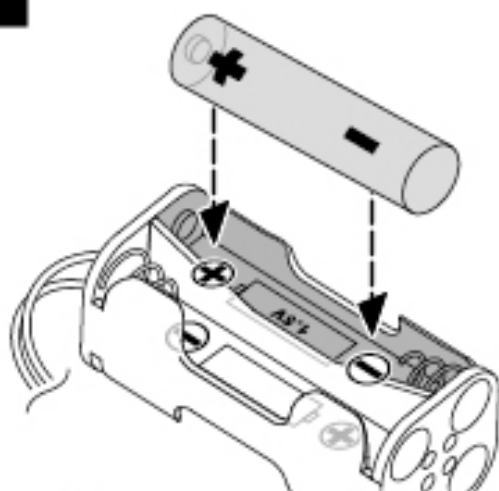

- Removal and replacement of batteries should be carried out by adult or under adult supervision.
- Avoid short circuiting the contacts in the battery compartment or the battery terminals.
- Do not mix used batteries and new batteries or batteries of different types.
- Do not mix alkaline, standard (carbon-zinc), or rechargeable (nickel-cadmium) batteries.
- Batteries are to be inserted with the correct polarity. Do not attempt to recharge non-rechargeable batteries.
- Remove exhausted batteries from the product to avoid leakage.

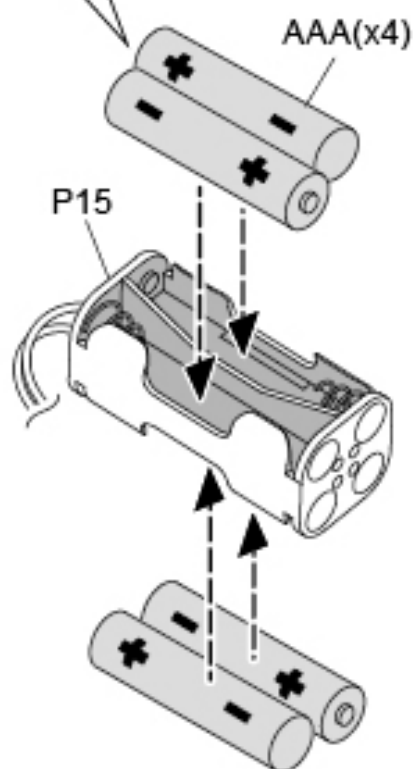

8

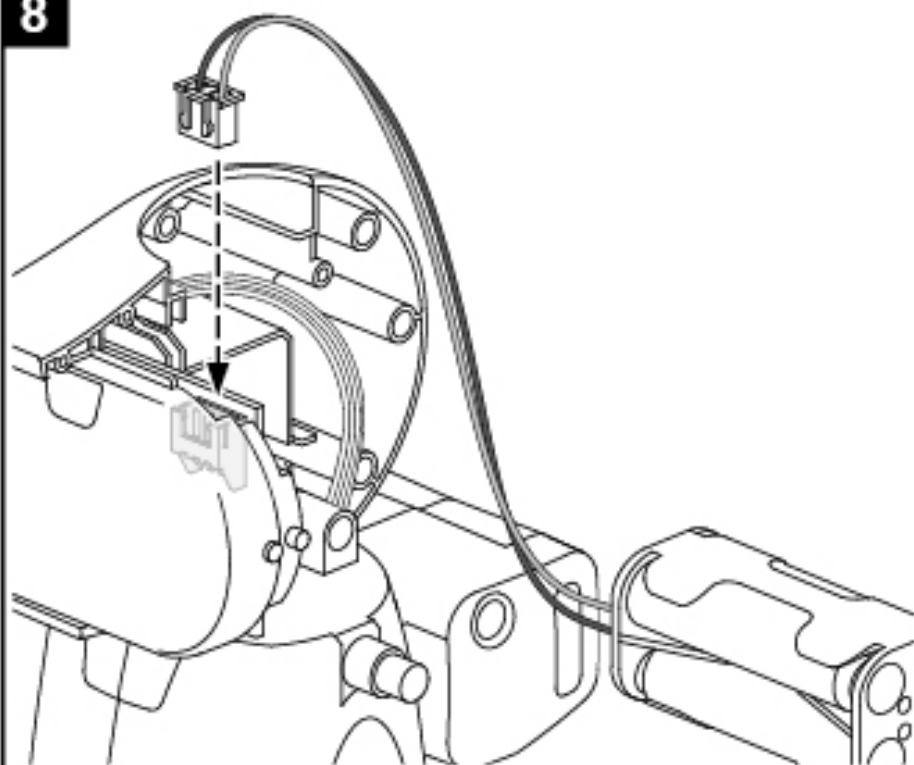

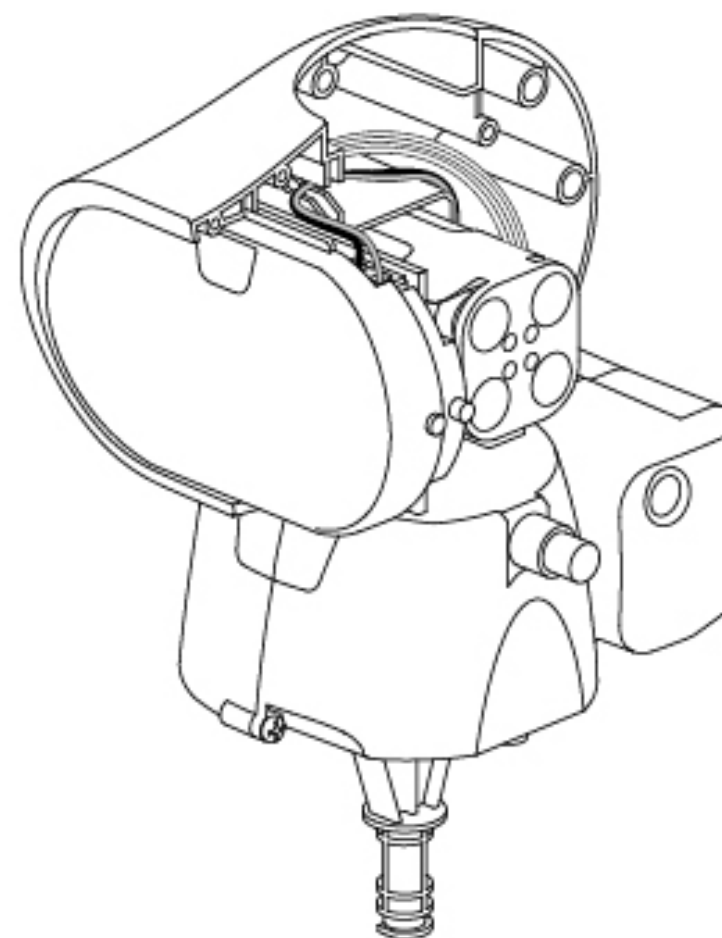
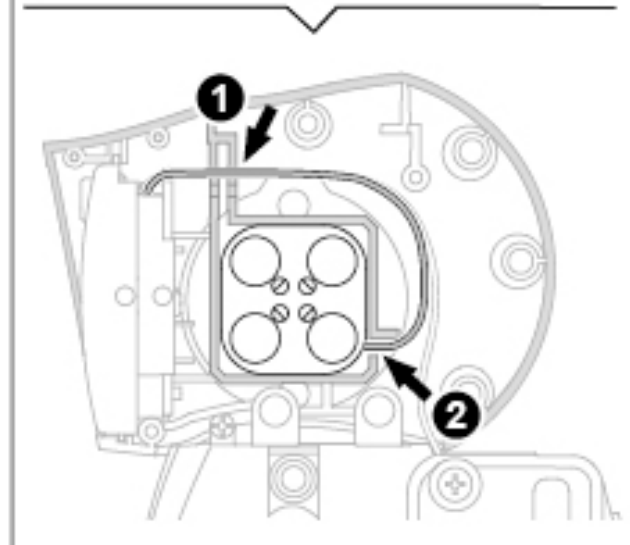
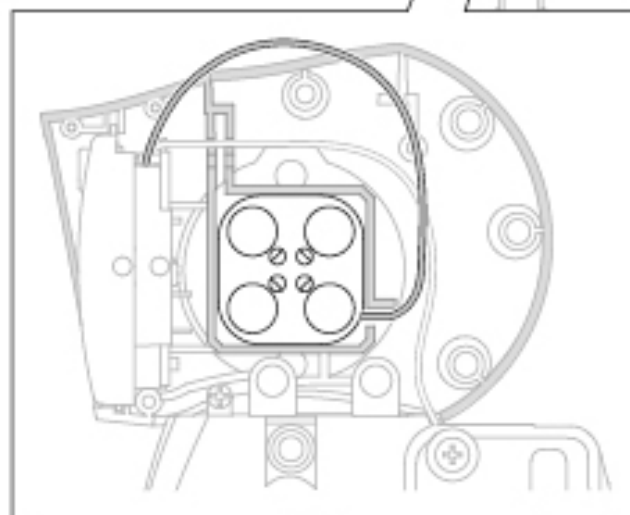
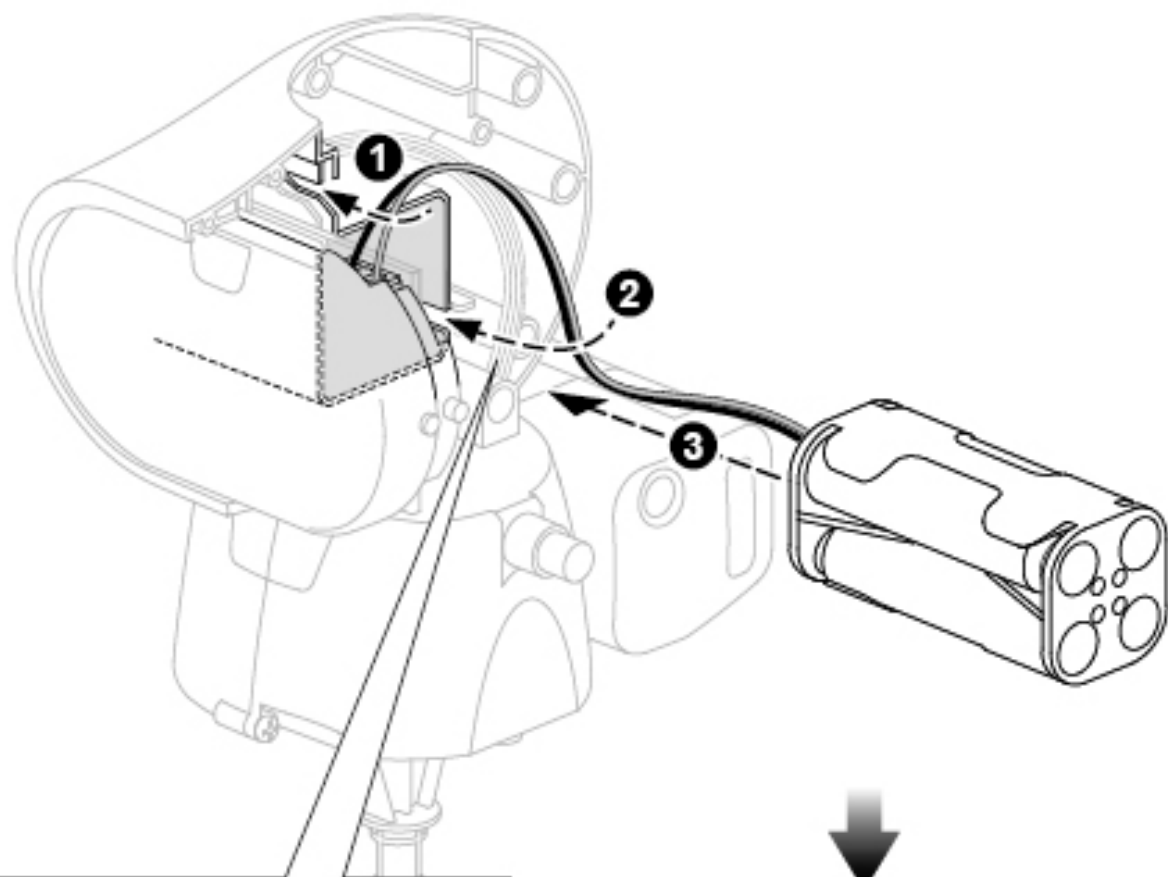

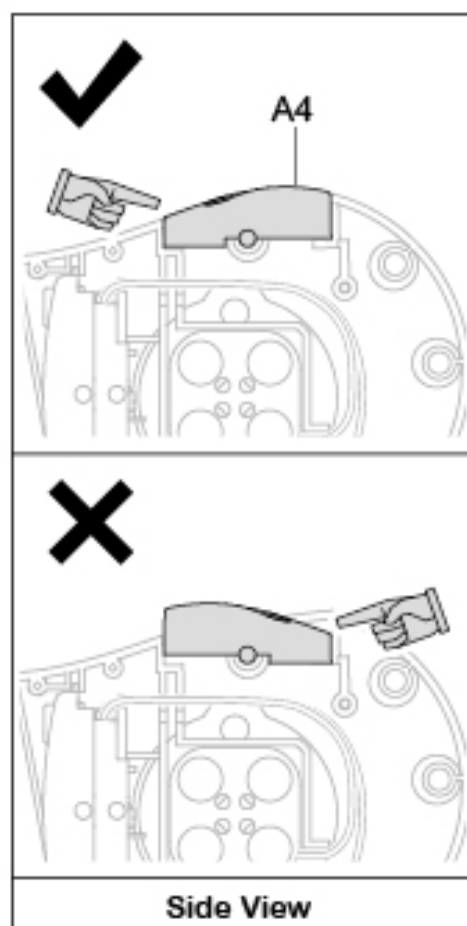
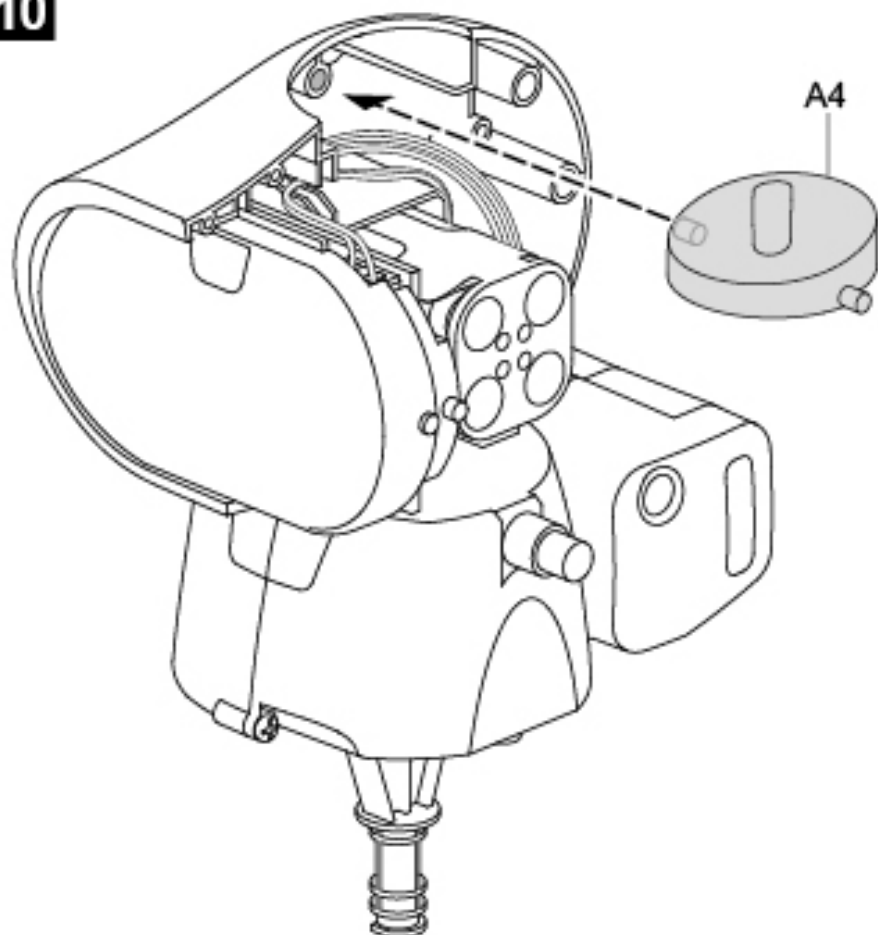
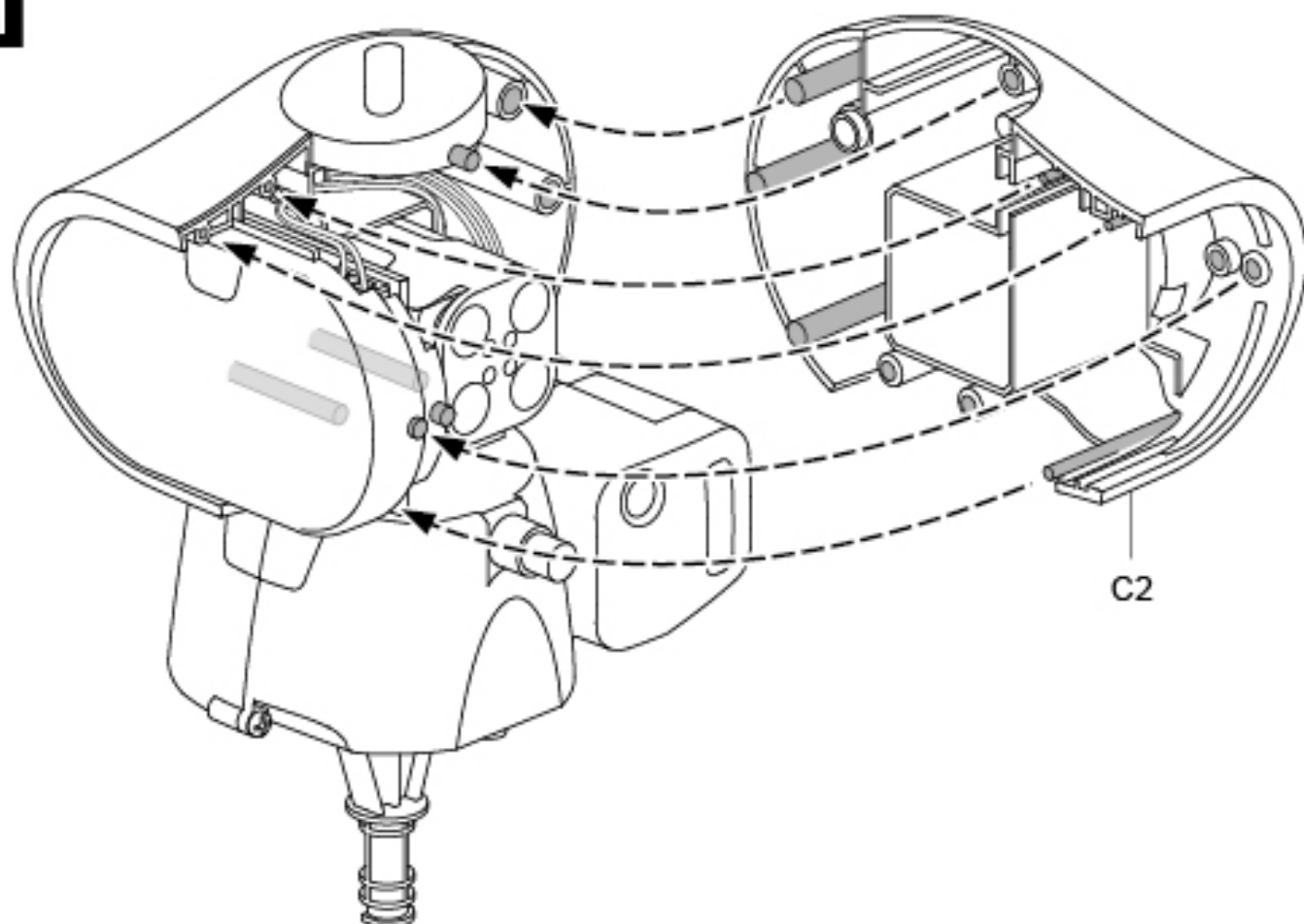
10**11**

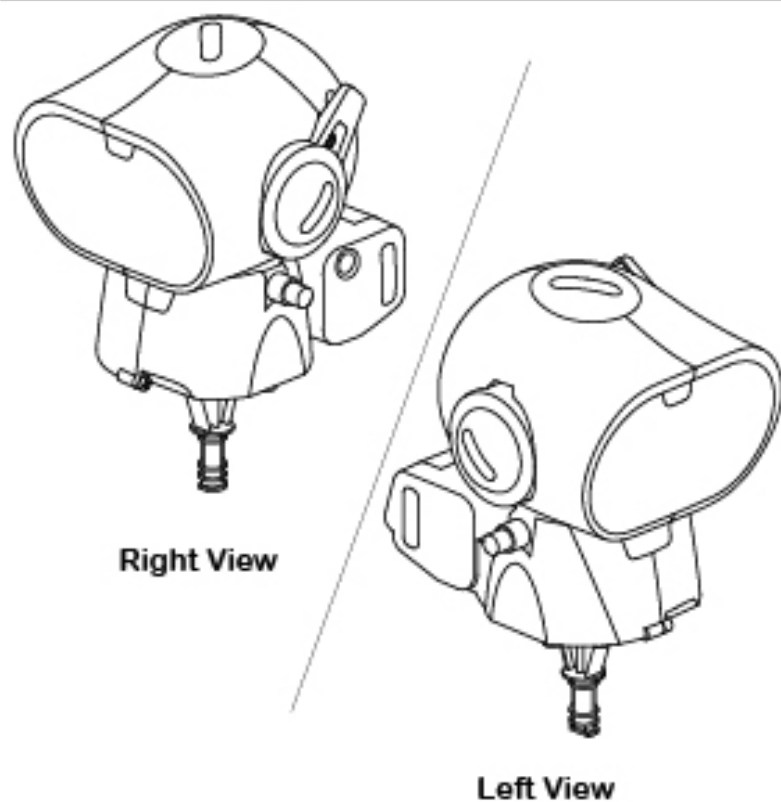
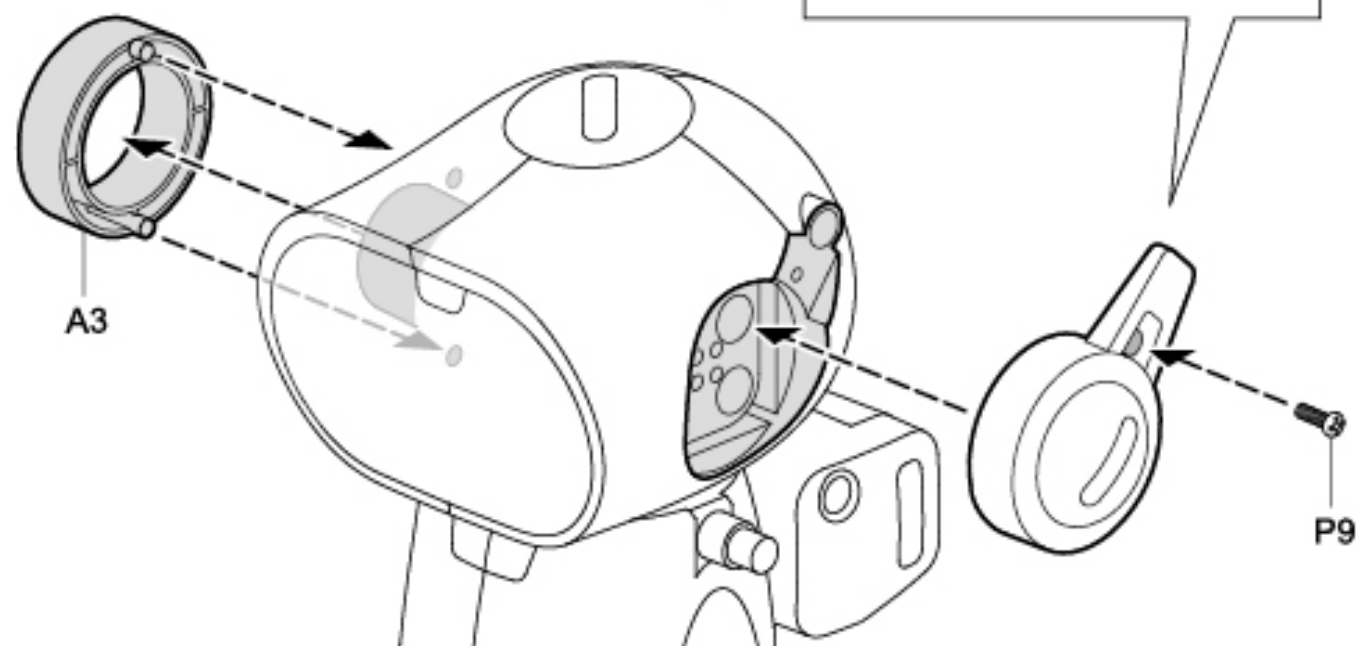
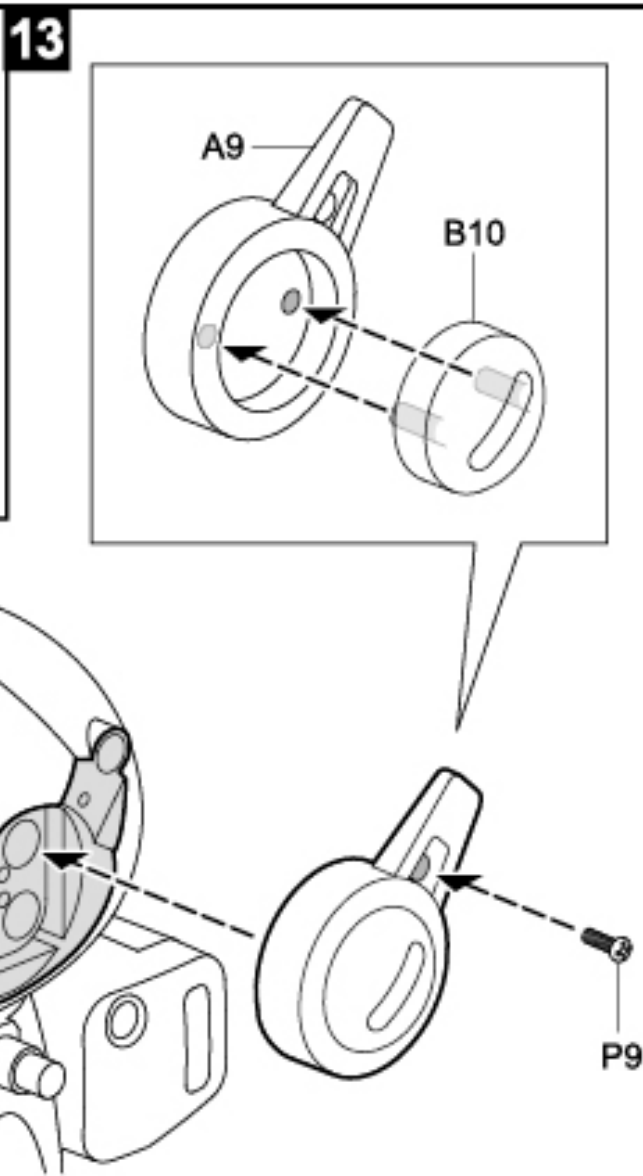
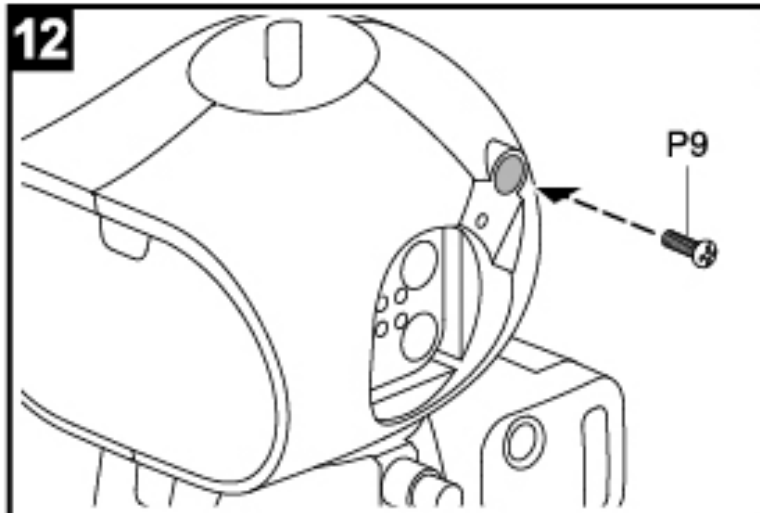

! Cut off the burrs before assembly.

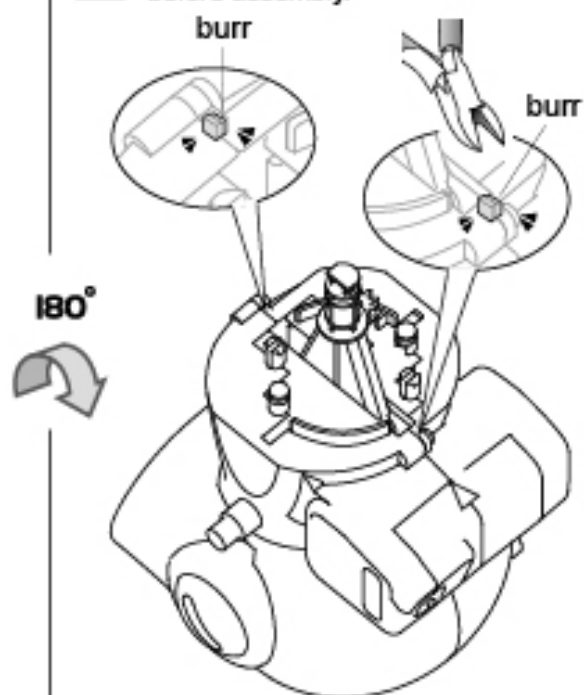

14

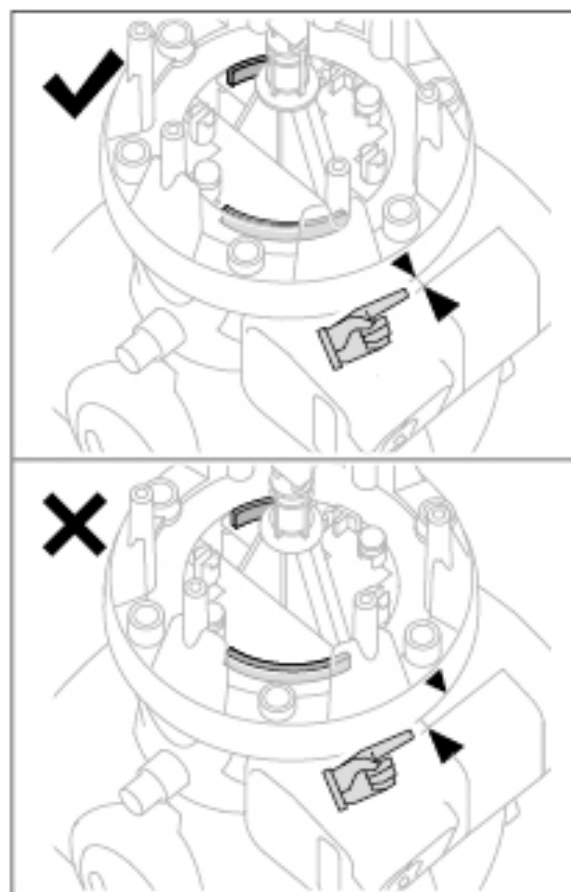
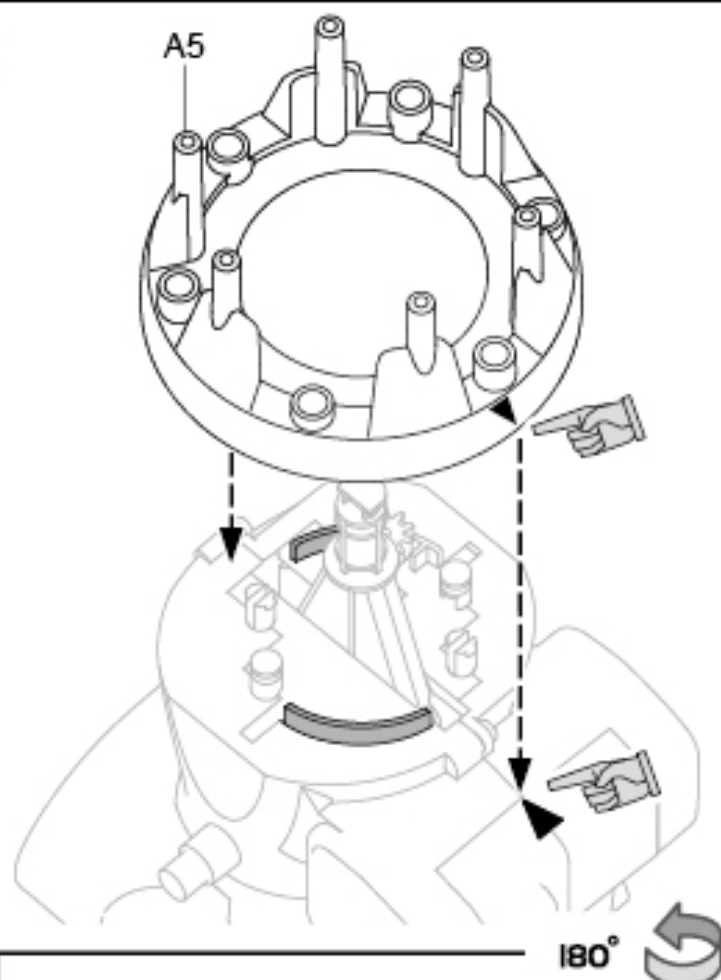

15

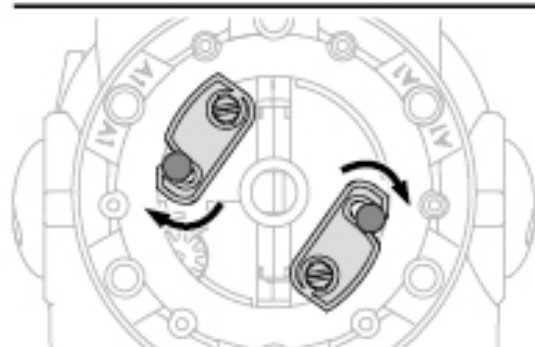
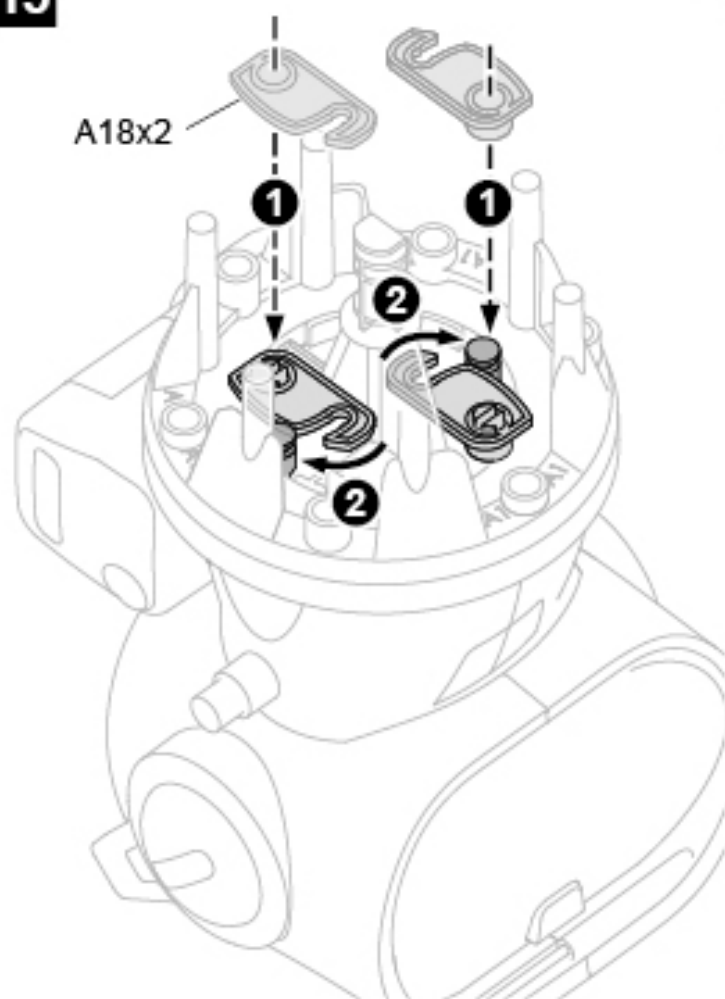

! Make sure to snap on A18 with a "Click"

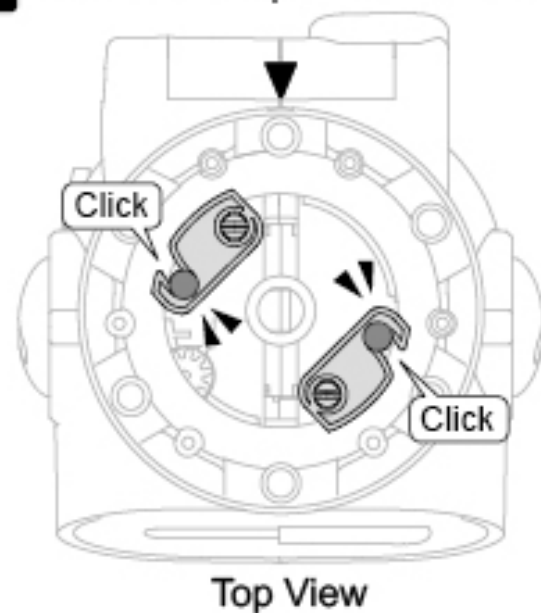

16

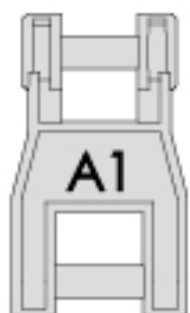

Scale 1:1



! Don't mix up
A1 & A2.

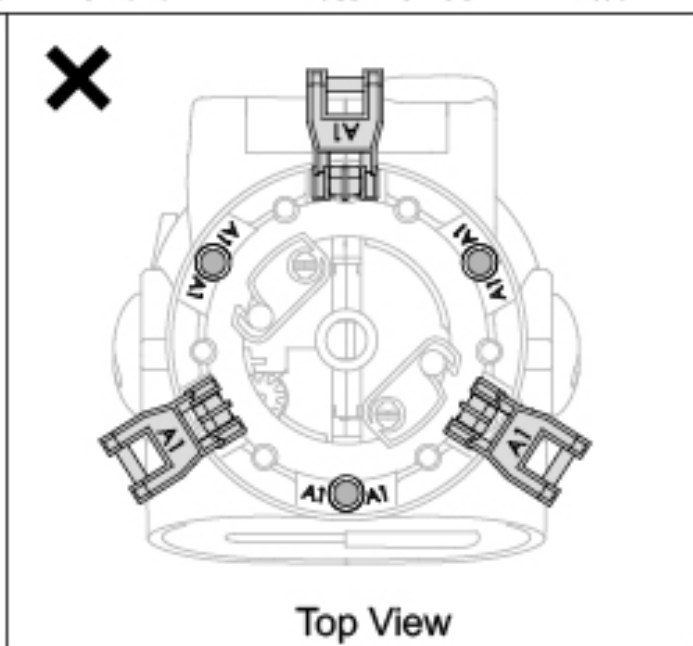
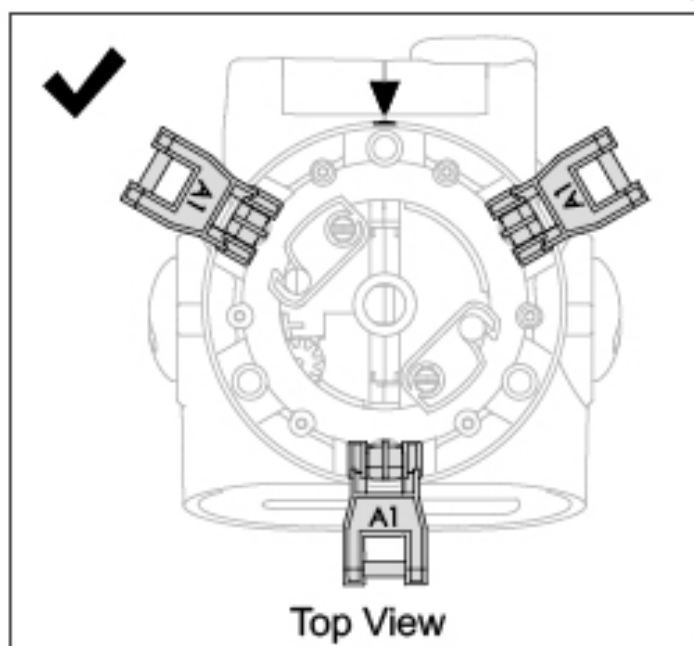
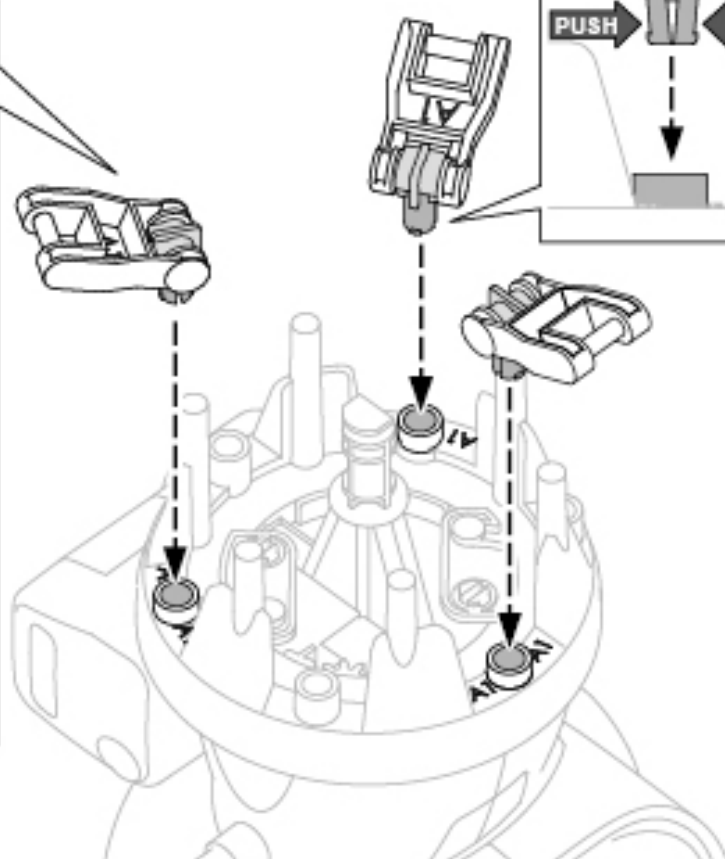
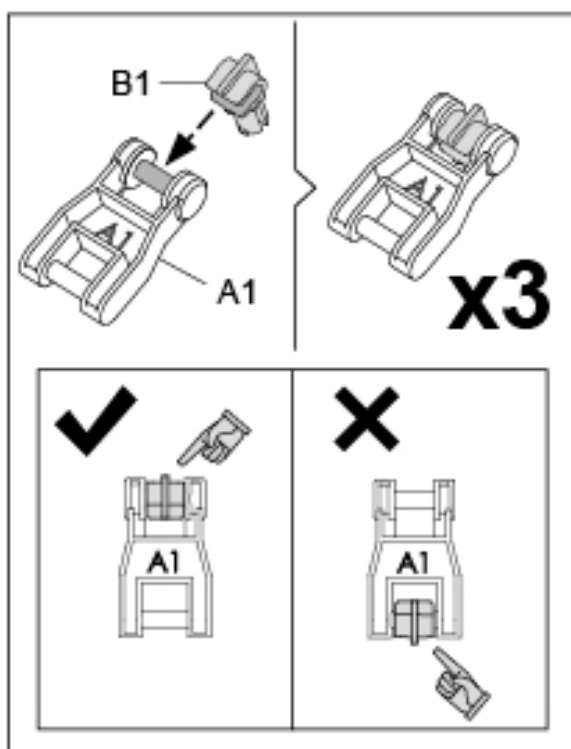
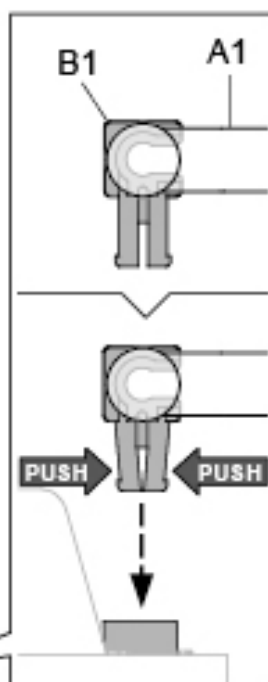

17

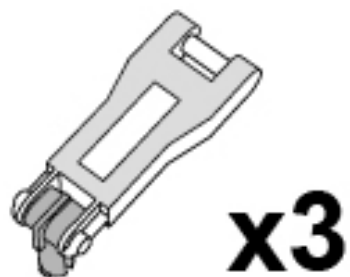
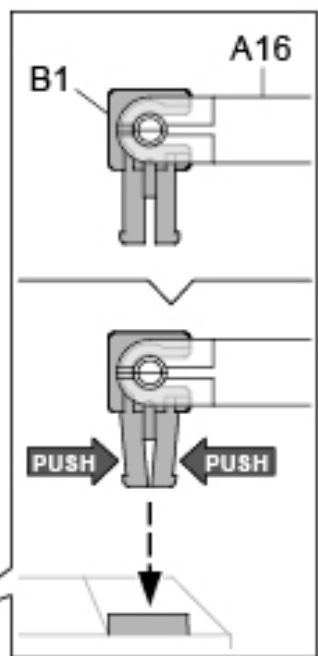
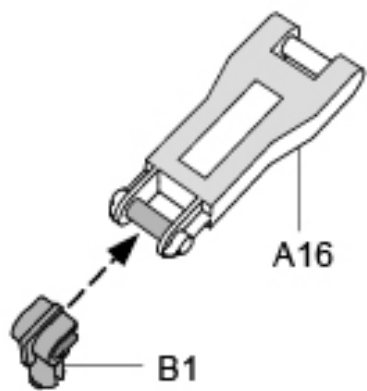

x3

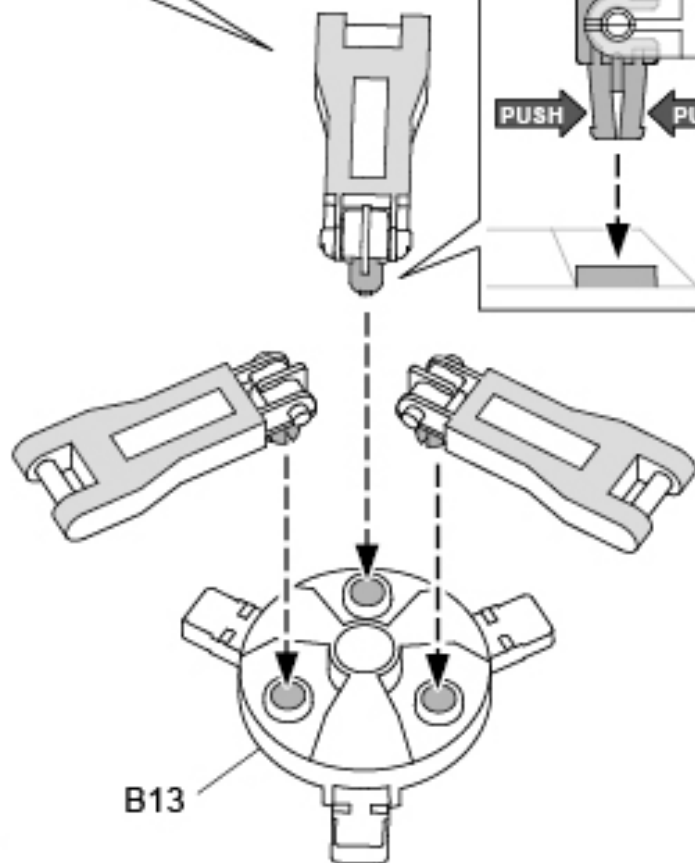
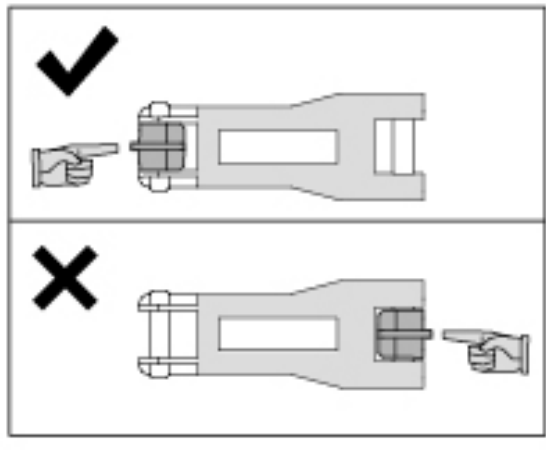

18

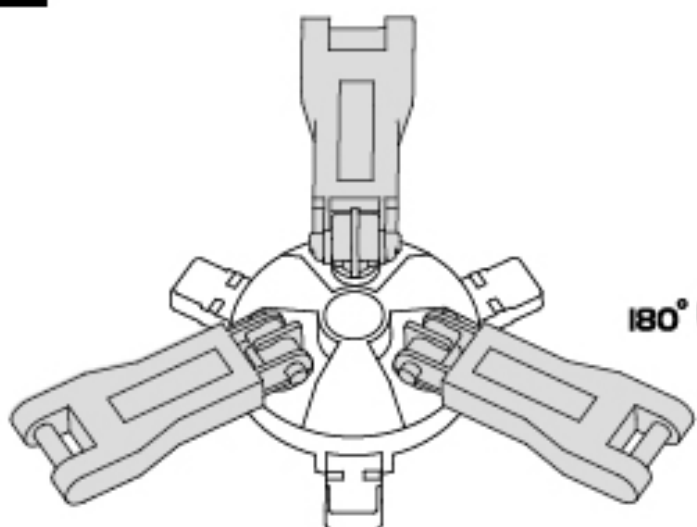

180°

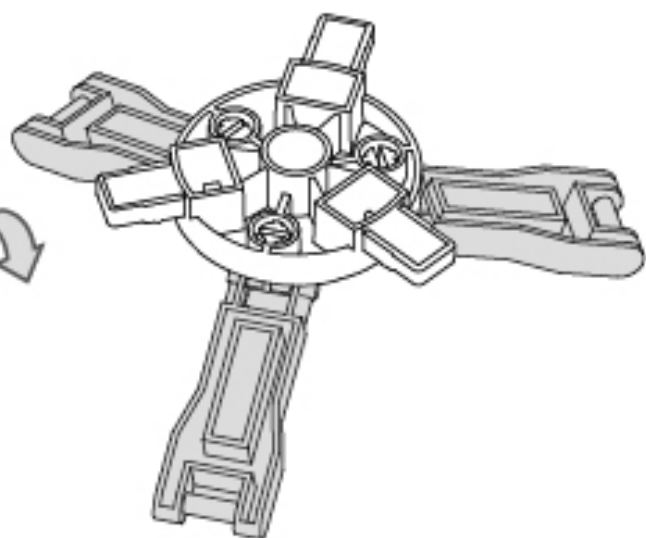

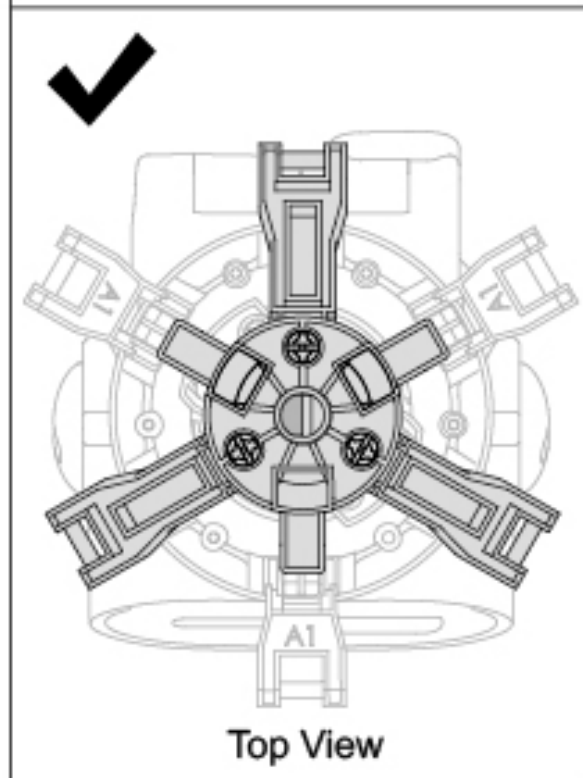
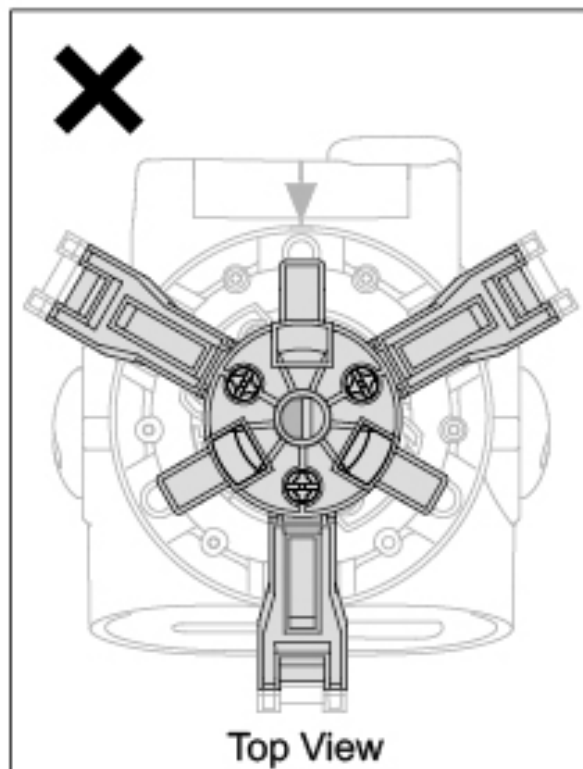
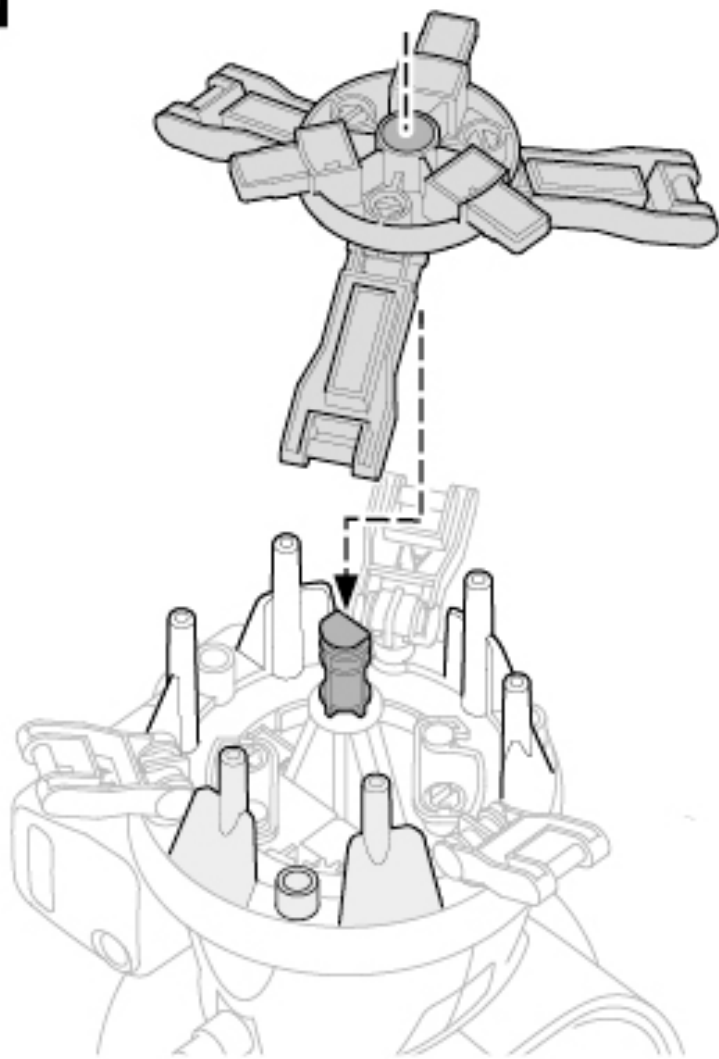

20

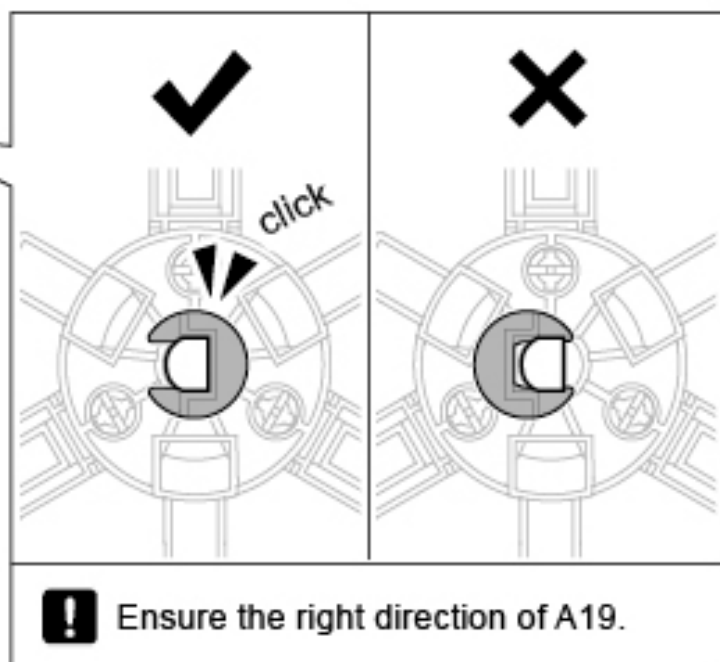
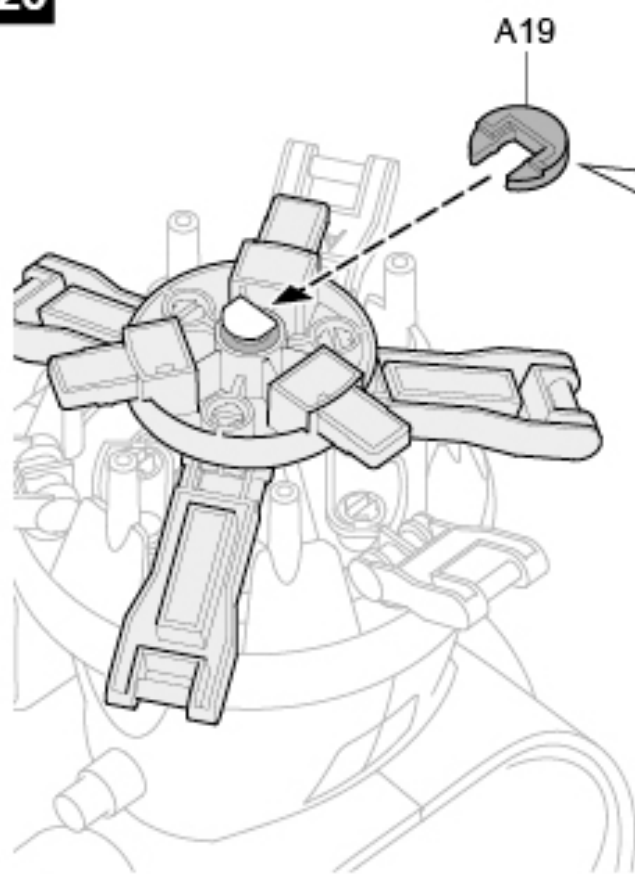

21

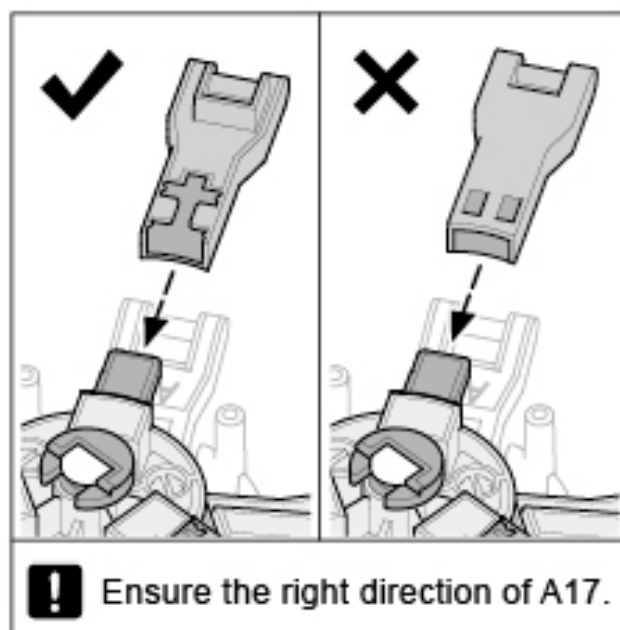
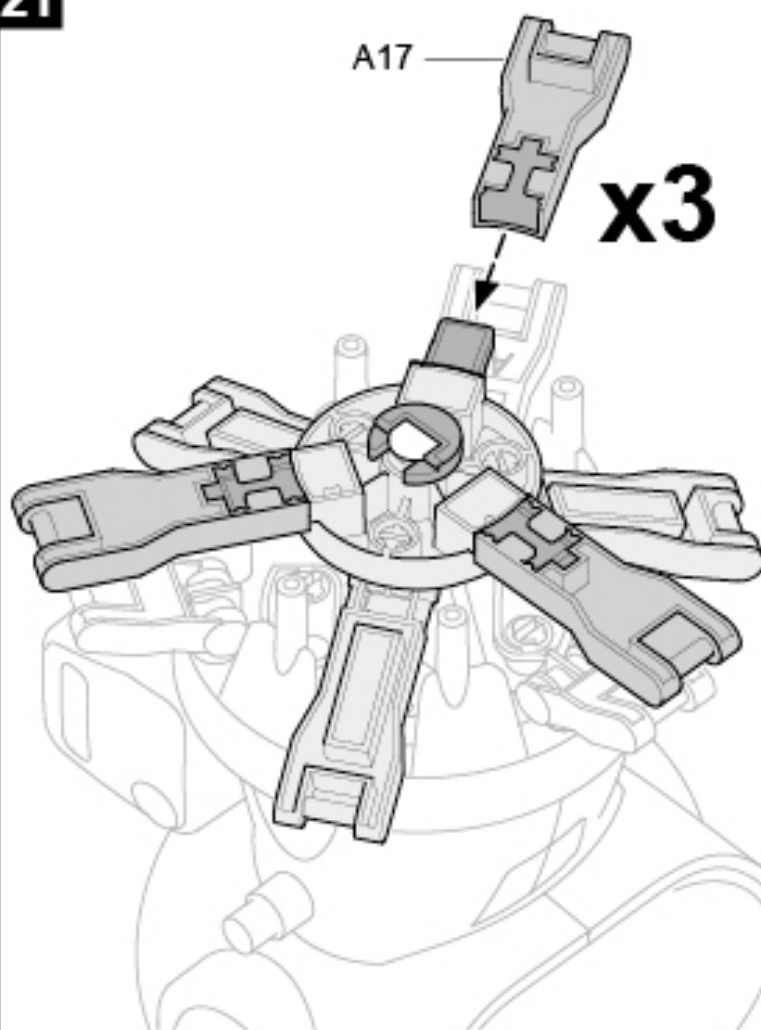

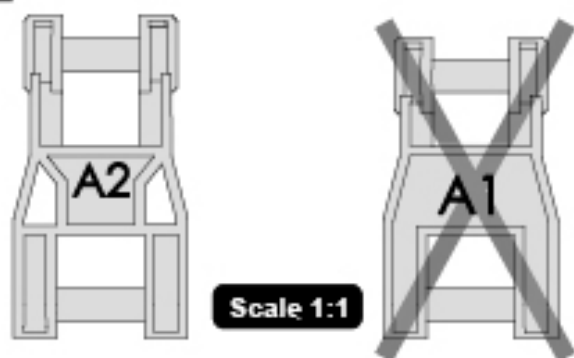

! Don't mix up A2 & A1.

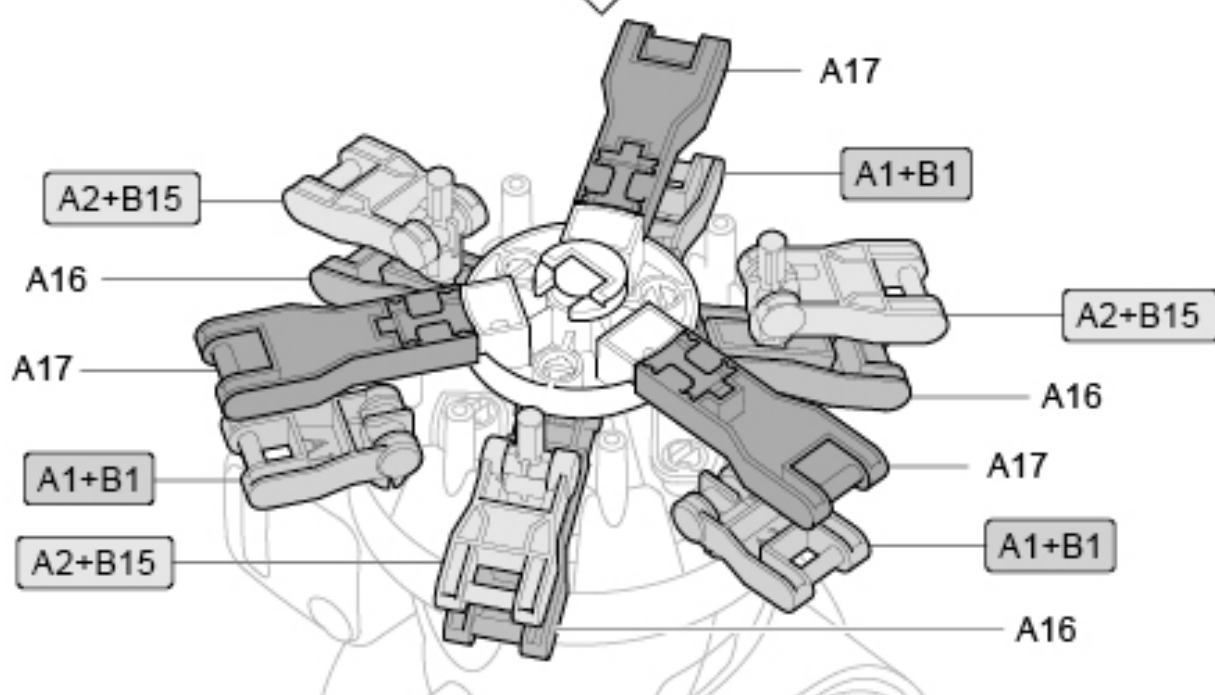
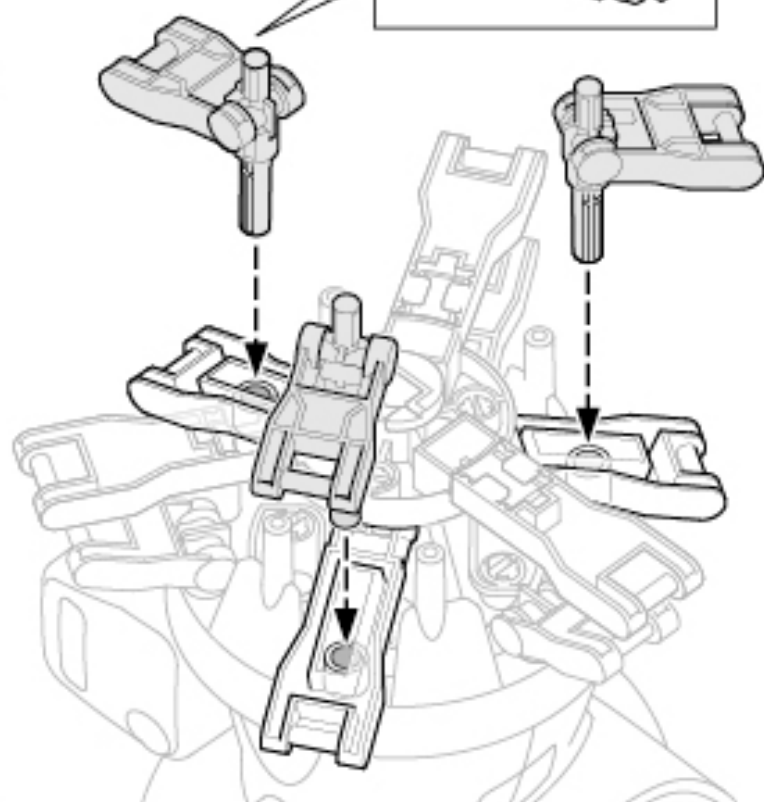
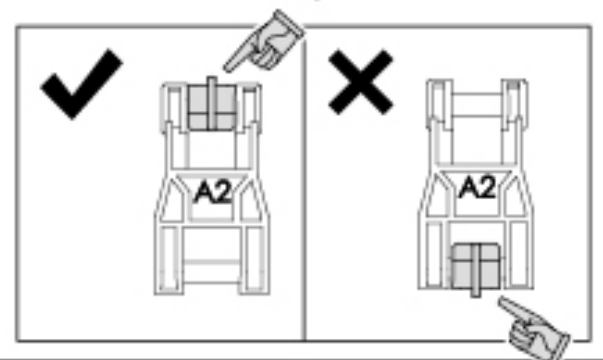
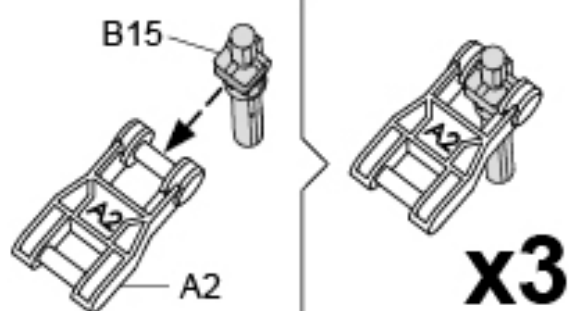
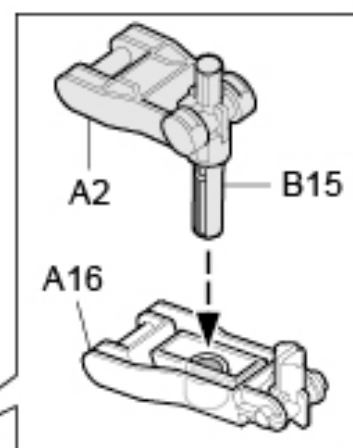

23

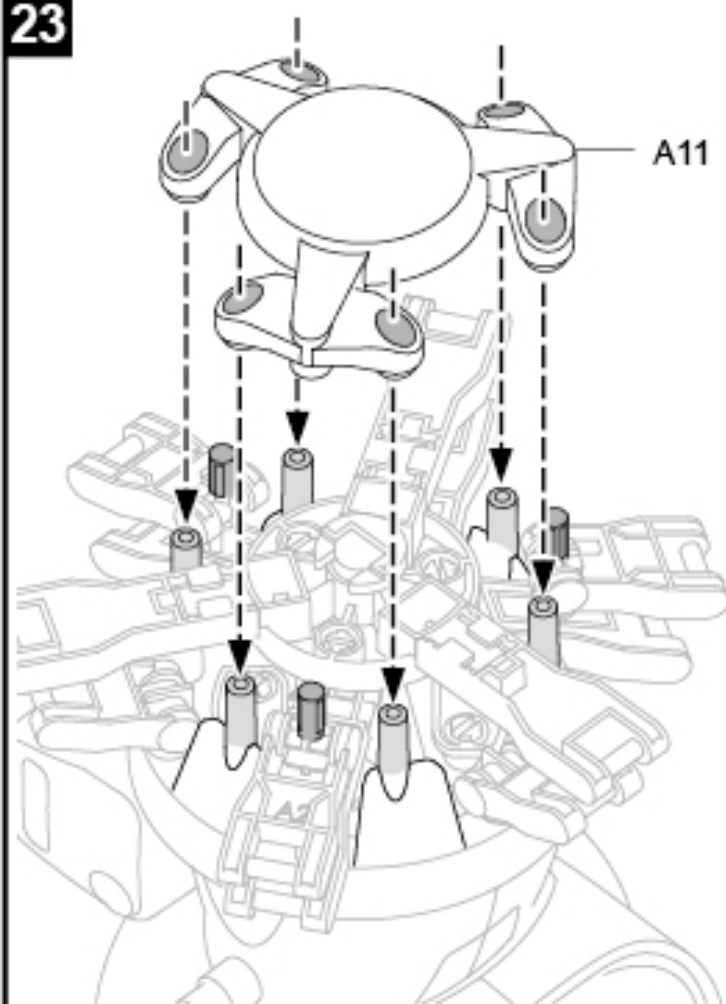

24

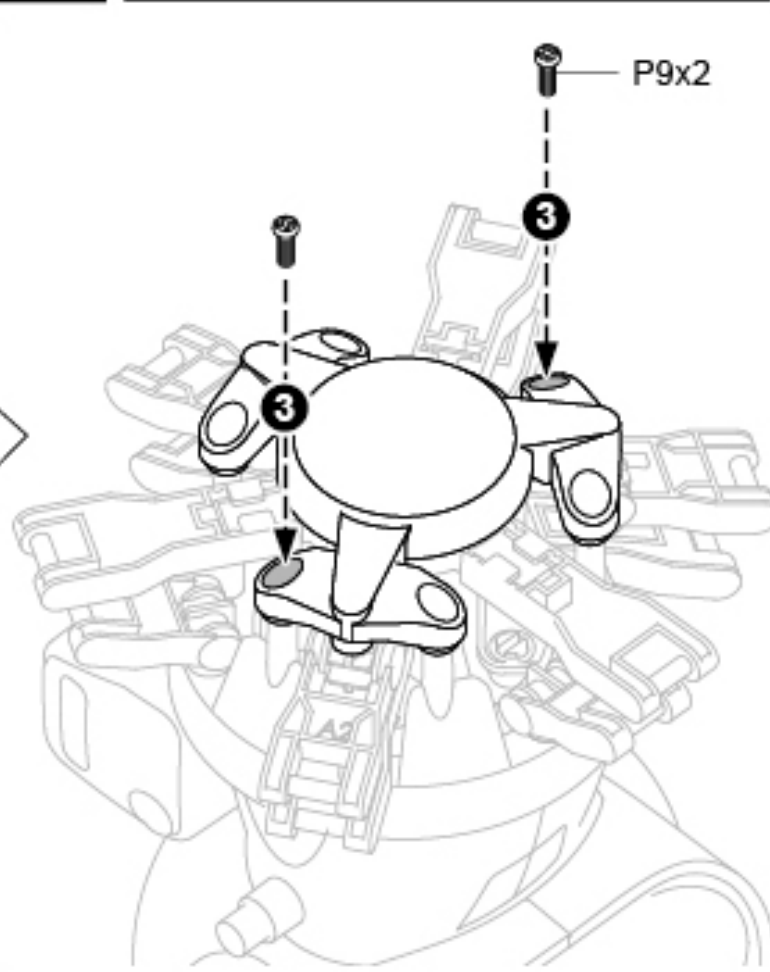
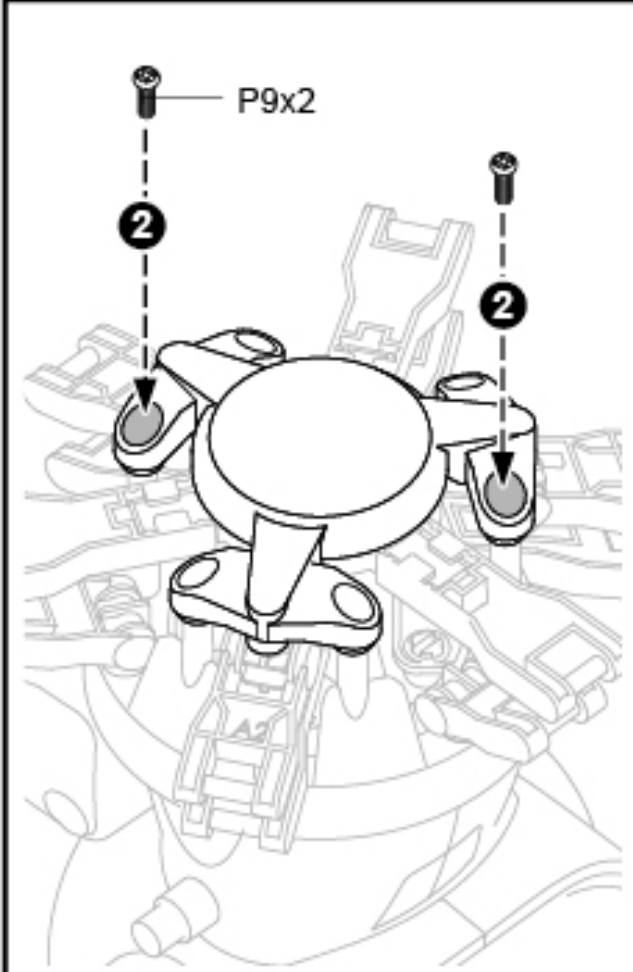
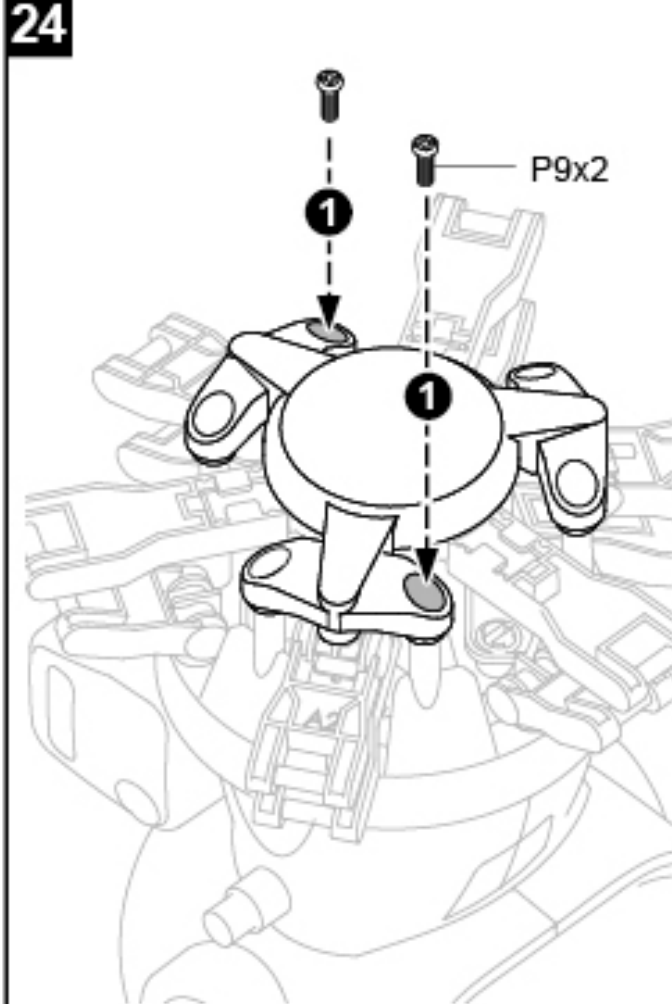

Feet & Arms Module Assembly

1

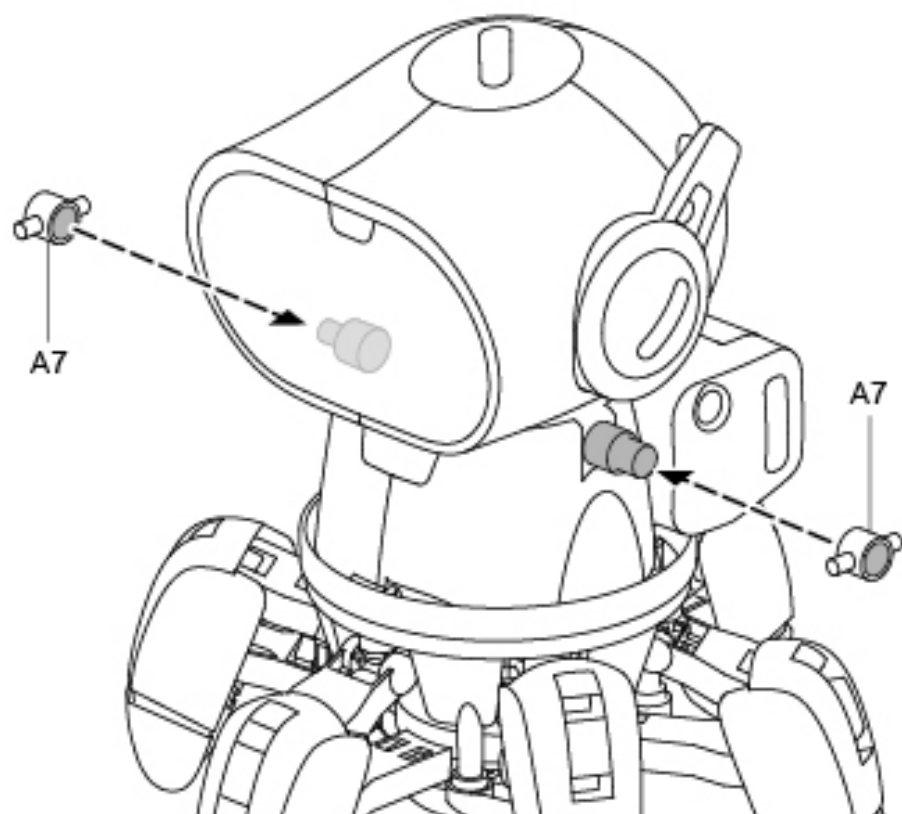
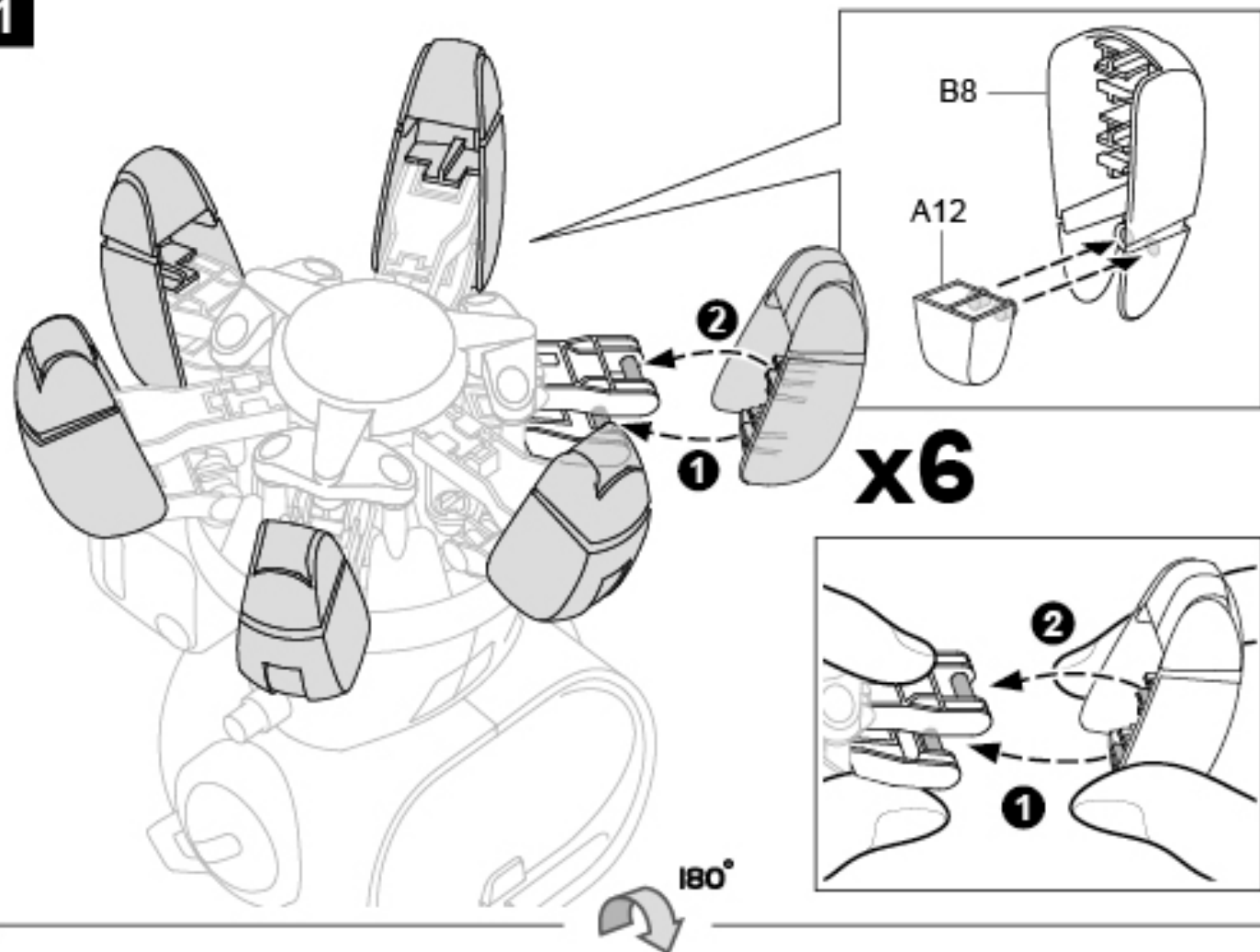

2

Arm R

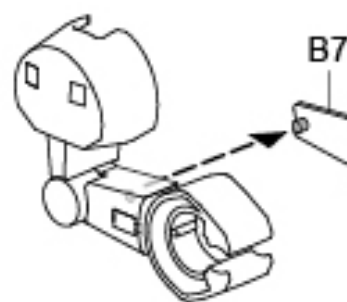
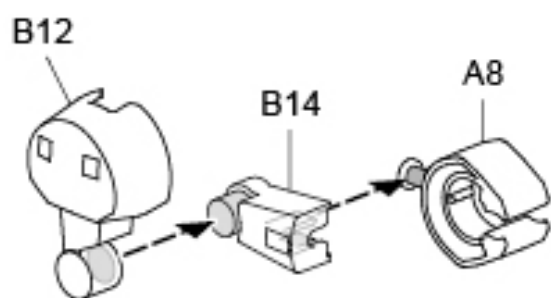

! Cut off the burrs before assembly.



Arm R

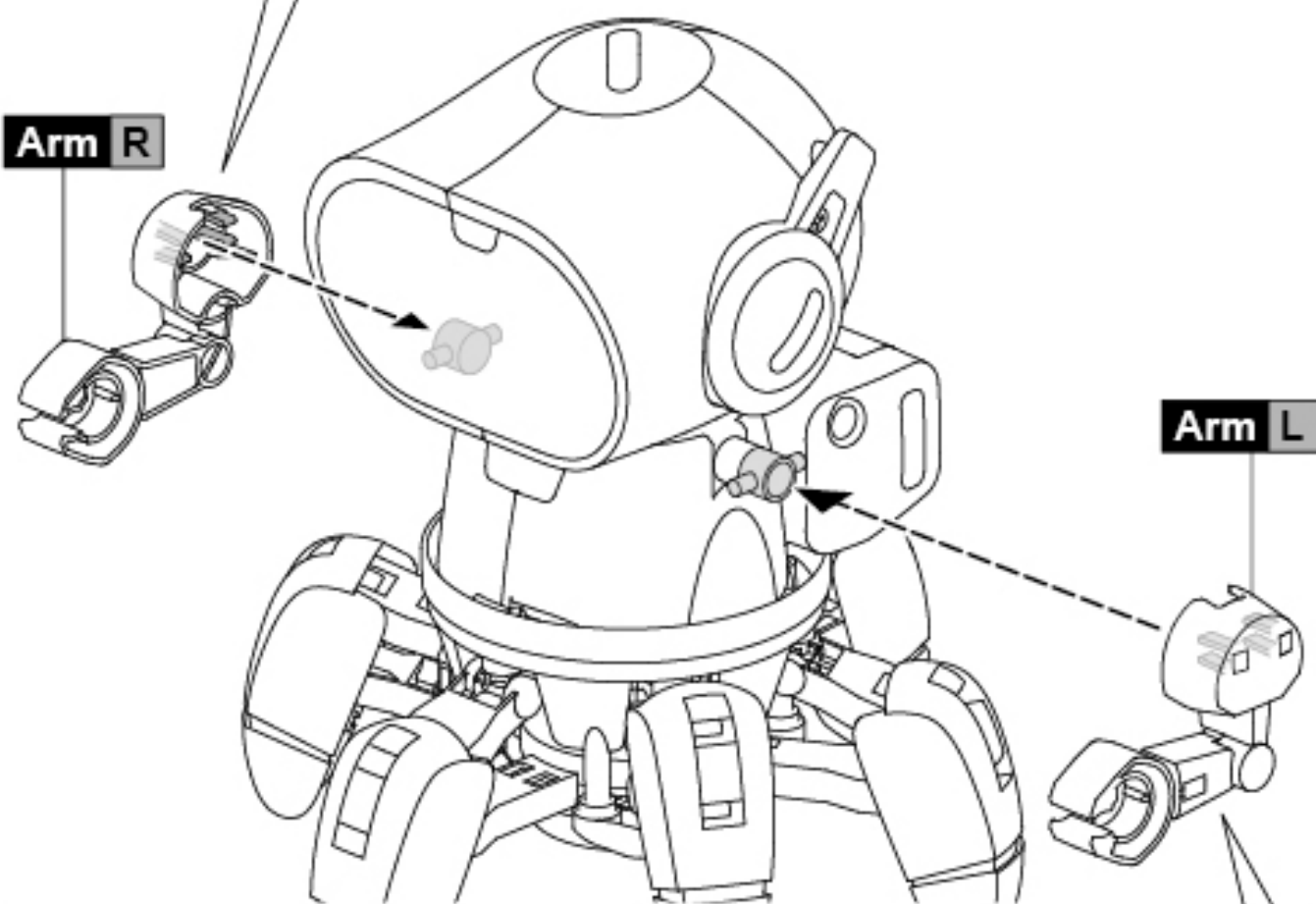

Arm L

Arm L

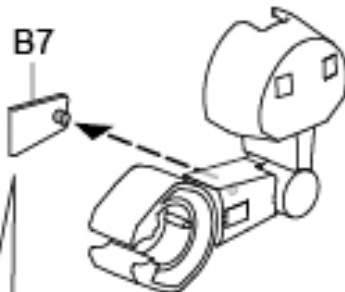
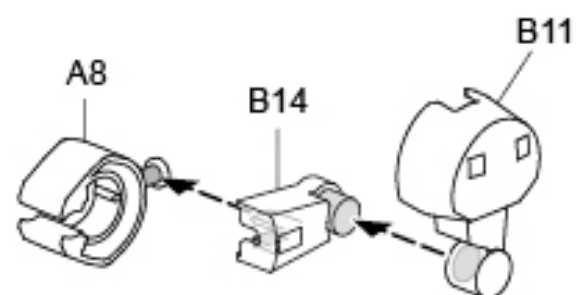

! Cut off the burrs before assembly.



3 Finish

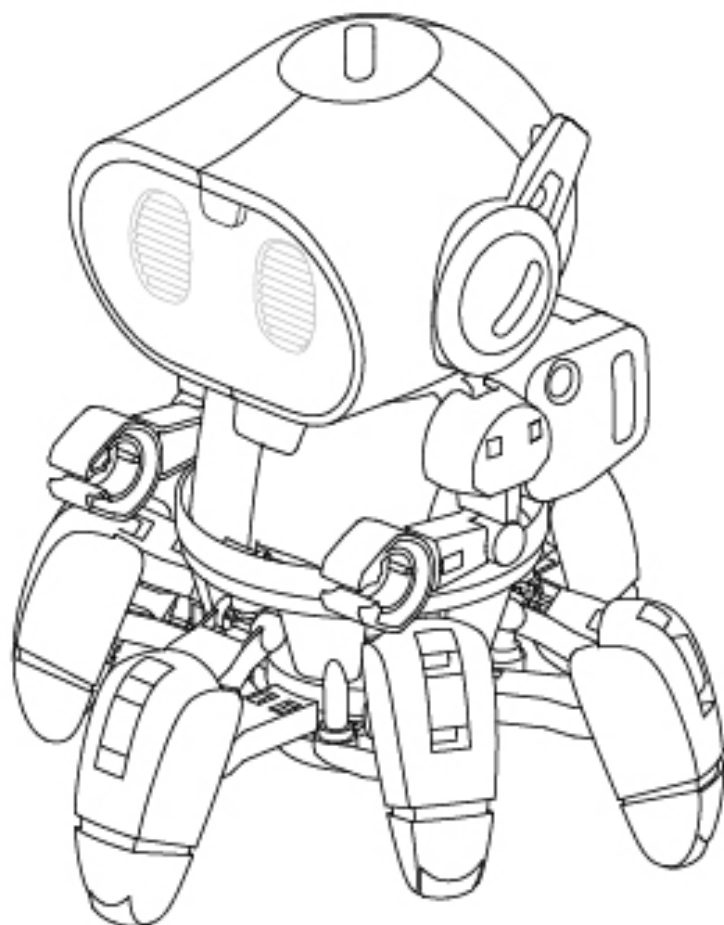

How To Replace Batteries

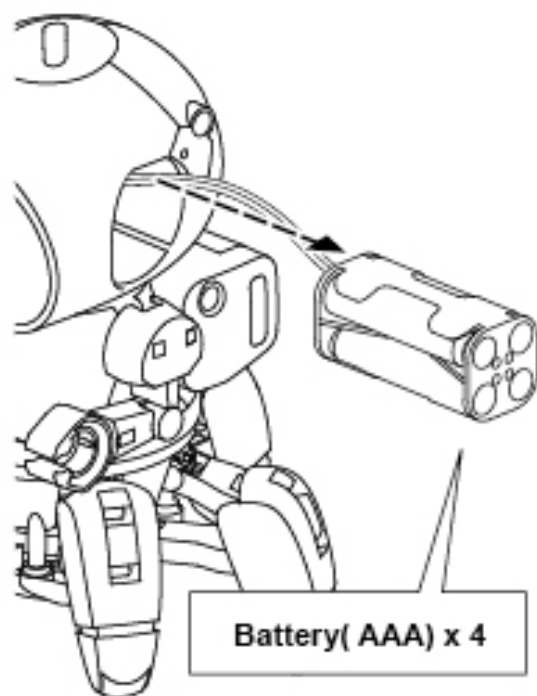
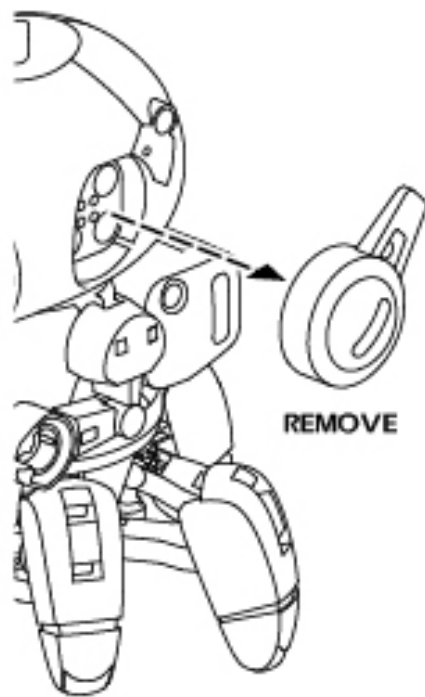
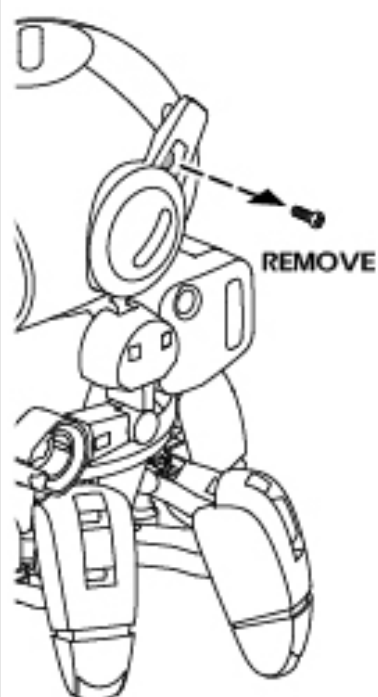

How To Play

1 Power On - " Standby " Phase

1. Long-press the switch for 2 secs. Tobbie's eyes (LED) light up with sound effects
2. LED flashes → enter " Standby " phase → select playing mode.

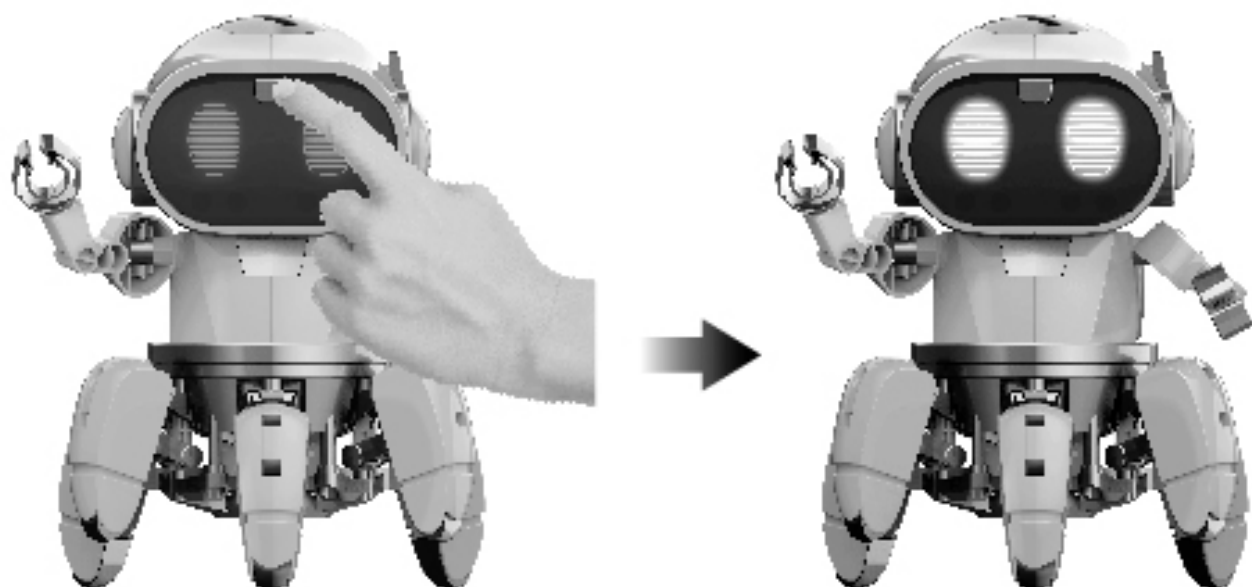

Note: Do not keep Tobbie waiting too long, Tobbie will keep stamping its feet with sound alerts to remind you. If " Standby " phase stays more than 60 secs without mode selection, Tobbie will " power off ".

2 Two Interactive Modes

One single button to switch between modes (Funway 1 / Funway 2) alternatively
Example:

- Press the switch once- LED (left) lights up → goes into mode "Funway 1 "
- redo(repress button) - LED (right) lights up → goes into mode "Funway 2"
- redo(repress button) - LED (left) lights up → goes into mode "Funway 1 "

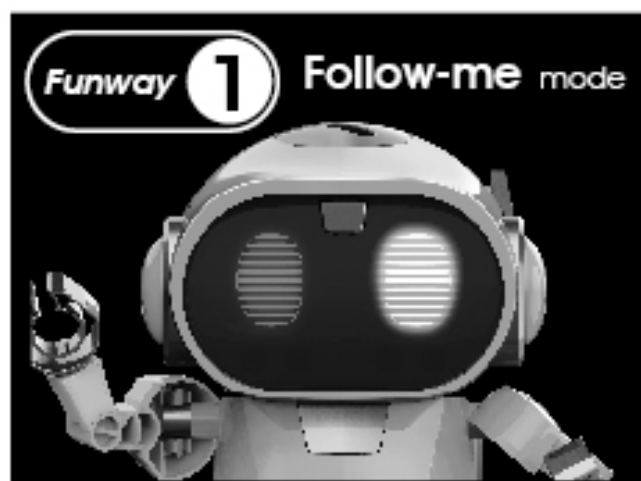

Funway 1

Follow-me
mode

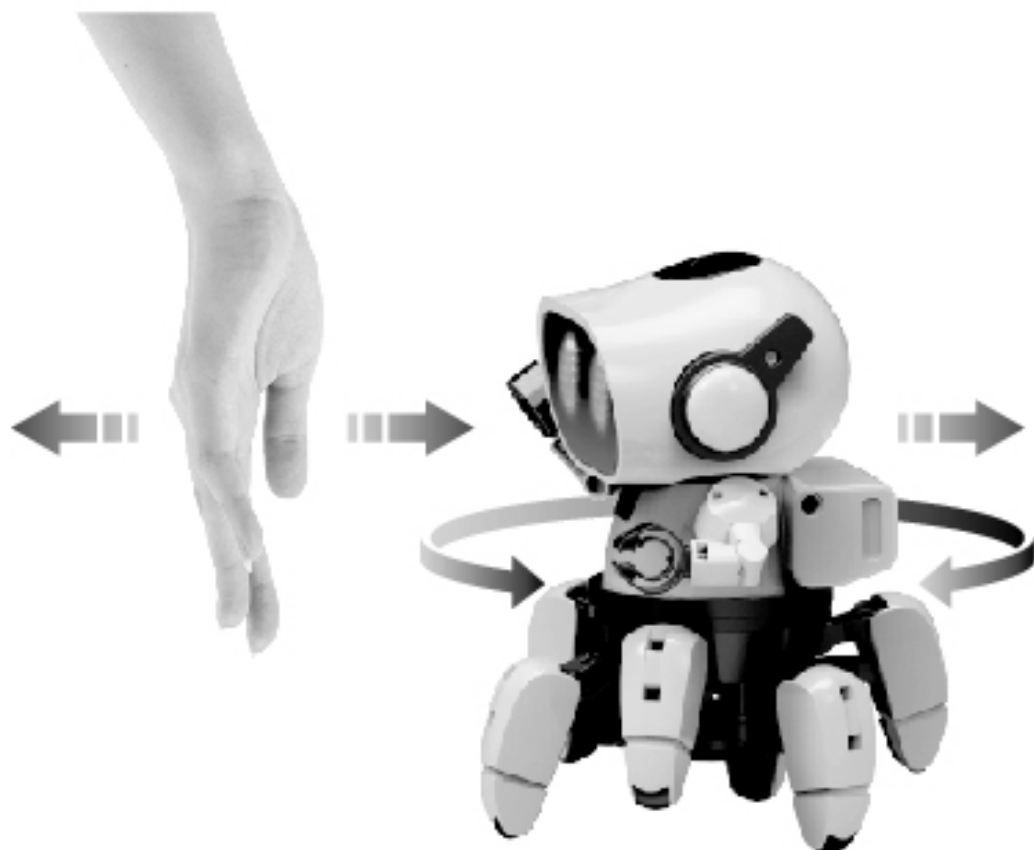

Funway 2

Explore
mode

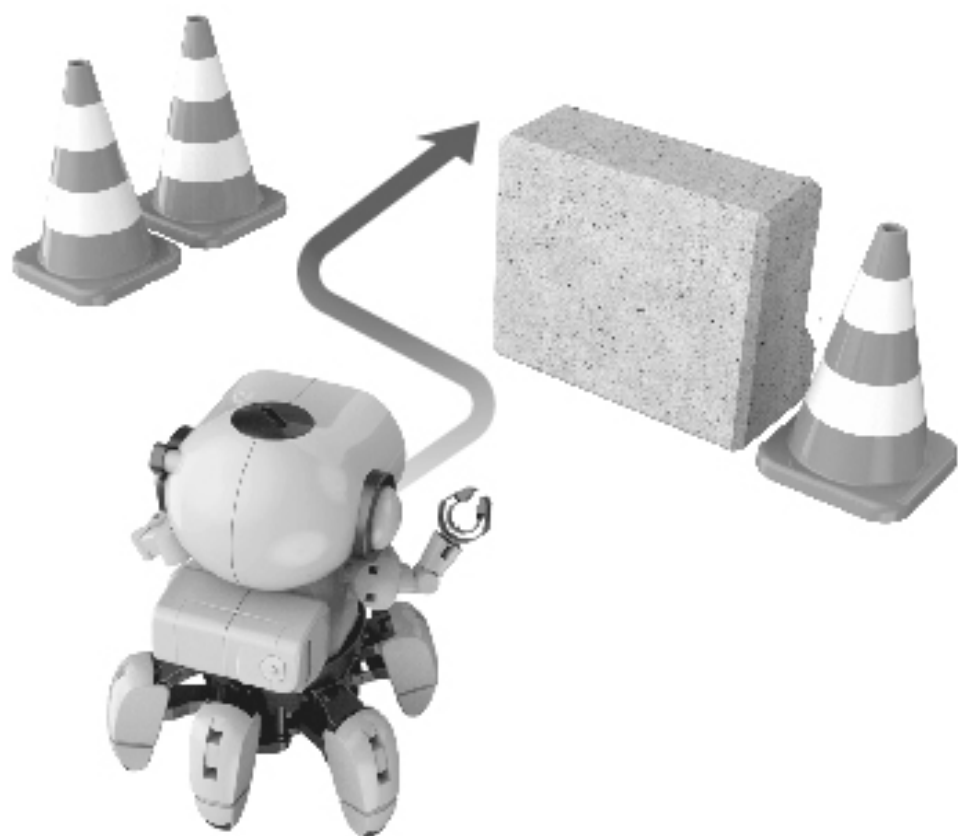

3 Power Off

Long-press the switch for 3 secs.

Tobbie becomes inactive, its LED eyes/Sound effects fade and then power off.

Tobbie goes into " power off " mode.

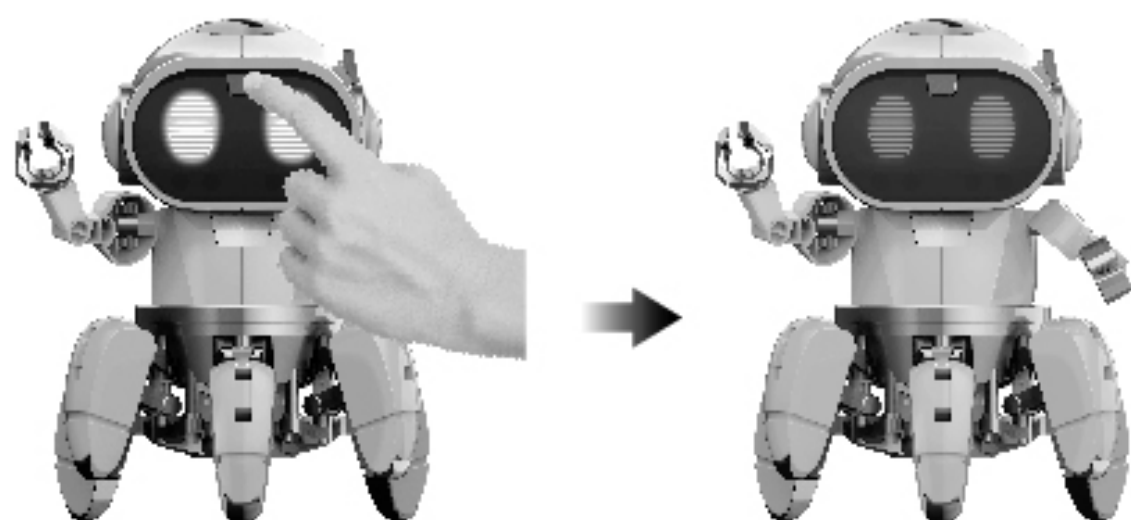

Warning

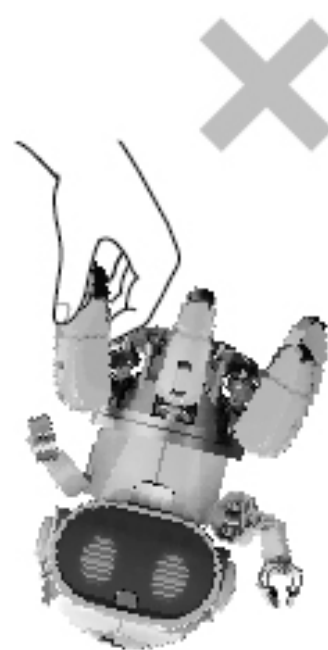
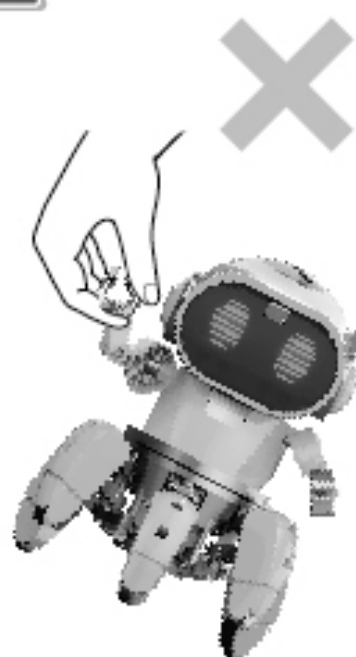
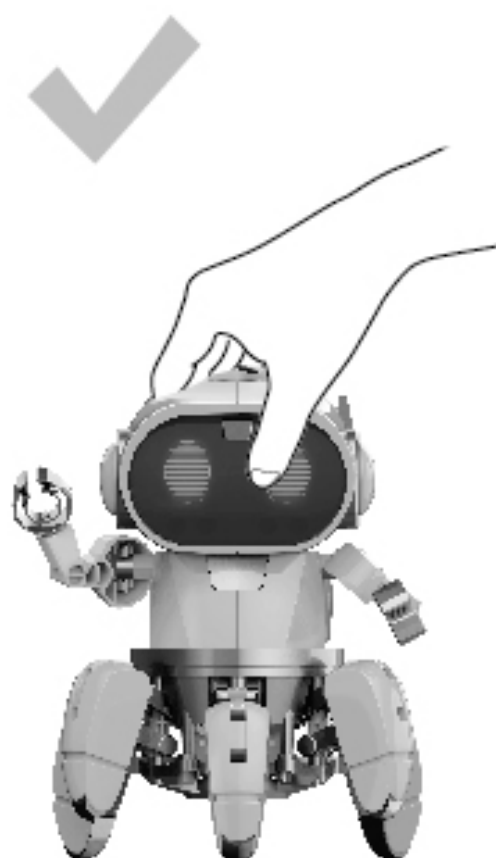

Be gentle when holding Tobbie by its head, any improper motions (as shown to the right) might cause malfunction.

Trouble Shooting

1. Ensure batteries are placed in correct polarity. (refer to page 13, step **7**)
2. If Tobbie does not work (LED doesn't flash) when pressing " power switch ",
Check and ensure the screws are fastened to the bottom entirely
(refer to page 11, step **3**)
3. Ensure all wirings are correct (refer to page 12, step **5** wire configuration as below)

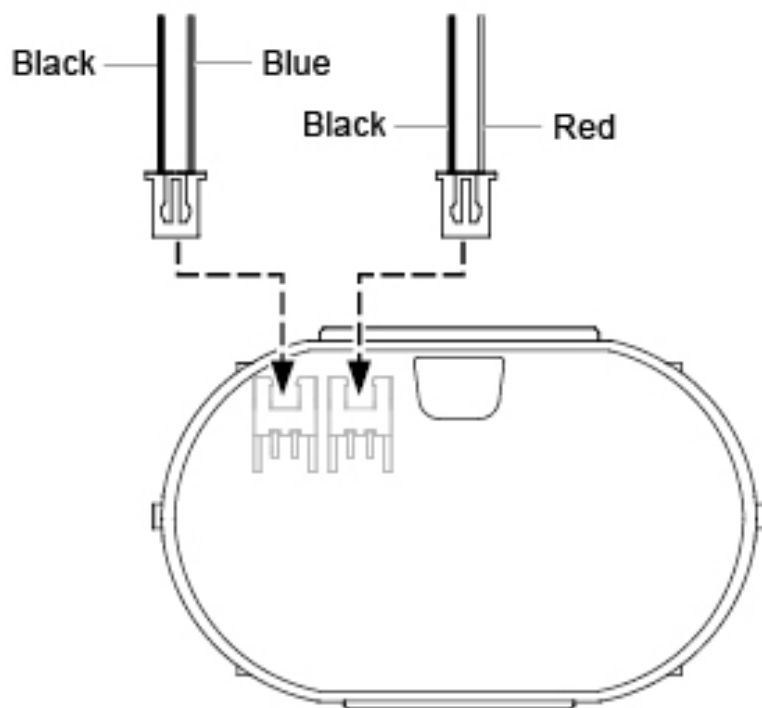

4. Do not play the Tobbie under direct sunlight or halogen lamp, it may cause the robot to go wrong direction.
5. If Tobbie emitted a sound " Bee Bee Bee " while playing, it is on " low-battery " alert.
Replace new battery once it is exhausted.
6. Under " Explore " mode, if gearbox is still working but Tobbie does not move and
come with abnormal sound " Da Da Da ".
 - ① Refer to page 21, step **20**, check and ensure A19 is Installed correctly.
 - ② Refer to page 6, step **8**, check and ensure A15 is removed.
 - ③ Refer to page 6, step **7**, check and ensure all screws are fastened tightly.
7. If Tobbie is walking unstably or tumbling, check if A1(refer to page 18, step **16**) &
A2 (refer to page 22, step **22**) are not mixed, ensure both parts are installed correctly.

Tobbie

The Robot



- Removal and replacement of batteries should be carried out by adult or under adult supervision.
- Avoid short circuiting the contacts in the battery compartment or the battery terminals.
- Remove exhausted batteries from the product to avoid leakage.
- Do not mix used batteries and new batteries or batteries of different types.
- Do not mix alkaline, standard (carbon-zinc) , or rechargeable (nickel-cadmium) batteries.
- Batteries are to be inserted with the correct polarity.
- Do not attempt to recharge non-rechargeable batteries.
- Rechargeable batteries are only to be charged under adult supervision.
- Rechargeable batteries are to be removed from the toy before being charged.



WARNING :
CHOKING HAZARD
Small parts
Not for children under
3 years

