

STAR TEAM

INSTRUCTION MANUAL LASER TAG

Key Functions

GUN

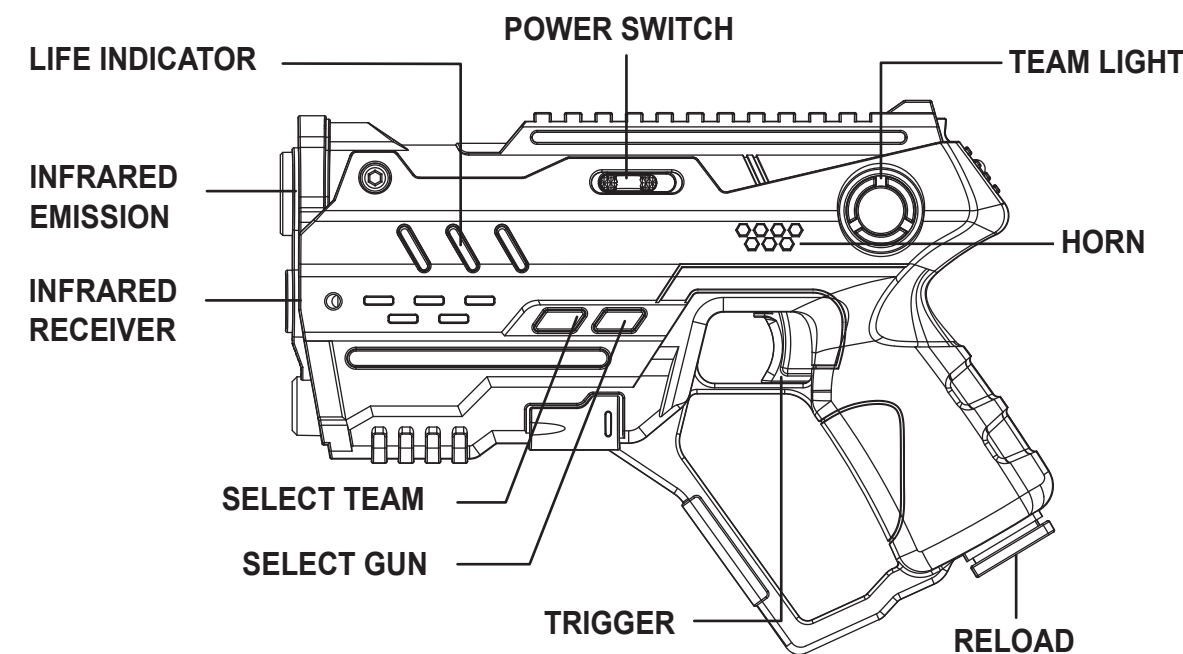

VEST

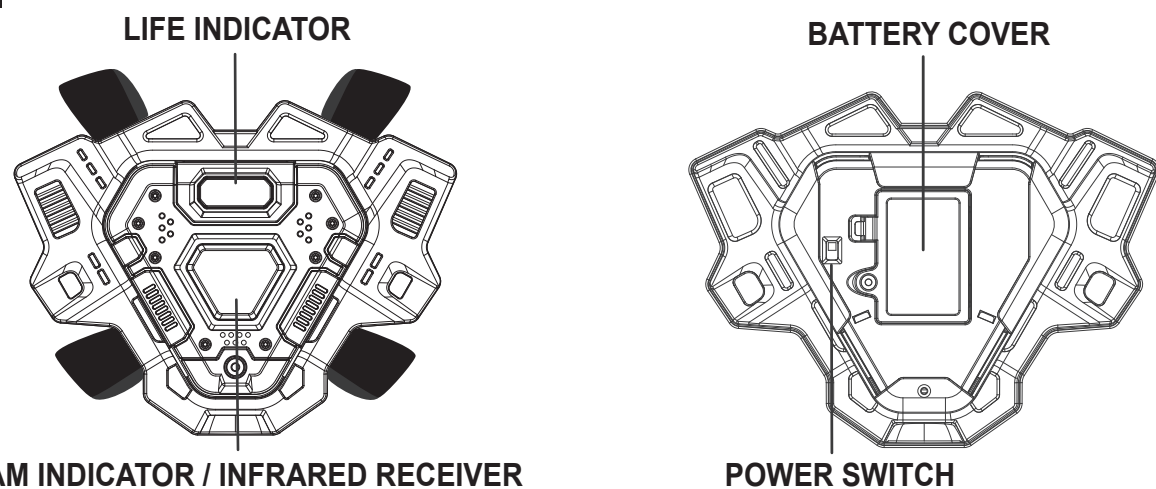

- LIFE INDICATORS: EACH LIFE INDICATOR REPRESENTS 3 HEALTH POINTS (FOR A TOTAL OF 9 OR 12)
- LOW BATTERY: ALL LIFE INDICATORS WILL FLASH SLOWLY TO INDICATE THAT THE GUN / VEST HAS LOW BATTERY
- MAX SHOOTING RANGE: 40M

BATTERY INSTALLATION

GUN

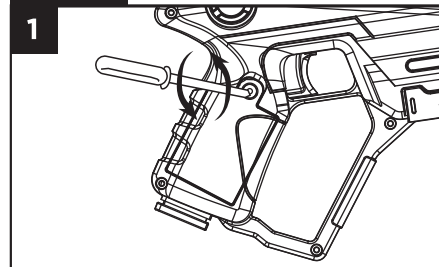

Use a screwdriver to remove the battery cover

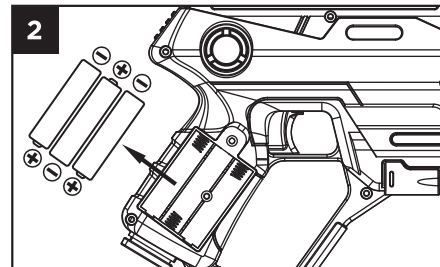

Insert 3 AAA batteries(not included). Make sure the batteries are inserted with the correct polarity.

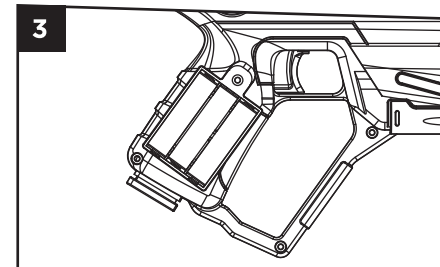

Replace the battery cover.

VEST

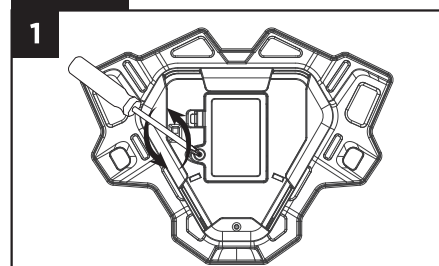

Use a screwdriver to remove the battery cover

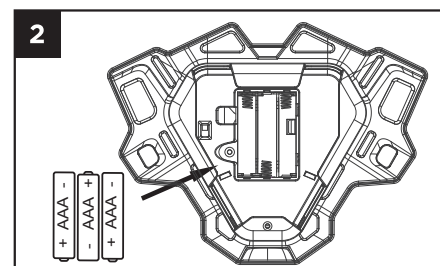

Insert 3 AAA batteries(not included). Make sure the batteries are inserted with the correct polarity.

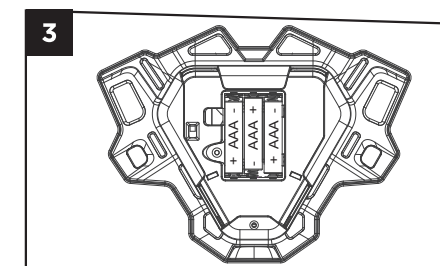

Replace the battery cover.

SAFETY AND WARNING INFORMATION

Do not mix alkaline standard (carbon zinc) and rechargeable (nickel hydride) batteries.

Do not mix old and new batteries.

Non-rechargeable batteries should not be charged.

Rechargeable batteries should be charged under adult supervision only.

Exhausted batteries should be removed.

Batteries should be inserted with the correct polarity.

The supply terminal should not be short-circuited.

Do not put batteries next to or in a heat source (fire, electronic heating device, etc.)

Do not hit guns and vests against hard objects.

Do not expose any parts of the set to water or other moisture.

Caution: use of controls or adjustments or performance of procedures other than those specified herein may result in hazardous radiation exposure.

VEST INSTRUCTION

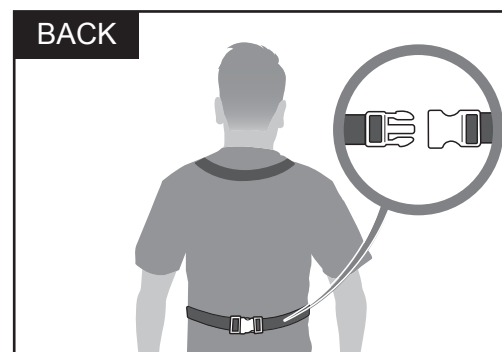
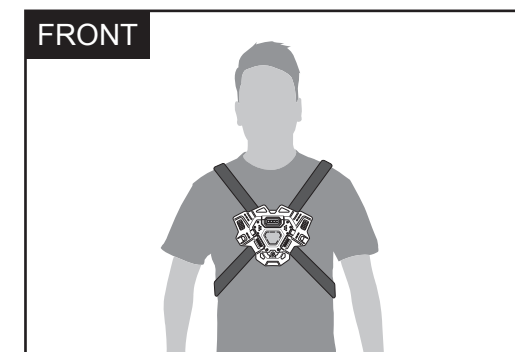

1. Place vest strap over your neck.
2. Fasten buckle in the back. Tighten straps to secure vest.

OPERATION INSTRUCTION

1 Switch the gun on(It will play the start sound and team light will flash different color). The gun will default to Single shot.

2 Team selection of gun: Press the team selection button to toggle between teams. There are 4 colors to represent possible teams – blue, red, green or white. You cannot shoot your own team. A player cannot change teams during a game.

3 Switch the vest on and it will cycle through different colors. Use the gun to shoot the vest with 1 shot and the vest will turn the color of your team. The vest is now assigned to your team. See pairing diagram on the right.

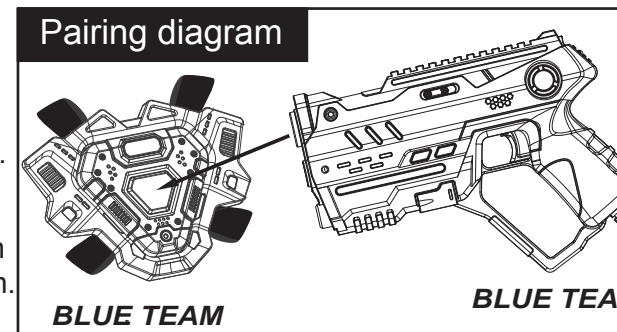

4 Gun modes and shots selection: Press button (FIRES) to toggle between 4 gun modes:

| Gun Modes | Single shot | Laser gun | Machine gun | Plasma gun |
|-----------------------------|-------------|-----------|-------------|------------|
| Shots | | | | |
| Health reduced by each shot | | | | |

When you run out of ammo,press the reload button under the grip to reload.

5 Aim and shoot at an opponent's gun or vest to register a hit. Once hit, the health points counter will reduce accordingly and the gun/vest will vibrate and emit a sound. Each life indicator will show a different level of health (See Health points counter diagram). Health points of the gun and the vest are calculated independently. Gun has 3 life indicators=9 health points, vest has 4 life indicators=12 health points. When all lives reaches 0, all indicators will be dark and then flash, you will be unable to fire anymore.

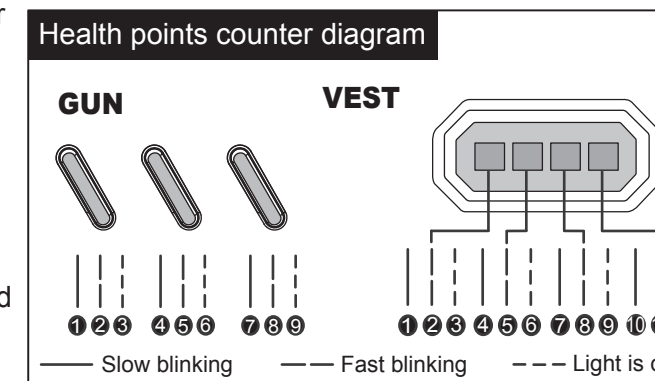

There are 2 ways to play (See below diagrams).

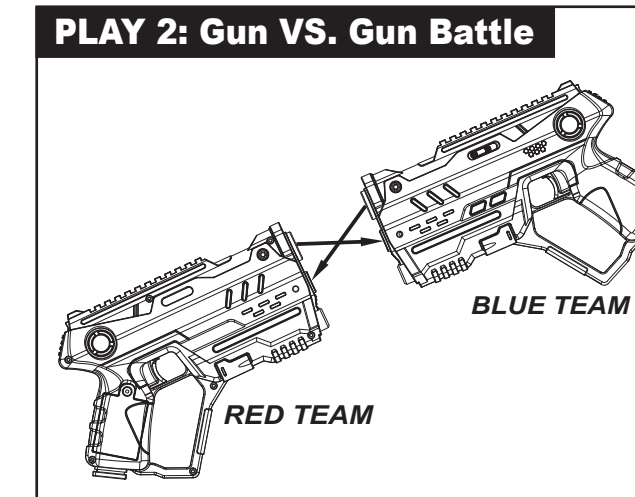
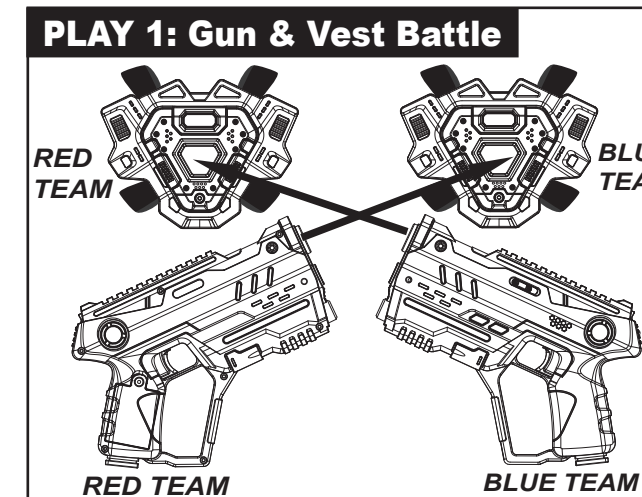

RESET GUN & VEST

- A player cannot change teams or reset a gun during a game.
- Press the team selection button to change your team before a game.
- To reset a gun/vest, switch the gun/vest off and on.

TROUBLE SHOOTING

| Problems | Possible reasons | Solutions |
|---------------------------|---|---|
| Products without function | The batteries are installed wrongly or they are damaged. | Reinstall the battery or change the battery. |
| | The switch is off. | Make sure the switch is on. |
| Failure to hit aims | Shot your teammates. | Try to shoot your opponents. |
| | The bullets haven't been added after shifting the gun type or they have been used up. | Press the " reload " button to reload the bullets. |
| | Failure to aim at opponents or it exceeds. | Aim at the targets, shorten the shooting distance. |
| Disable to use normally | Obstacles existing between two shooters. | Avoid obstacles. |
| | Low battery power, the life indicators flash at the same time. | Replace new batteries or charge(only for rechargeable batteries). |
| Shorter firing range | Affected by the other infrared devices (like TV remote control). | Don't use the other infrared devices when playing the toy. |
| | Using the laser tag in strong sunlight. | Block sunlight or play in an area without strong sunlight. |

WARRANTY

Our product is guaranteed to be free from manufacturing defects for a period of 12 Months. If your product becomes defective during this period, Electus Distribution will repair, replace, or refund where a product is faulty; or not fit for intended purpose. This warranty will not cover modified product; misuse or abuse of the product contrary to user instructions or packaging label; change of mind and normal wear and tear. Our goods come with guarantees that cannot be excluded under the Australian Consumer Law. You are entitled to a replacement or refund for a major failure and for compensation for any other reasonably foreseeable loss or damage. You are also entitled to have the goods repaired or replaced if the goods fail to be of acceptable quality and failure does not amount to a major failure. To claim warranty, please contact the place of purchase. You will need to show receipt or other proof of purchase. Additional information may be required to process your claim. Any expenses relating to the return of your product to the store will normally have to be paid by you. The benefits to the customer given by this warranty are in addition to other rights and remedies of the Australian Consumer Law in relation to the goods or services to which this warranty relates.

This warranty is provided by:
Electus Distribution | Address 46 Eastern Creek Drive, Eastern Creek NSW 2766 | Ph. 1300 738 555