

HEXBUG[®]

VEX[®]

ROBOTICS

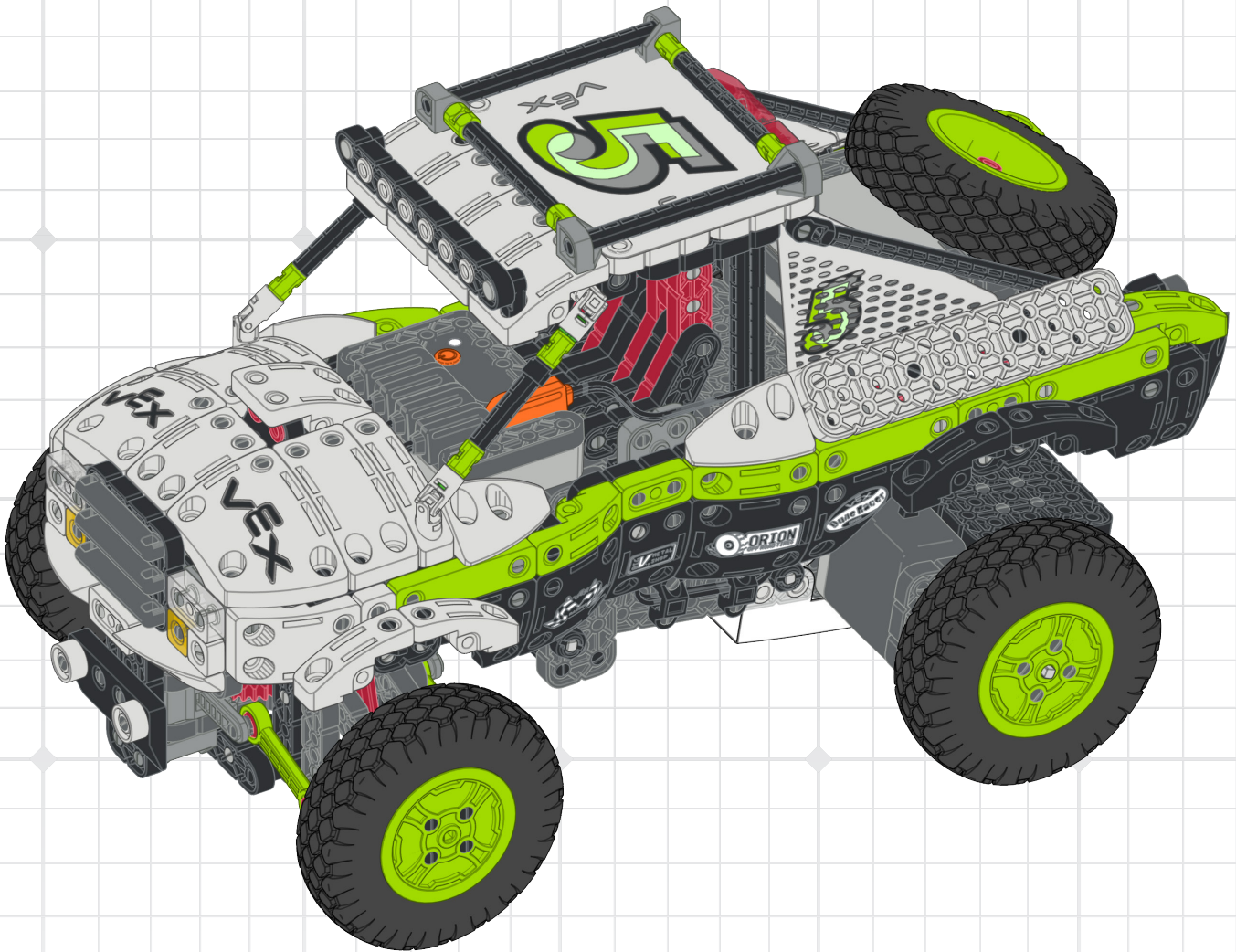

OFFROAD TRUCK[™]

COUNT BEFORE YOU CONNECT • CONTAR ANTES DE CONECTAR • COMPTER AVANT DE CONNECTER • CONTARE I PEZZI PRIMA DI COLLEGARLI • ERST ZÄHLEN, DANN VERBINDEN • POLICZ, ZANIM POŁĄCZYSZ • TELL VOORDAT U AANSLUIT

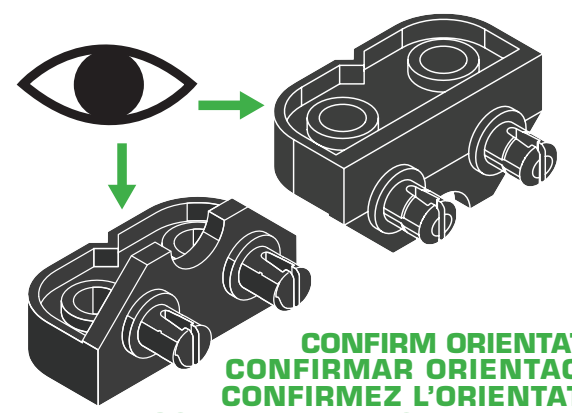
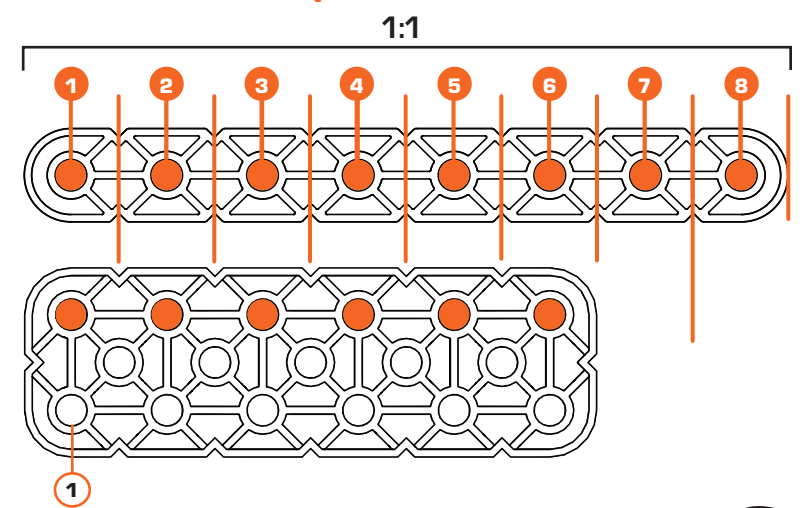

CONFIRM ORIENTATION
CONFIRMAR ORIENTACIÓN
CONFIRMEZ L'ORIENTATION
CONFERMARE L'ORIENTAMENTO
AUSRICHTUNG PRÜFEN
POTWIERDŹ ORIENTACJĘ
BEVESTIG ORIENTATIE

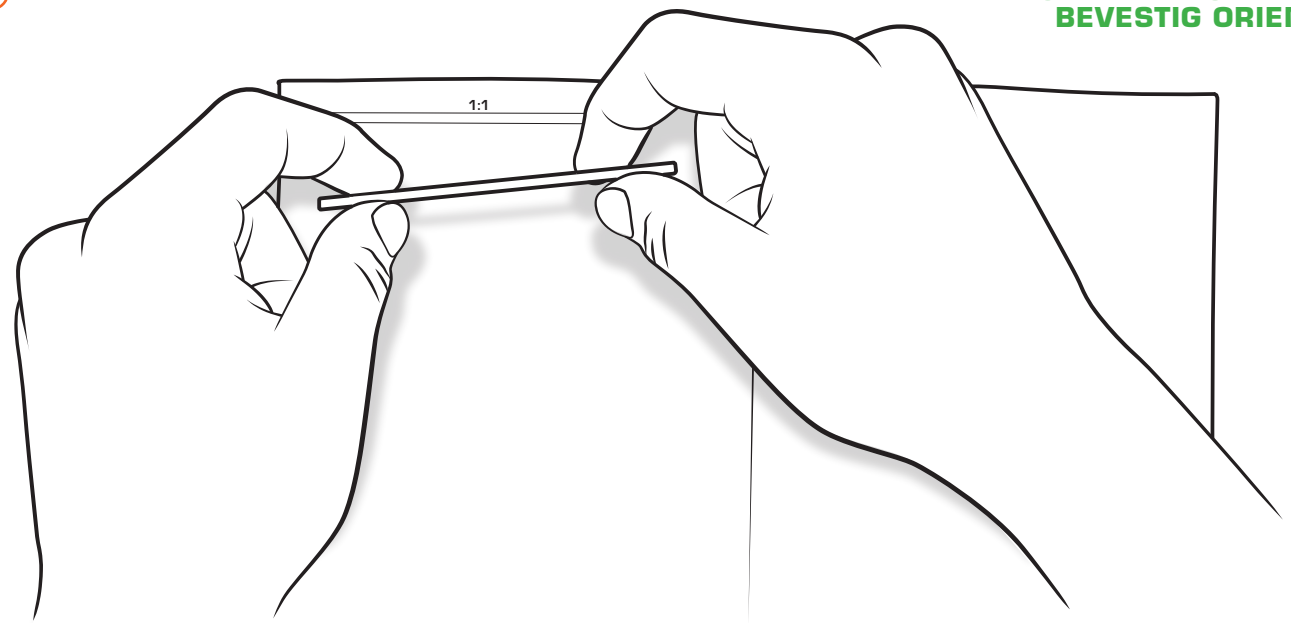

CHECK PIECES AGAINST ACTUAL SIZE IN MANUAL
PONEZ PEDAZOS CONTRA TAMANO REAL EN EL MANUAL
VERIFIEZ LES PIÈCES CONTRE LEURS TAILLES REELLES DANS LE MANUEL
CONTROLLARE LE DIMENSIONI DEI PEZZI NEL MANUALE RISPETTO ALLA GRANDEZZA NATURALE
BAUTEILE MIT DER ORIGINALGRÖÙE IN DER ANLEITUNG VERGLEICHEN
SPRAWDŹ ELEMENTY WZGLĘDEM RZECZYWISTEGO ROZMIARU W INSTRUKCJI
CHECK STUKKEN TEGEN DE WERKELIJKE GROOTTE IN DE HANDMATIGE

| | | | | | |
|---|---|--|--|---|---|
| | | | | | |
| ALERT ALERTA ALERTE ATTENZIONE WARNUNG OSTRZEŻENIE WAAKSCHUWING | CORRECT CORRECTO CORRECTE CORRETTO RICHTIG PRAWIDŁOWO CORRECT | FLIP BOLTIAR RETOURNER CAPOVOLGERE UMDREHEN PRZERZUĆ OMDRAAIEN | INCORRECT INCORRECTO INCORRECTE NON CORRETTO FALSCH NIEPRAWIDŁOWO VERKEERD | ALTERNATE VIEW VISTA ALTERNATIVA AUTRE VUE VISTA ALTERNATIVA ANDERE ANSICHT WIDOK ALTERNATYWNY VITZICHT | STICKER CALCOMANIA AUTOCOLLANT ETICHETTA AUFKLEBER NAKLEJKA STICKER |

REMOVE CONNECTORS
QUITAR CONECTORES
RETIREZ CONNECTEURS
RIMUOVERE I CONNETTORI
VERBINDUNGSTÜCKE ENT- FERNEN
WYJMIJ ŁĄCZNIKI
VERWIJDER CONNECTORS

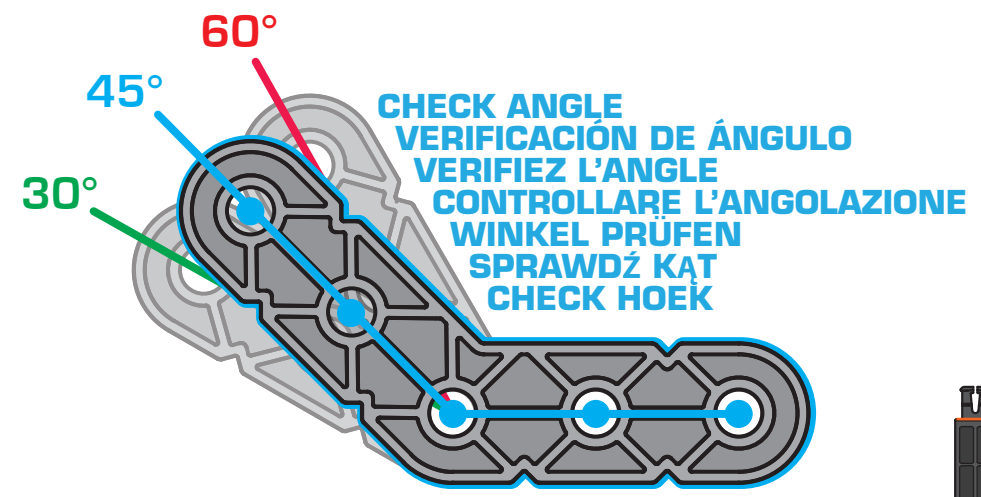
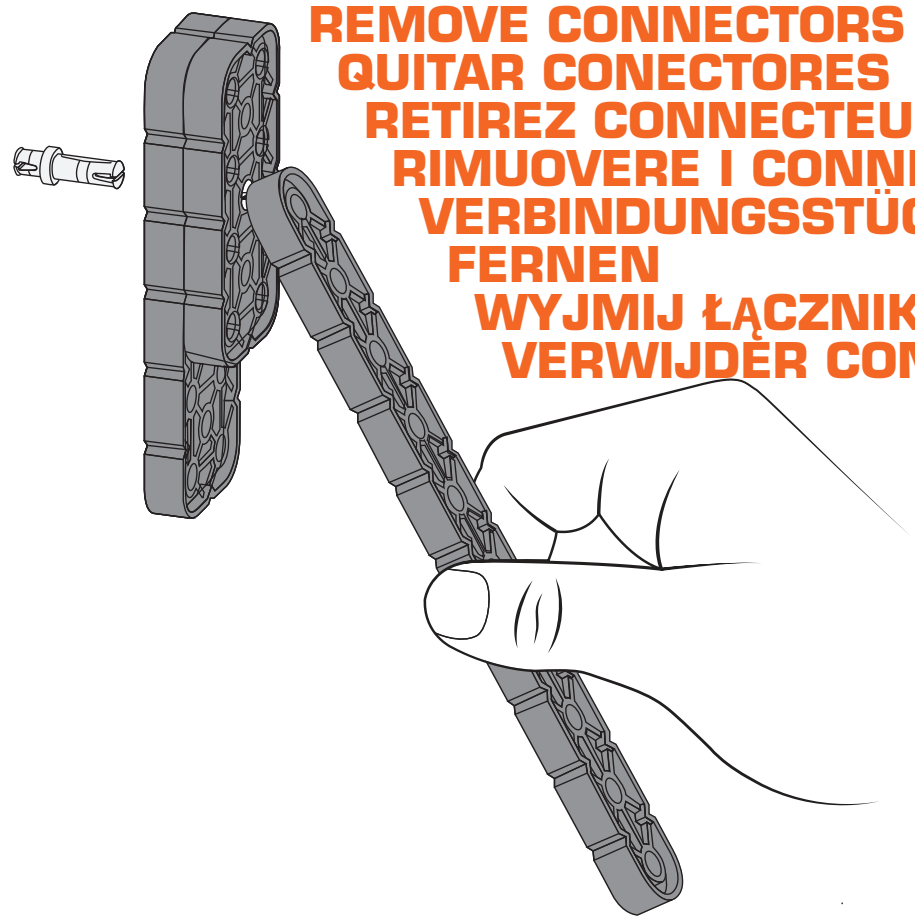

| | | |
|--|---|---|
| | | |
| NOTICE AVISO AVIS FARE ATTENZIONE HINWEIS ZWRÓĆ UWAGĘ OPMERKEN | ROTATE GIRAR FAIRE TOURNER RUOTARE DREHEN OBRÓĆ DRAAIEN | WIND UP DAR CUERDA LIQUIDER ARROTOLA AUFZIEHEN NAWIŃ OPWINDEN |

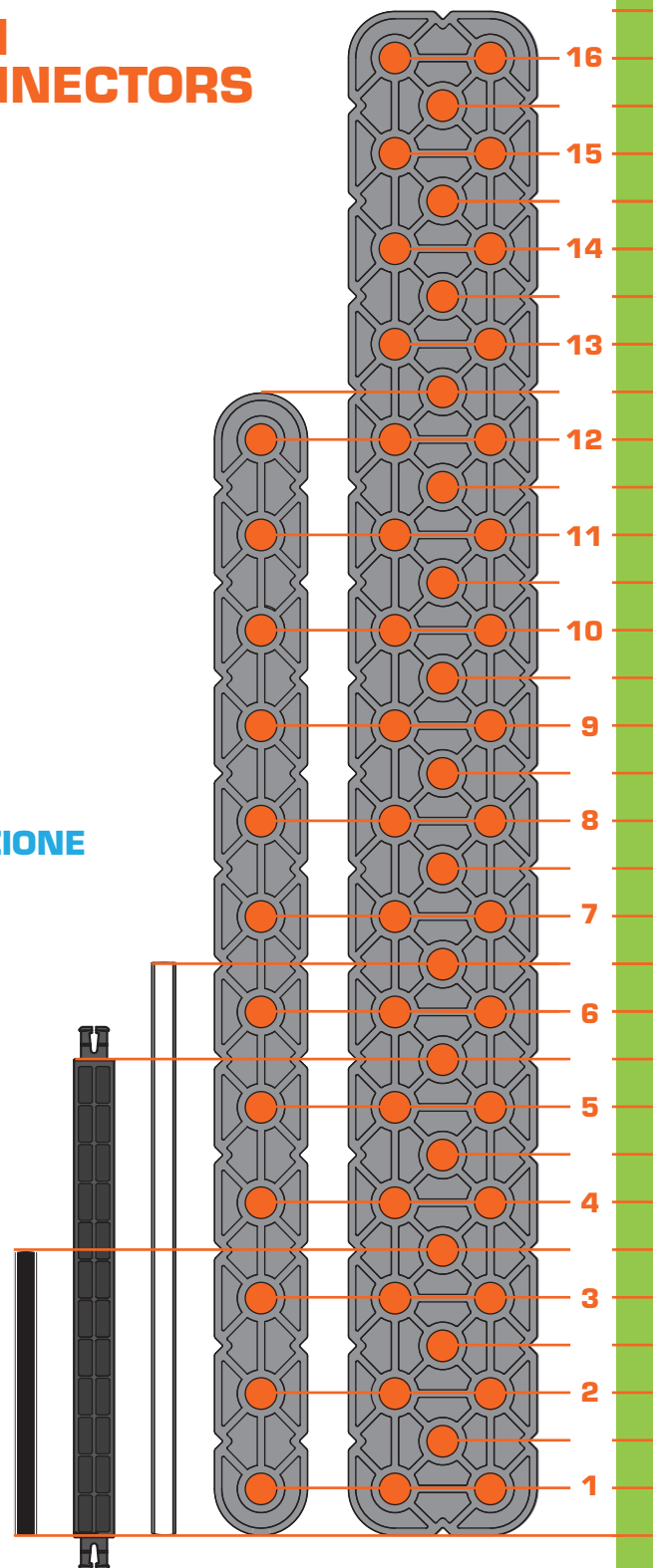

PARTS/ PARTES/ LES PIÈCES/ BAUTEILE/ PARTI/

CZESCI/ ONDERDELEN

- 2x 228-3201-510
- 6x 228-3616-145
- 4x 228-3201-150
- 4x 228-3201-158
- 6x 228-3201-149
- 4x 228-4133-147
- 10x 228-3943-154
- 2x 228-4143-1727
- 2x 228-4143-1728
- 2x 228-4133-001
- 5x 228-3616-001
- 3x 228-3943-2121
- 3x 228-3201-032
- 6x 228-5579-513
- 16x 228-3616-003
- 2x 228-3201-003
- 2x 228-3201-005
- 1x 228-3201-007
- 1x 228-3201-1704

- 2x 228-3943-510
- 3x 228-3201-040
- 2x 228-4146-510
- 3x 228-3616-034
- 2x 228-3943-042
- 2x 228-3201-511
- 3x 228-3943-511
- 4x 228-5579-511
- 2x 228-4138-511
- 1x 228-3201-2121
- 6x 228-5579-2100
- 6x 228-3201-019
- 1x 228-3201-020
- 3x 228-3616-021
- 3x 228-3616-023
- 2x 228-3943-035

- 4x 228-3201-2116
- 8x 228-3943-2101
- 2x 228-3201-2101
- 1x 406-4557-001
- 3x 228-3943-2120
- 2x 228-3943-2108
- 2x 228-3943-2109
- 1x 228-3201-2120
- 2x 228-3201-478
- 2x 228-3943-024
- 1x 228-3201-025
- 2x 228-3616-027
- 2x 228-3616-030
- 4x 228-3943-2100
- 3x 228-3944-135
- 2x 228-3944-274
- 7x 228-3201-277

- 3x 228-3201-2125
- 3x 228-3201-2124
- 1x 228-3943-2134
- 1x 406-4557-002
- 1x 406-4557-003
- 1x 228-3943-2135
- 2x20
- 6x 228-3201-2100
- 1x 406-4557-004
- 5x 228-3201-134
- 4x 228-3944-1255
- 4x 228-3944-1254

PARTS/ PARTES/ LES PIÈCES/ BAUTEILE/ PARTI/

CZESCI/ ONDERDELEN

6x 228-3201-172

251x 228-3616-060 **1x1**

68x 228-5573-061 **1x2** **2x2**

2x 228-3616-062

12x 228-3201-063 **0.25x**

18x 228-3944-064 **0.5x**

16x 228-3201-065 **1x**

4x 228-5579-084 **0x2**

2x 228-5573-086 **0x2**

6x 228-3616-087 **0x3**

2x 228-3944-066 **1.5x**

2x 228-3201-067 **2x**

2x 228-3201-069 **3x**

4x 228-3201-070 **4x**

6x 228-3201-072 **6x**

2x 228-3201-1061

23x 228-5579-170

2x 228-4133-099

14x 228-3201-109

2x 228-3201-1250

29x 228-3943-099

4x 228-3201-270

1x 228-3616-371

1x 228-3616-372

6x 228-3944-127

8x 228-4133-192

3x 228-3616-314

1x 228-3201-220

22x 228-3201-128



14x 228-3201-114

4x 228-5581-073 **1x1**

19x 228-2500-143 **3x**

1x 228-3201-081 **3.5x**

1x 228-5581-094

2x 228-3944-1456 **5x**

4x 228-2500-121 **6x**

1x 228-2500-122 **8x**

2x 228-2500-124

4x 228-3943-350

5x 228-5579-1953

5x 228-3201-1955



6x 228-3944-112

3x 228-4133-1925

2x 228-3944-1472

1x 228-5579-347

4x 228-3944-1469

3x 228-4133-463

2x 406-4557-1580

1x 228-3944-227

1x 228-4133-214

5x 406-4557-1480

8x 228-4133-1660

4x 228-5579-1665



1x 406-3368

1x 406-3375

1x 406-3370

3x 406-3372

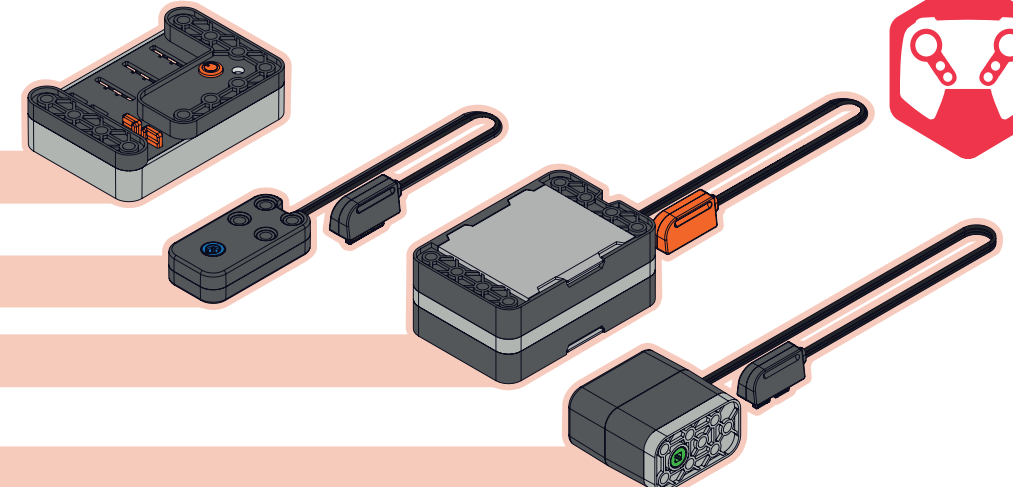

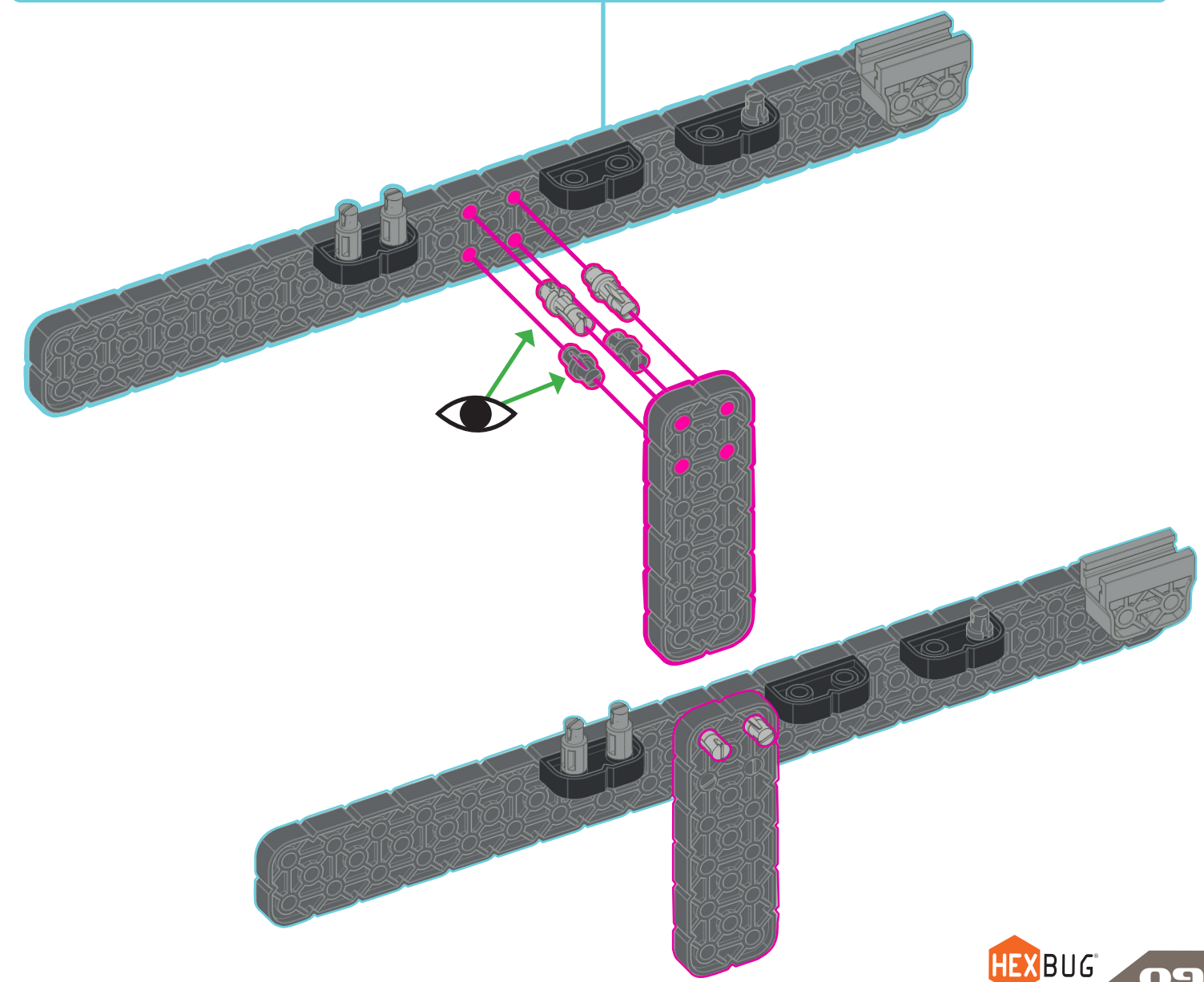
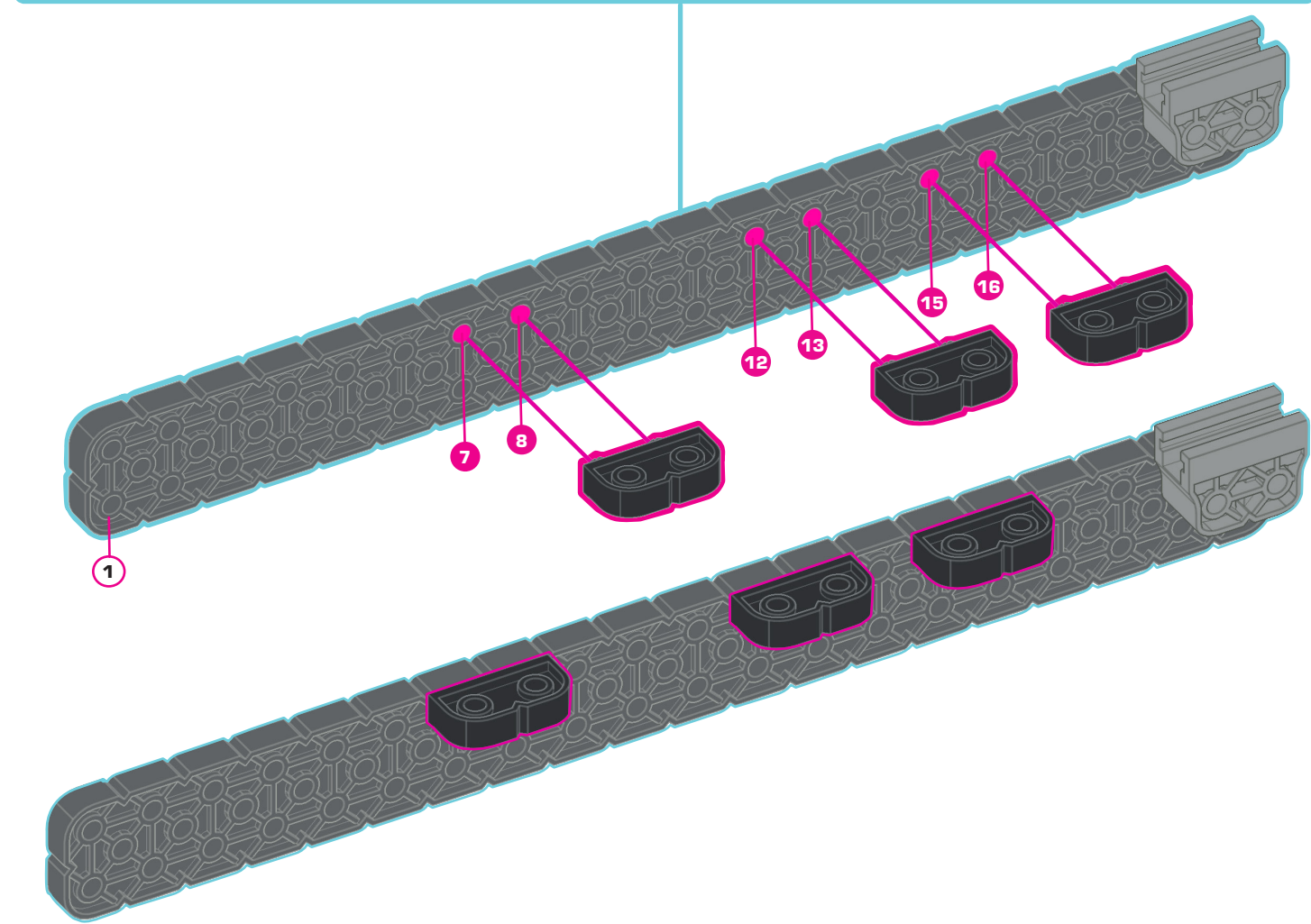
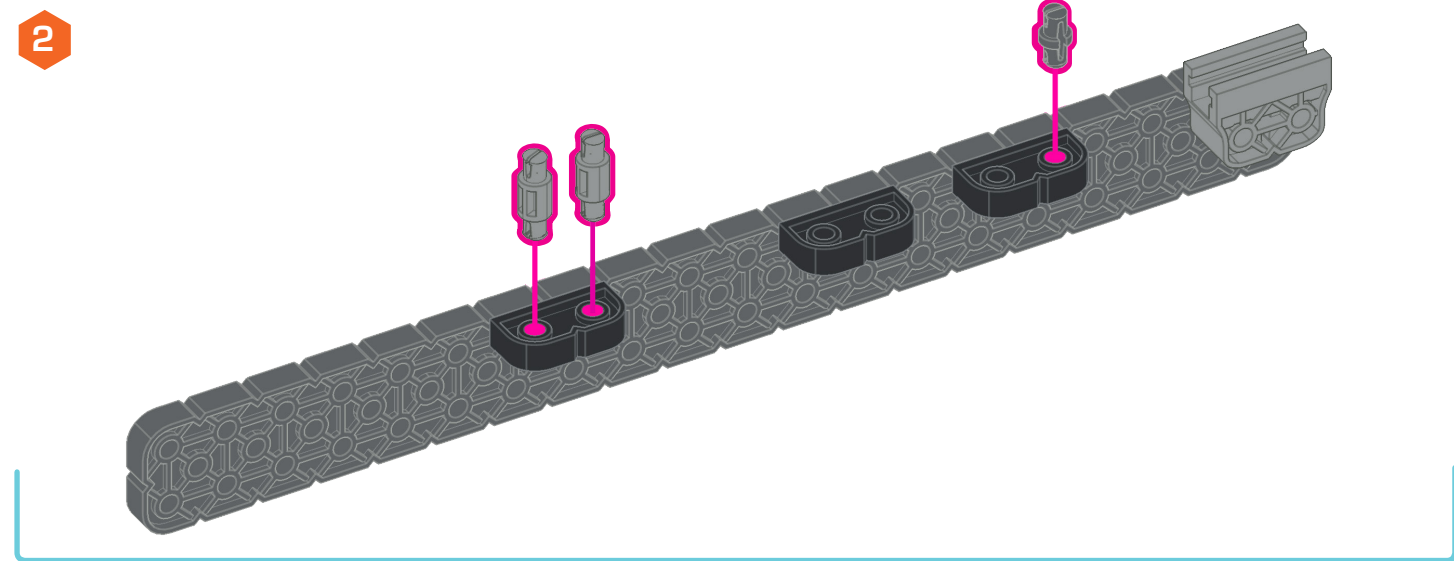
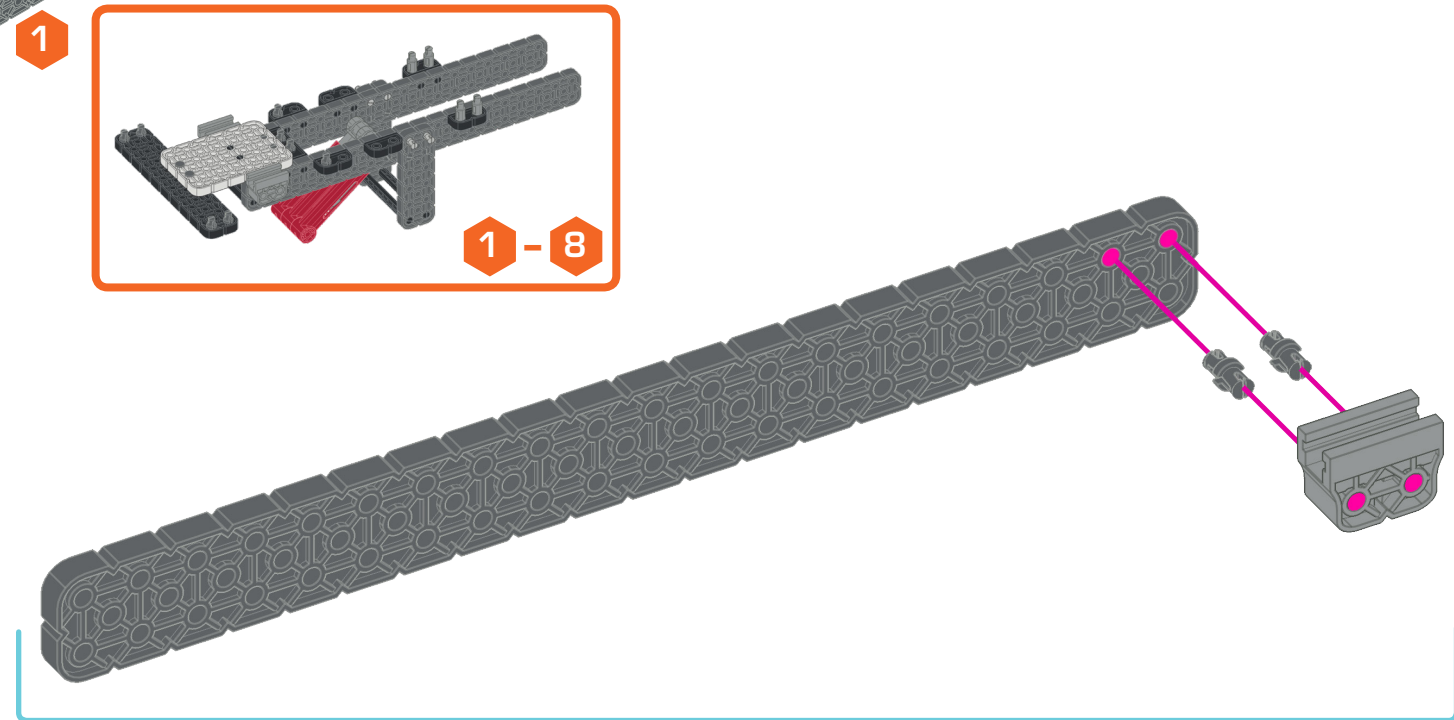
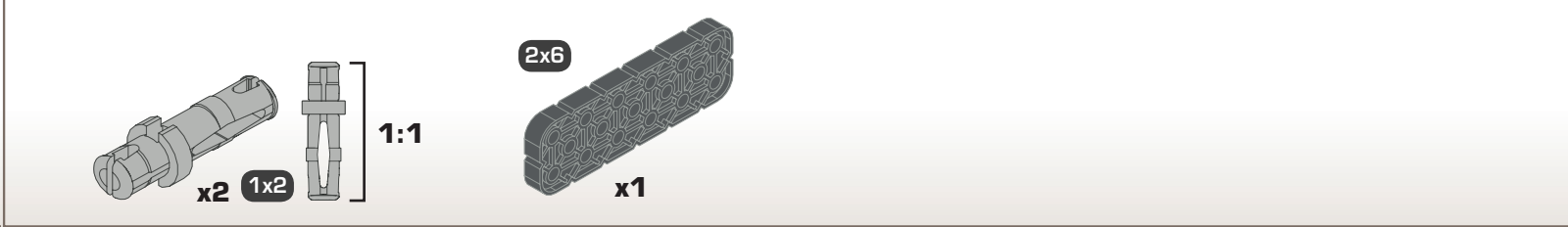
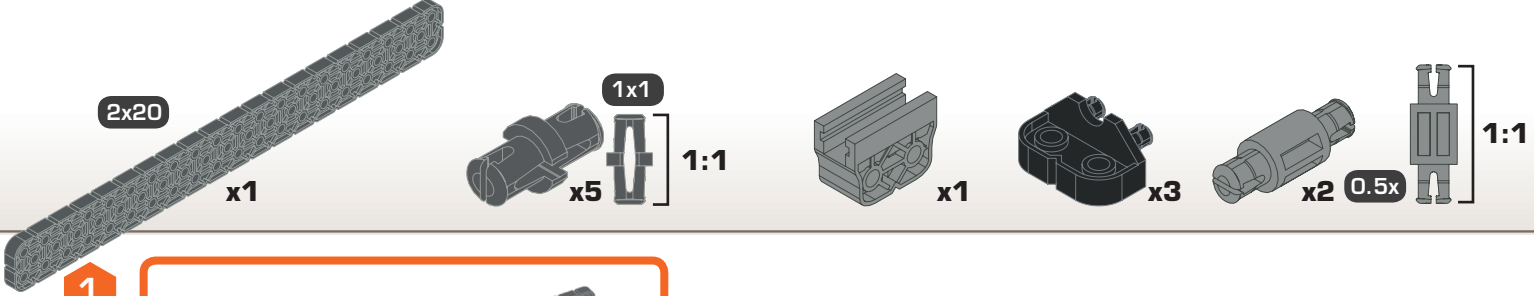

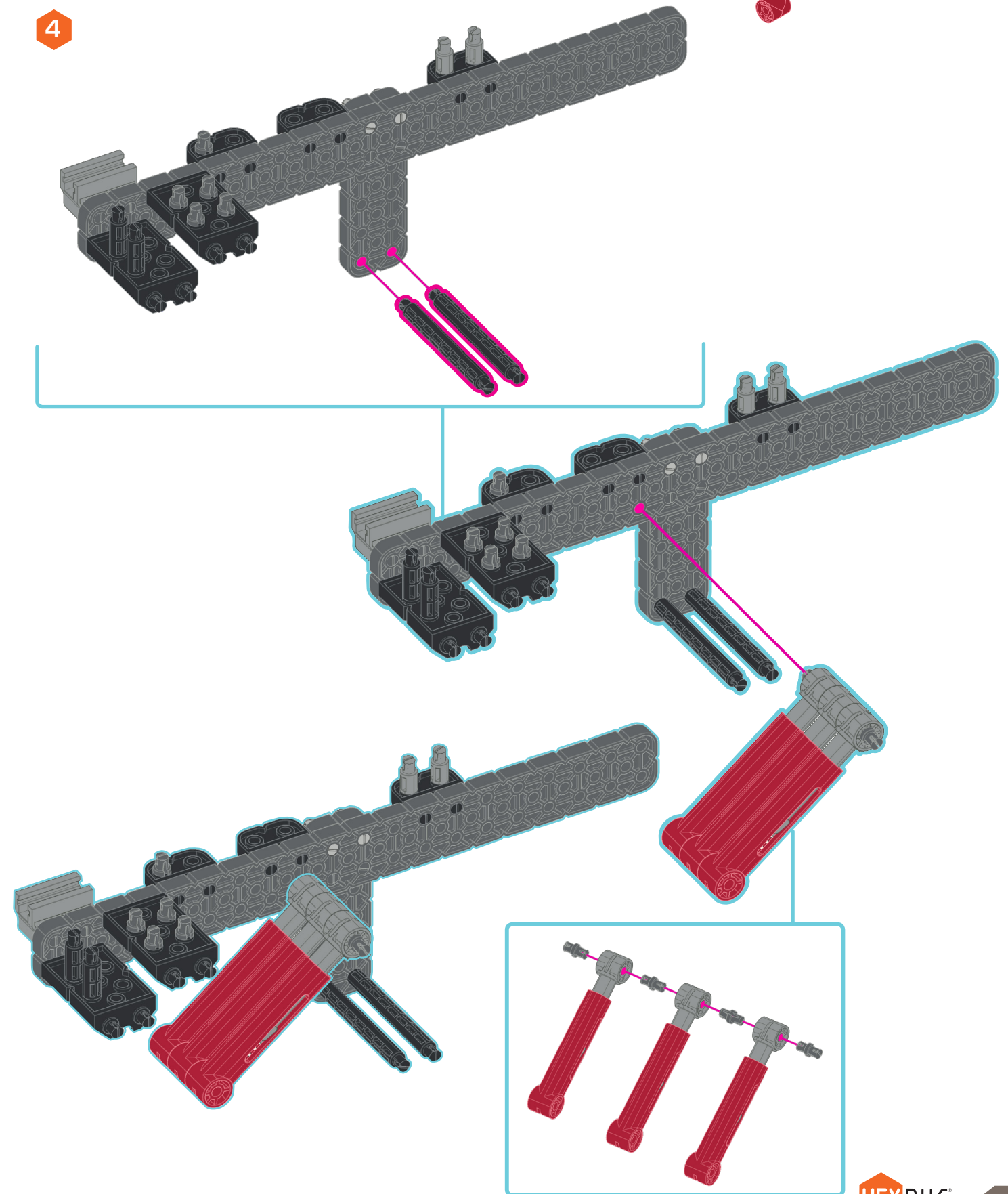
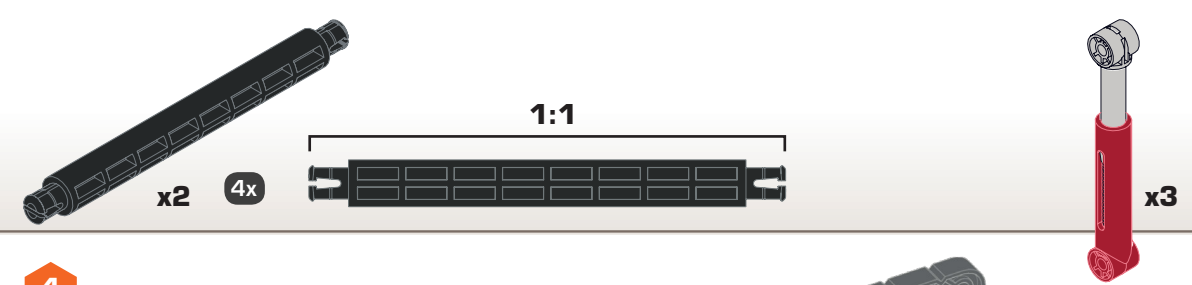
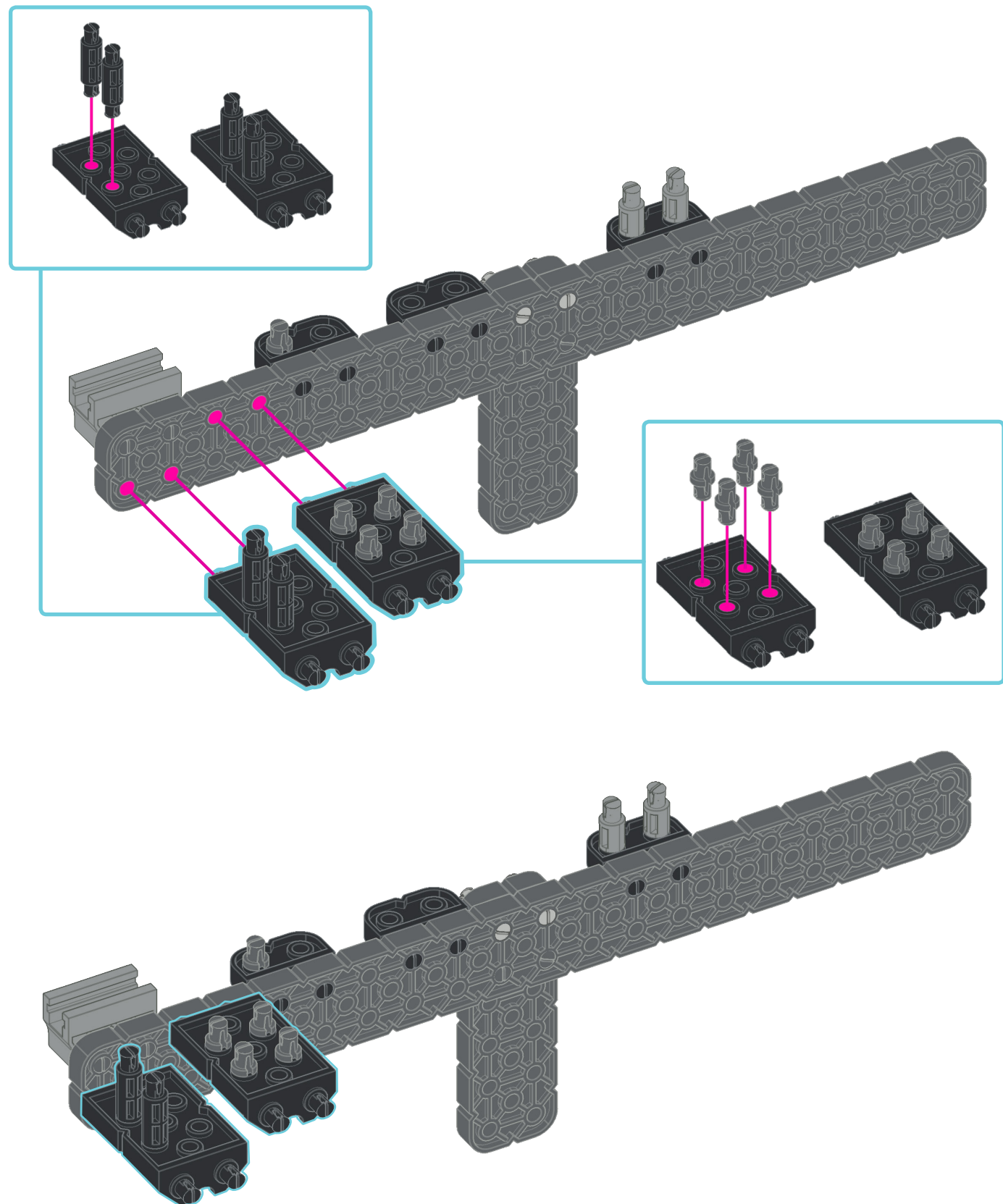
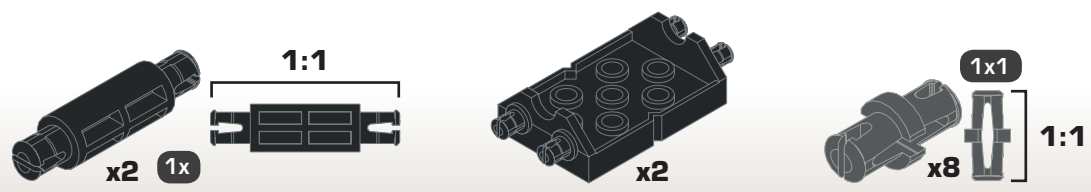

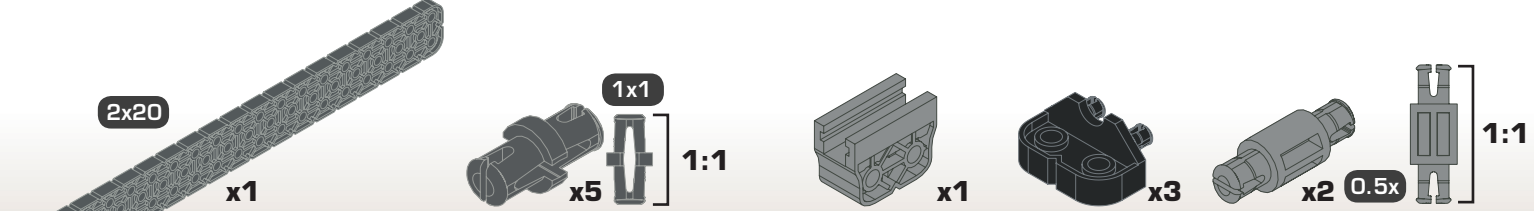

5

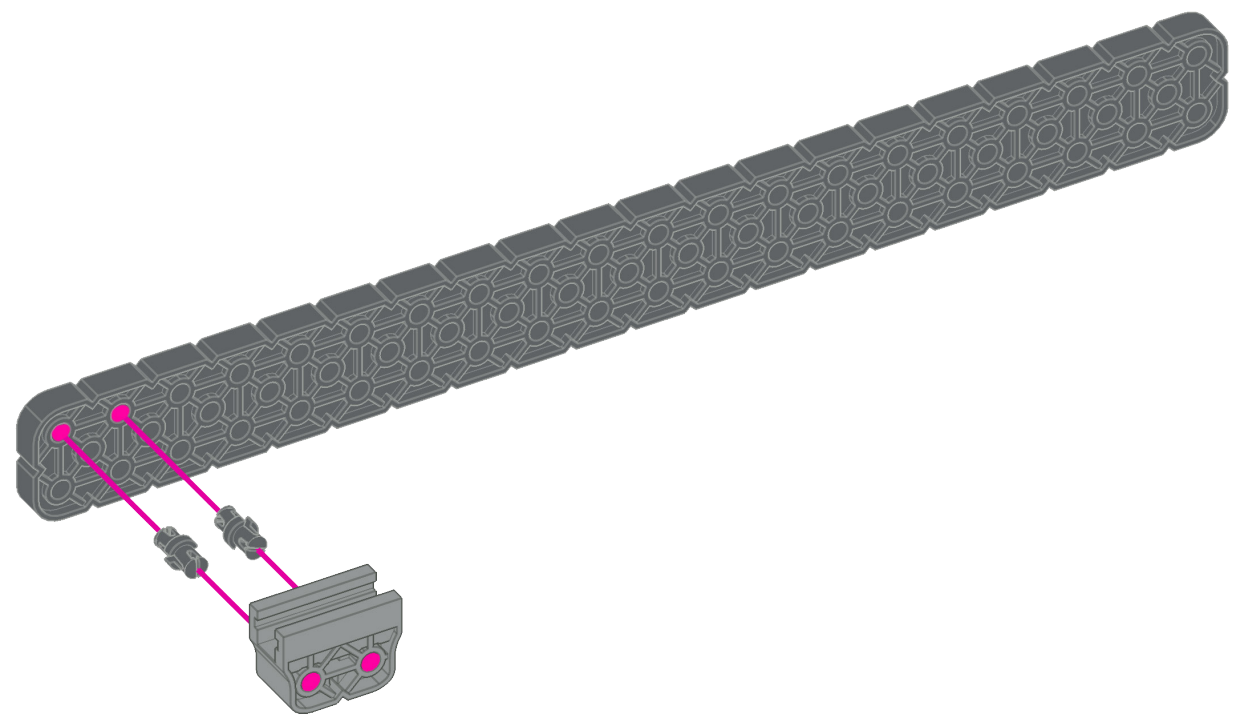

6

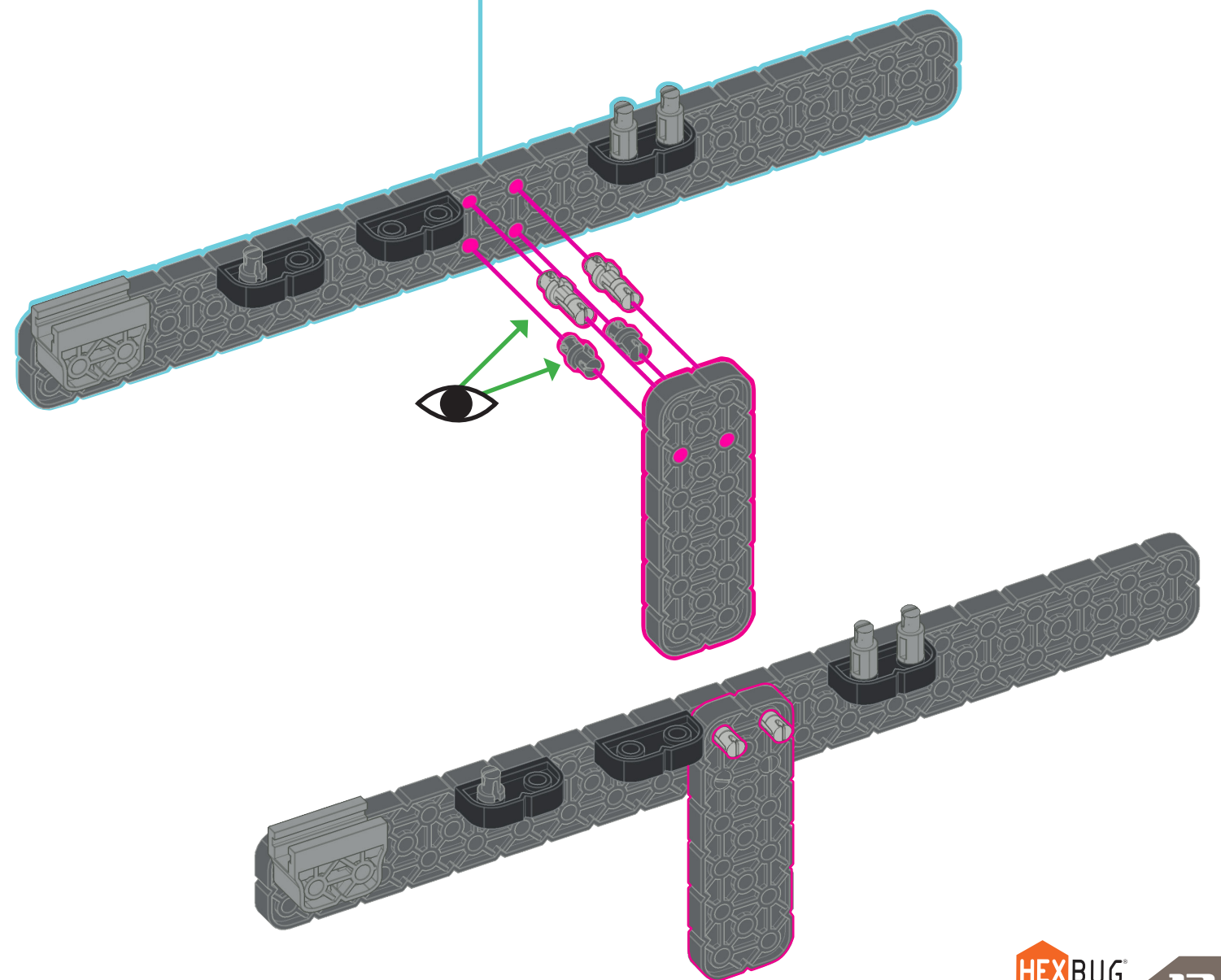
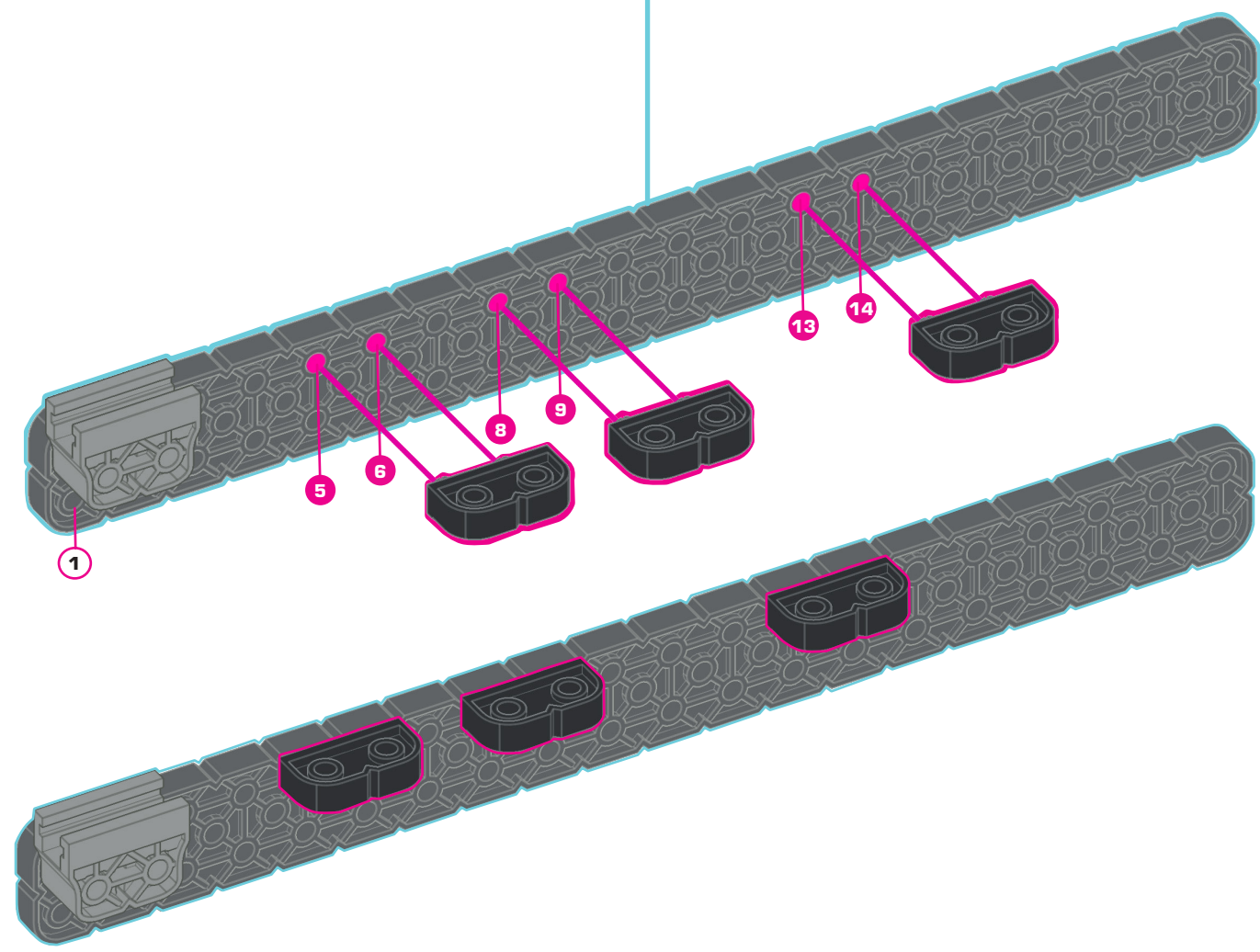
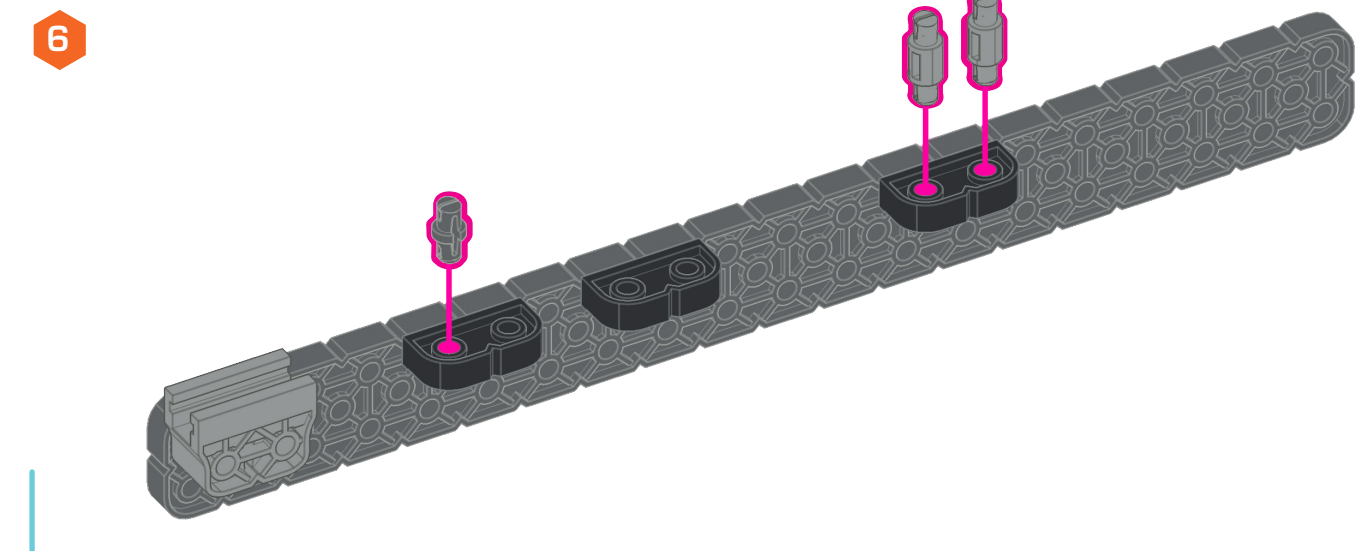
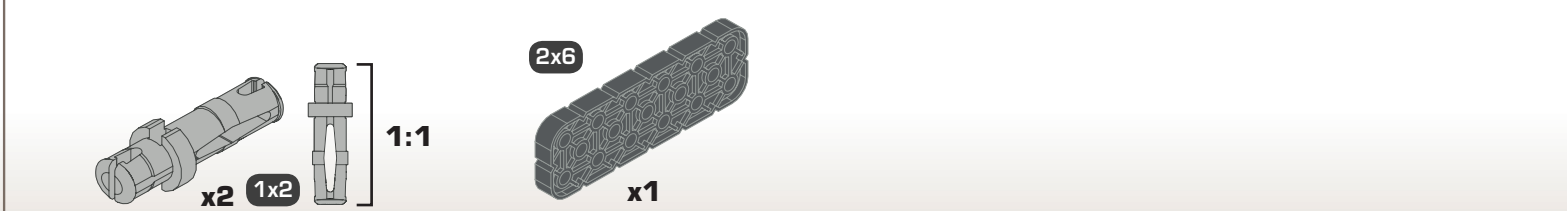

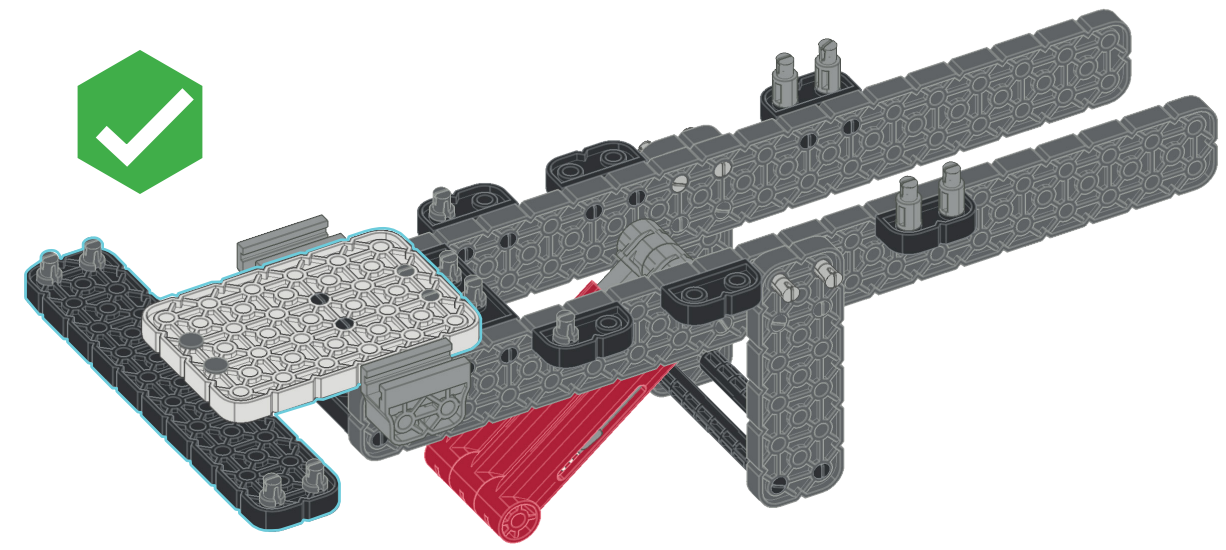
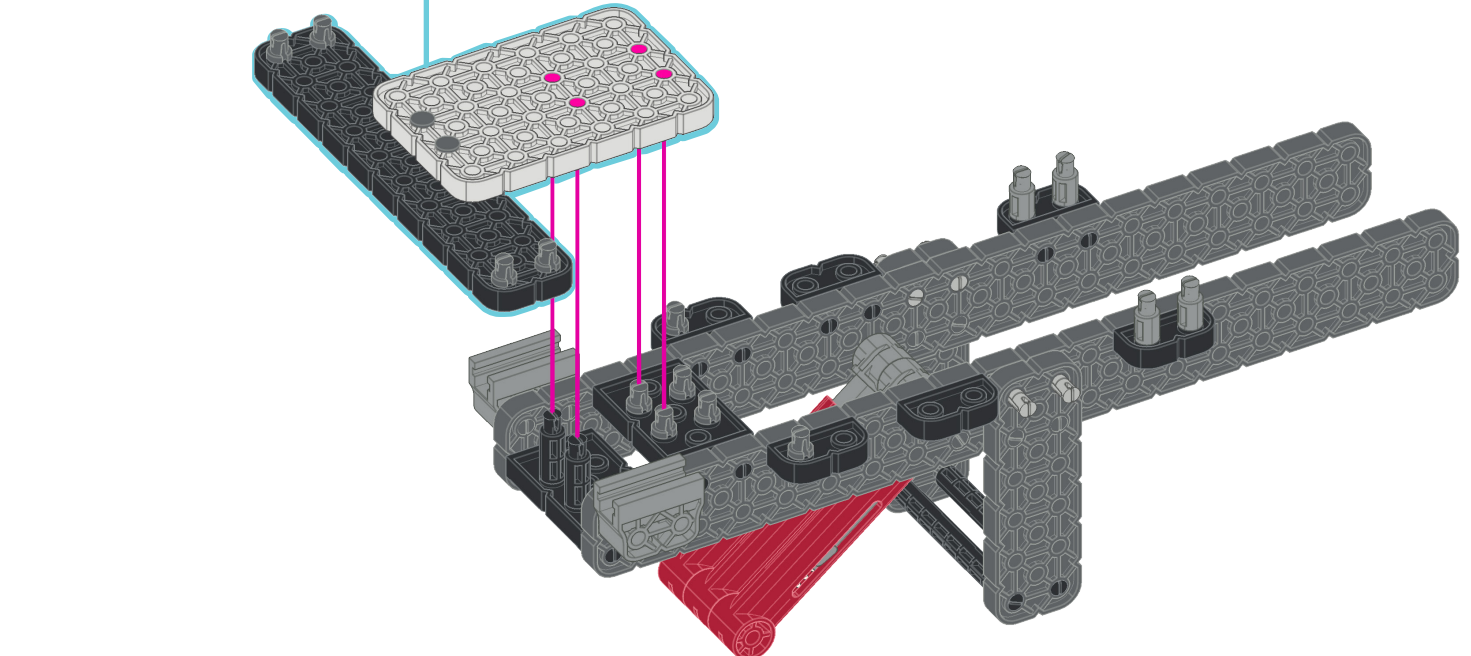
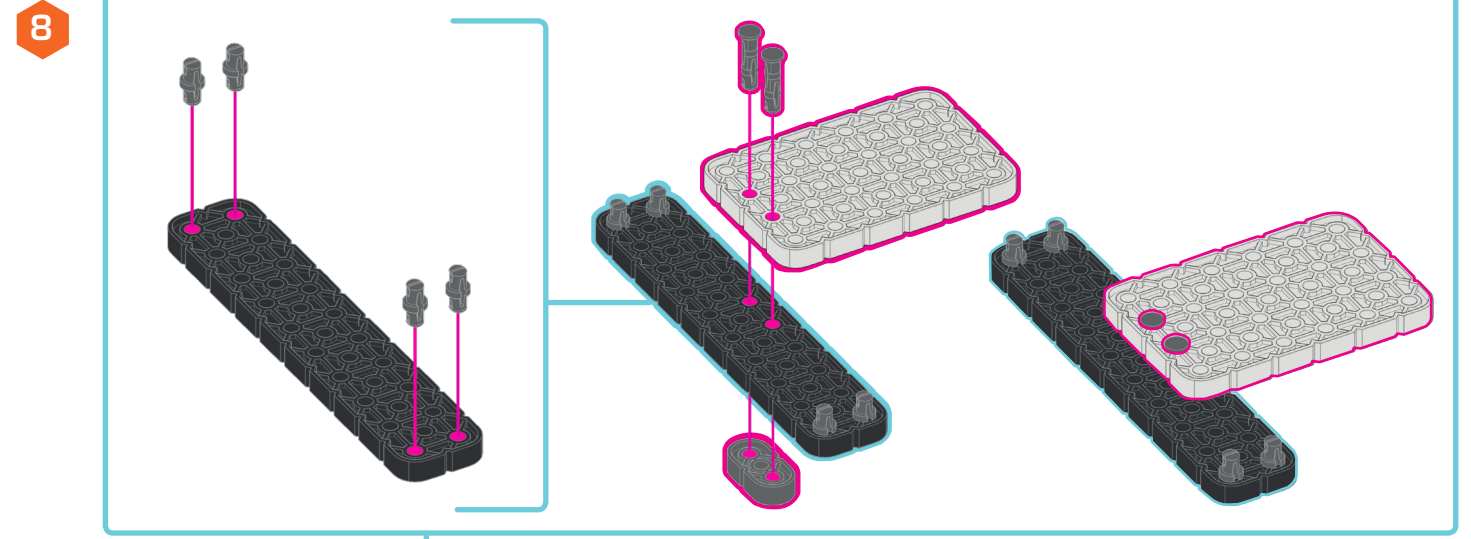
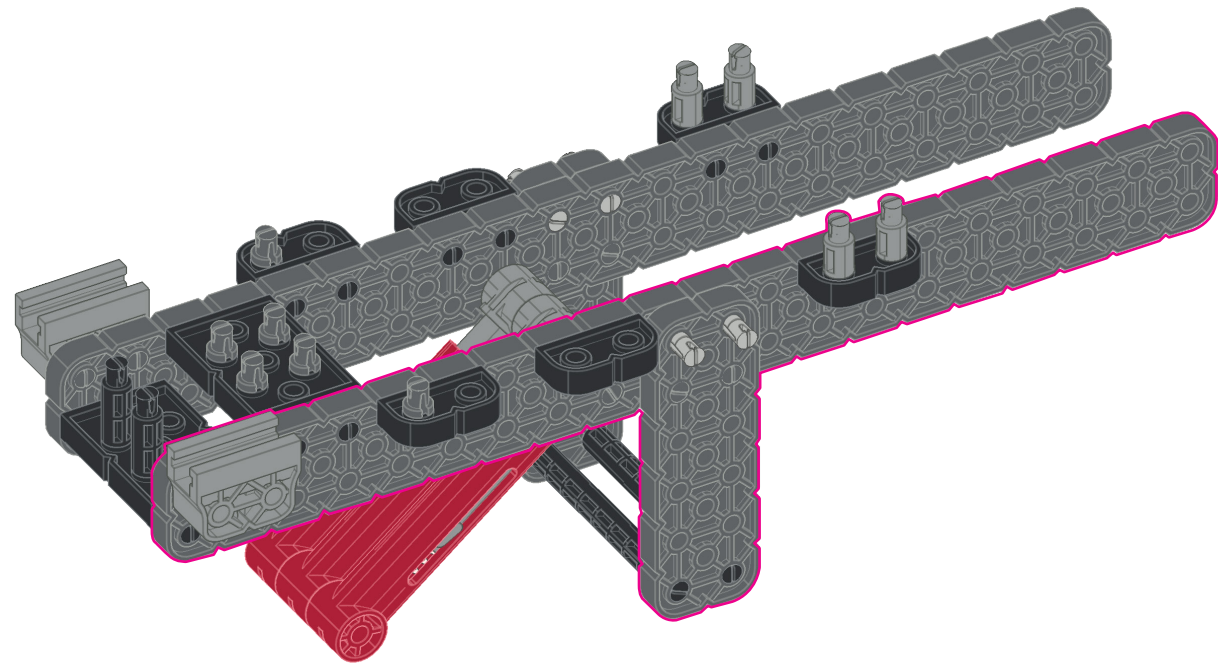
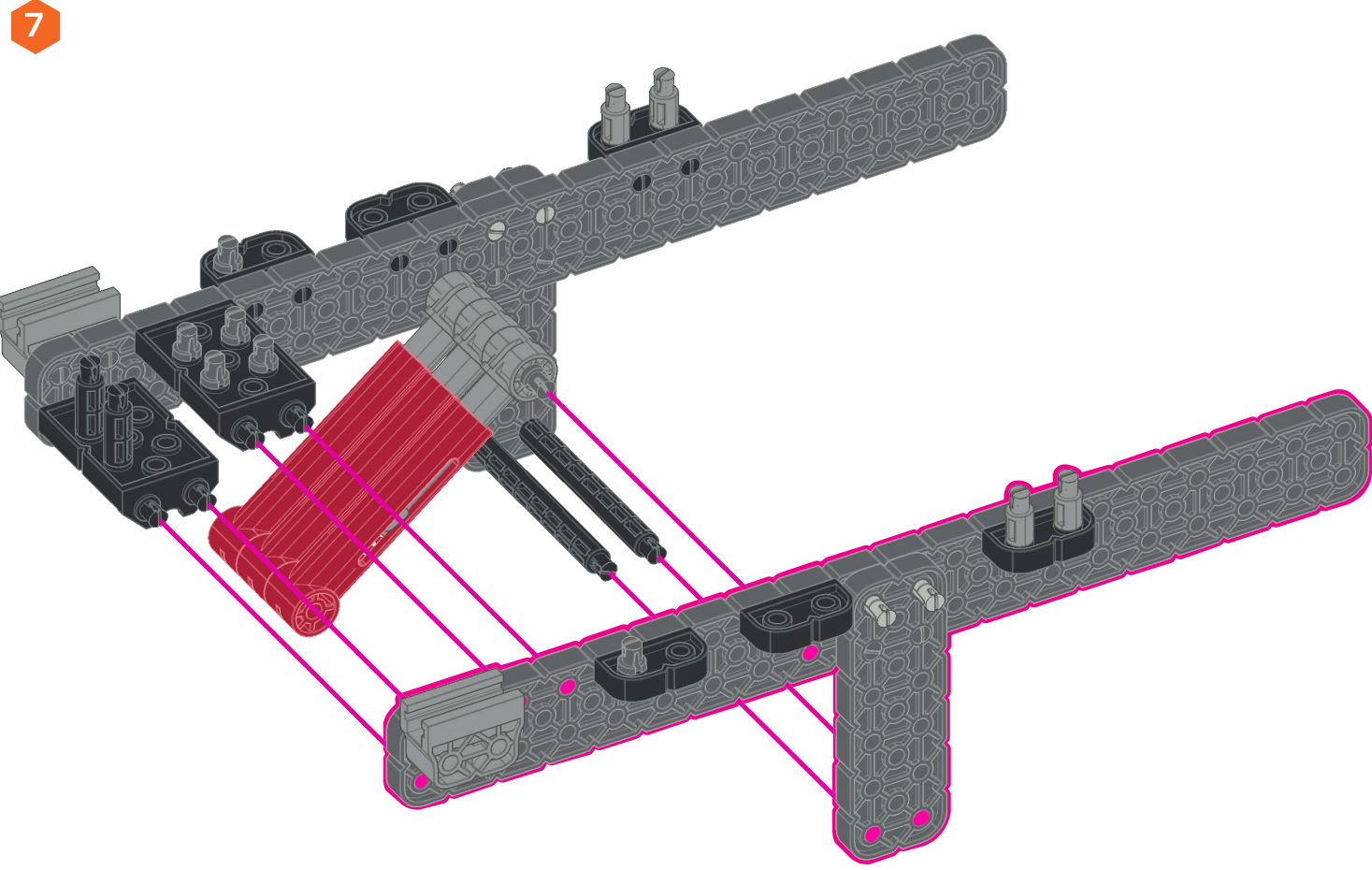
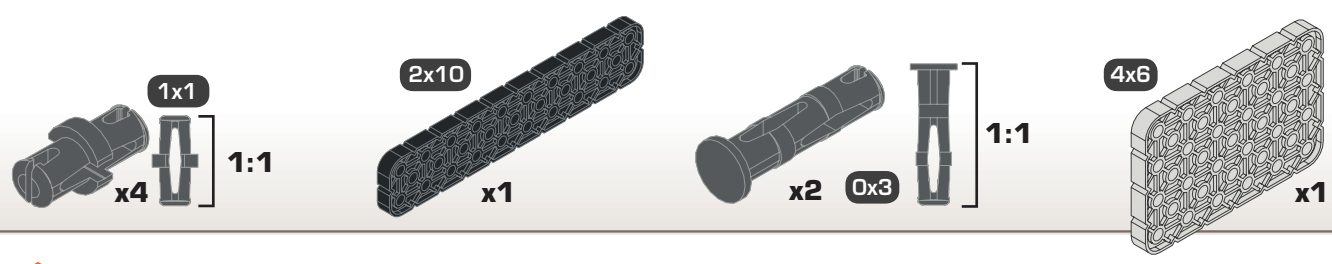

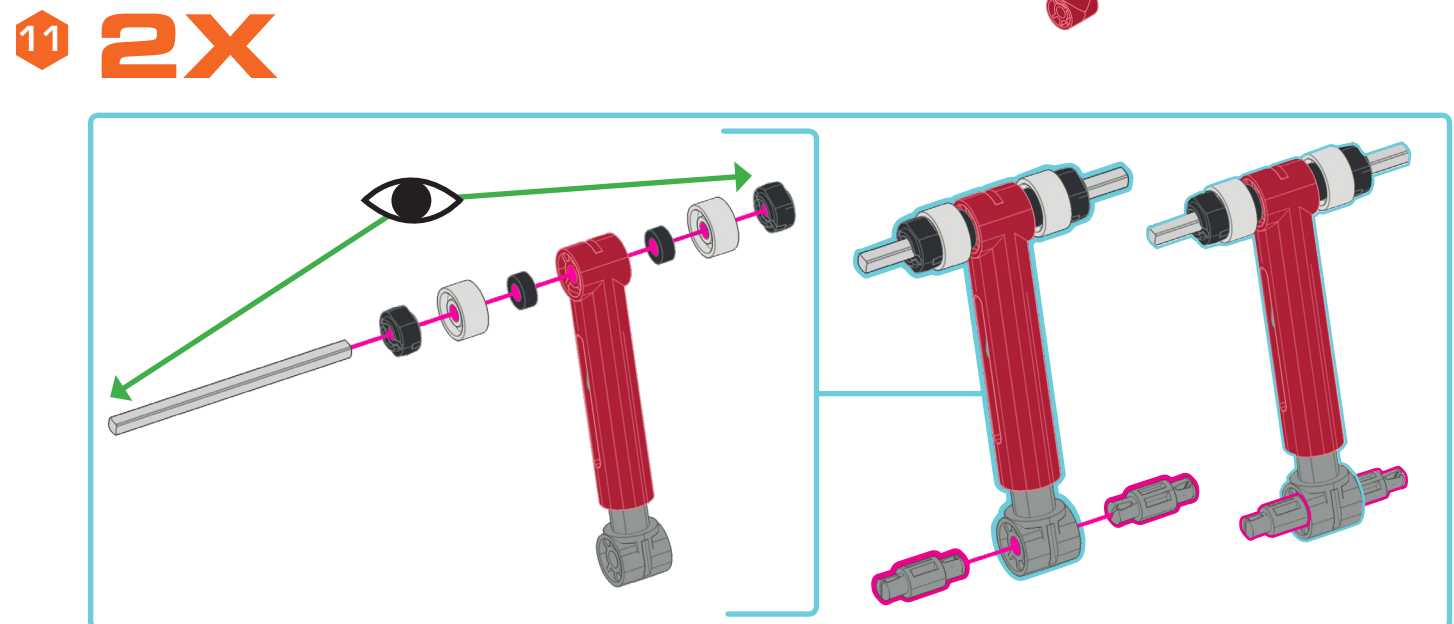
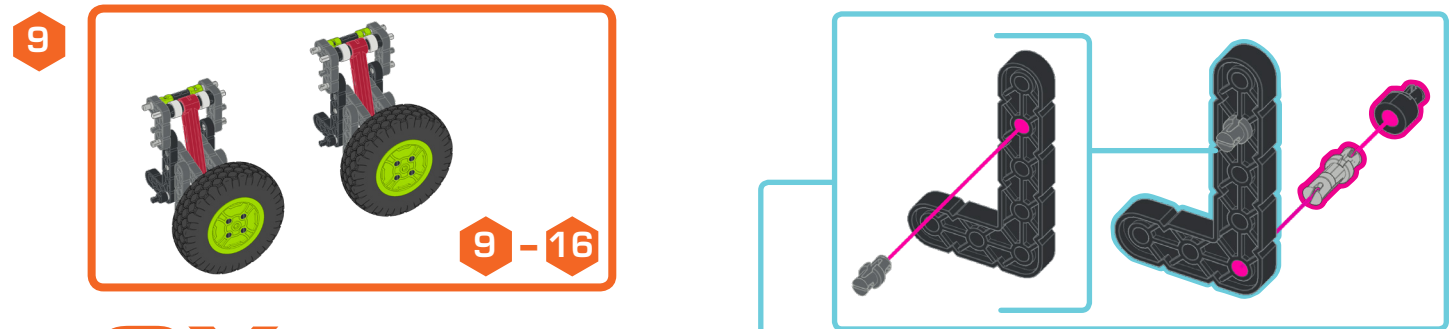
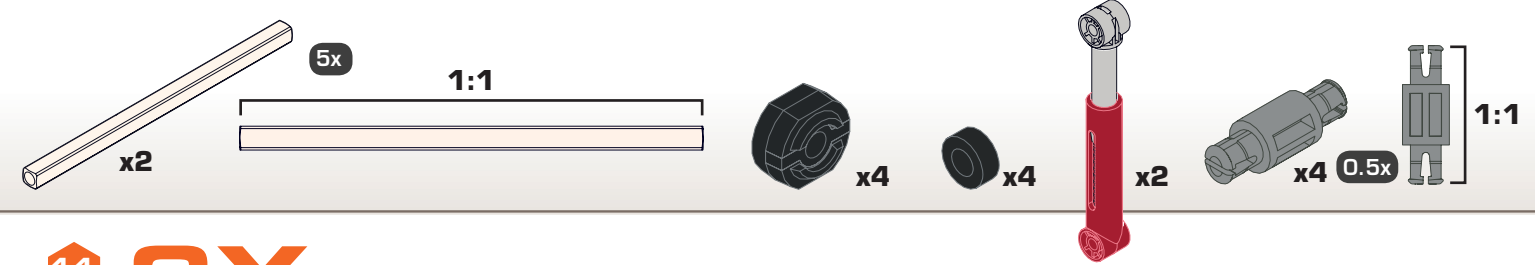
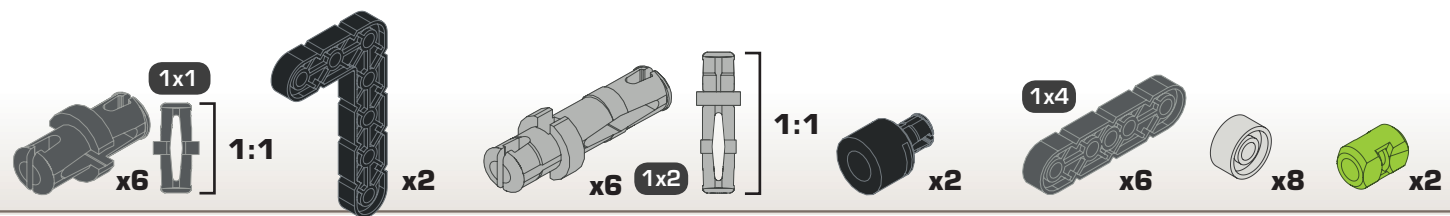

2X

11 2X

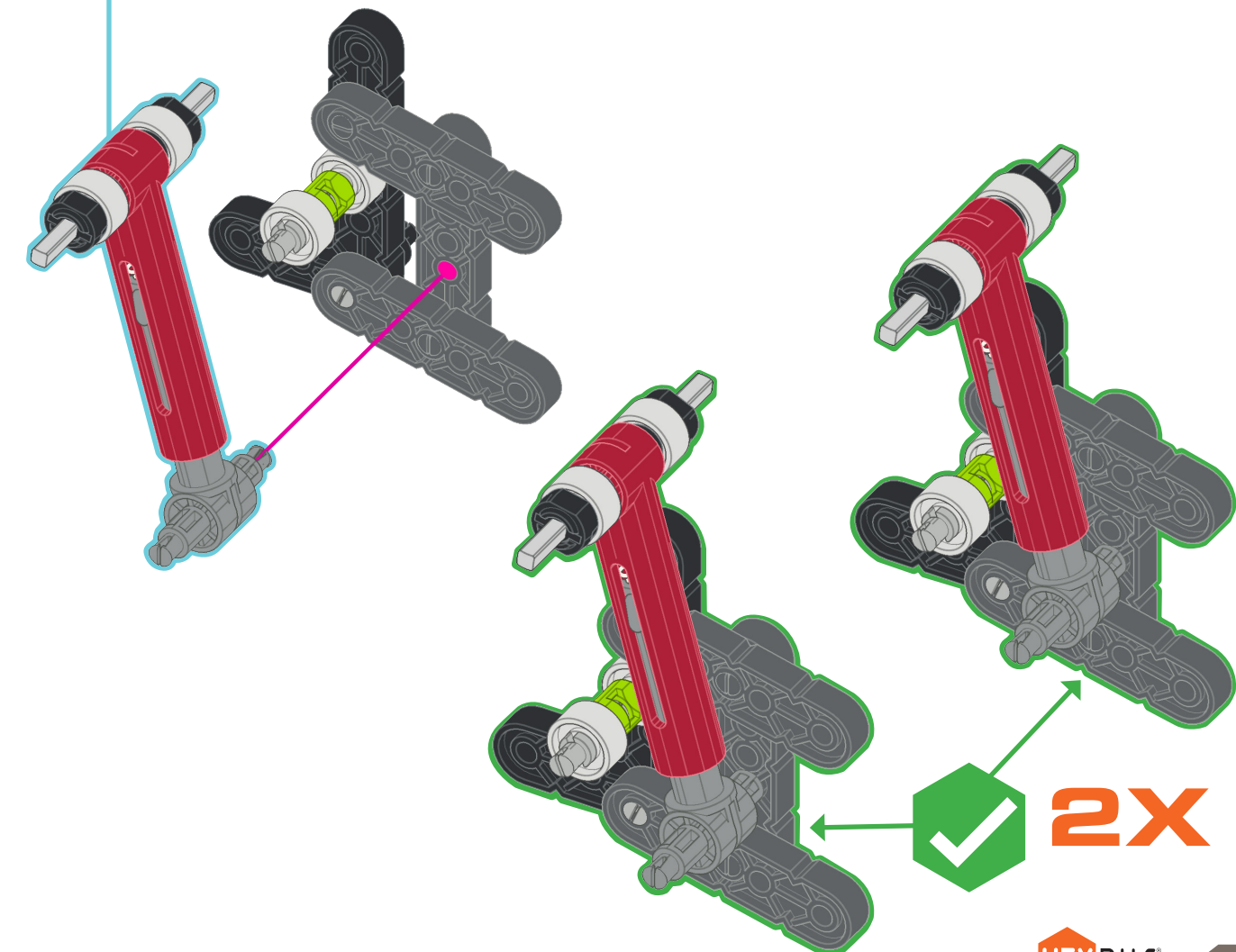
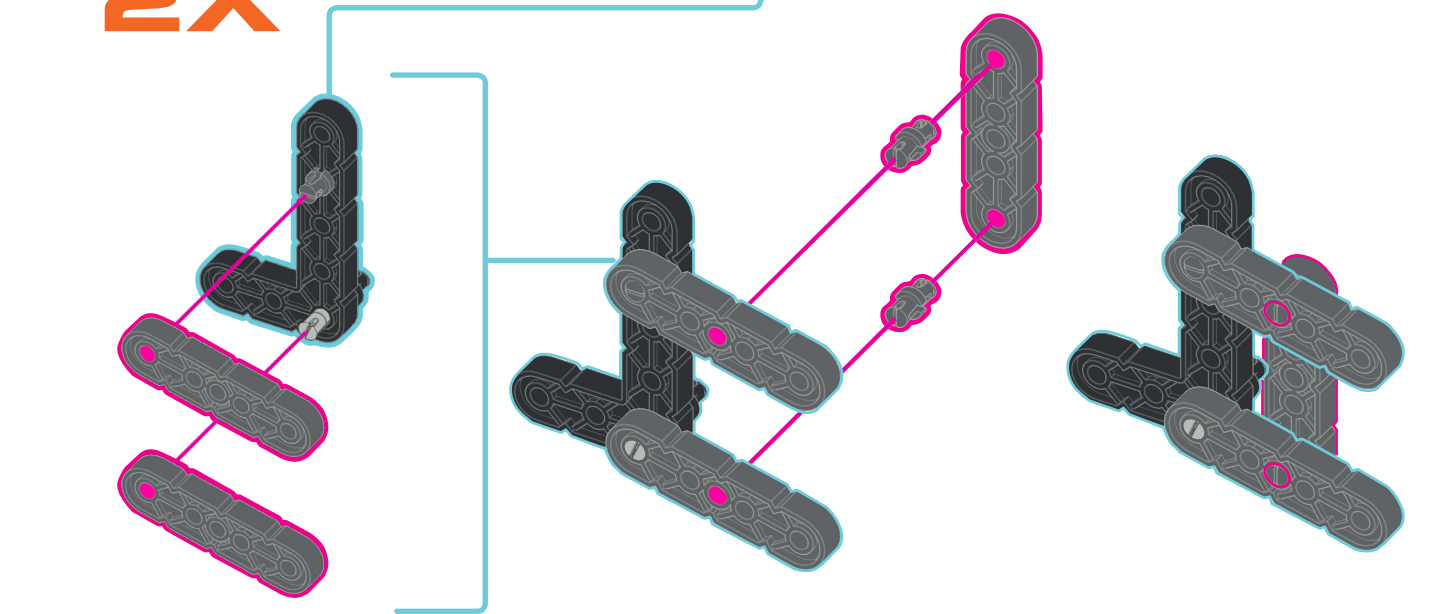

10 2X

2X

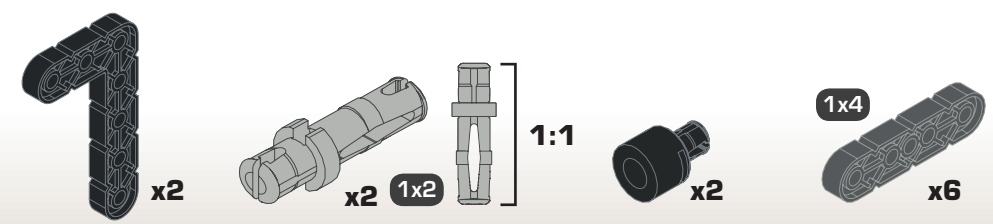
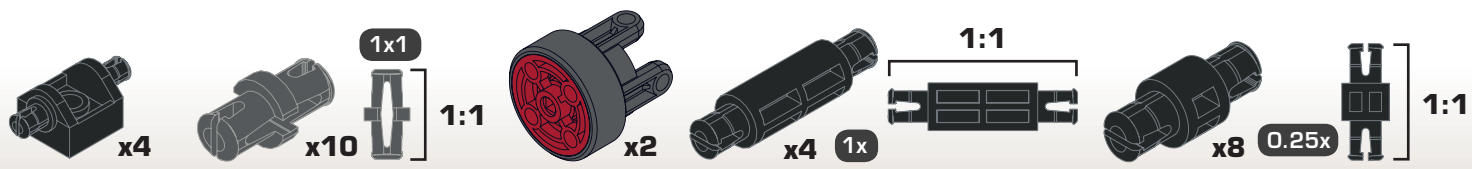

12 **2X**

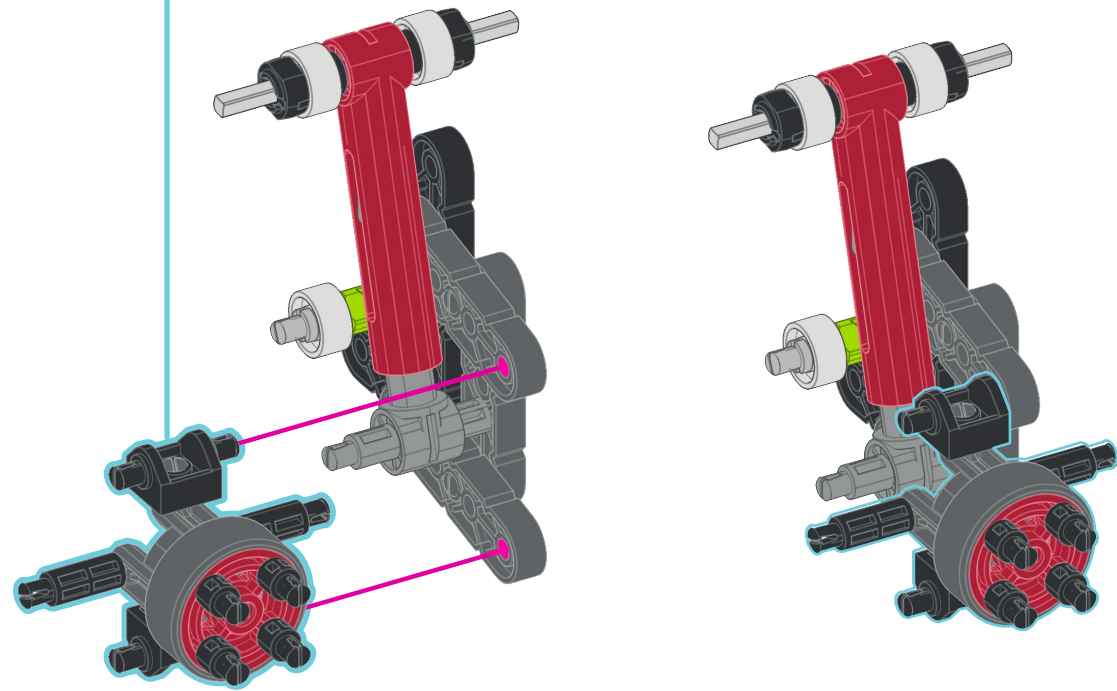
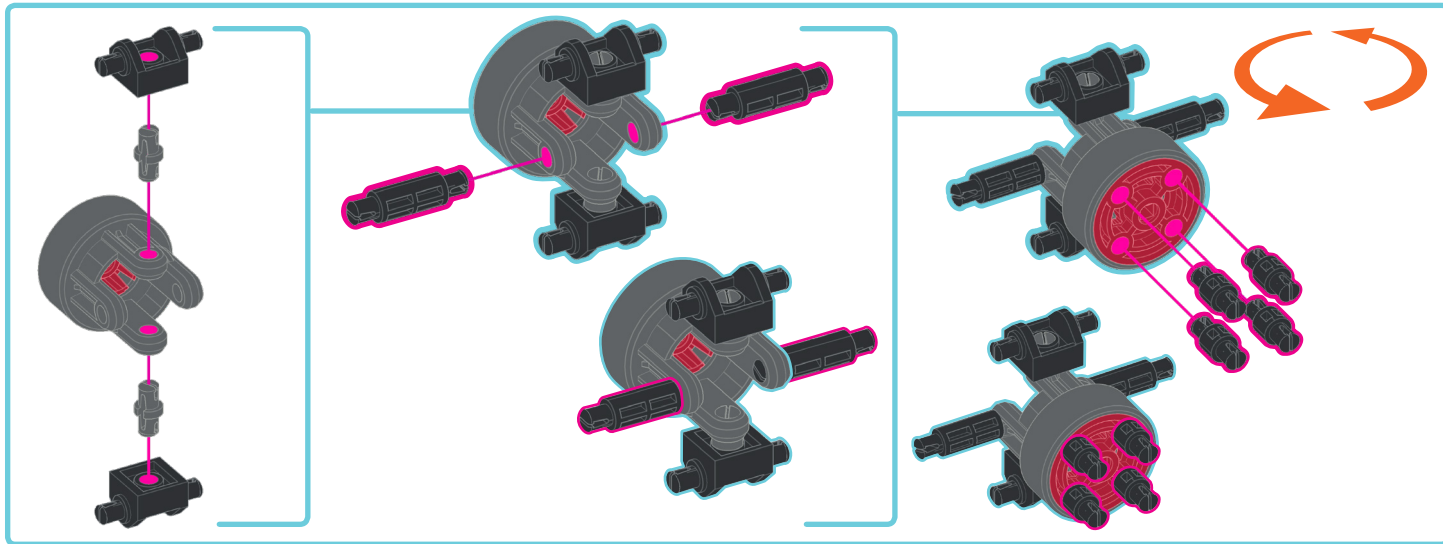

13 **2X**

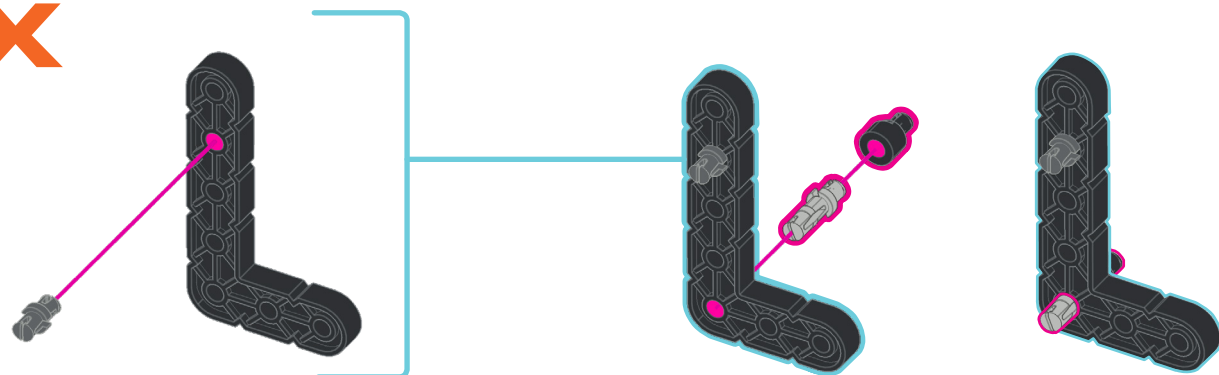

14 **2X**

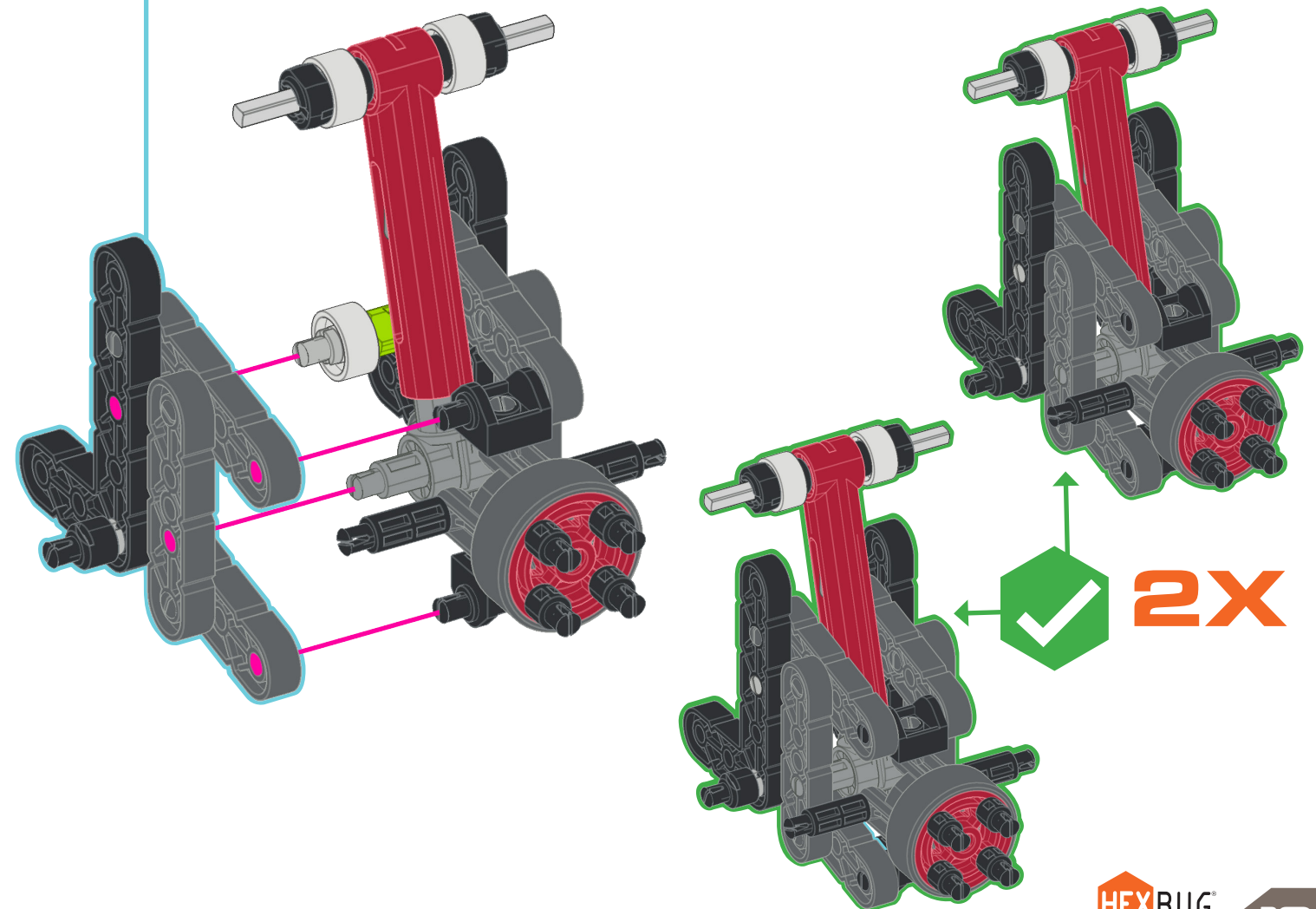
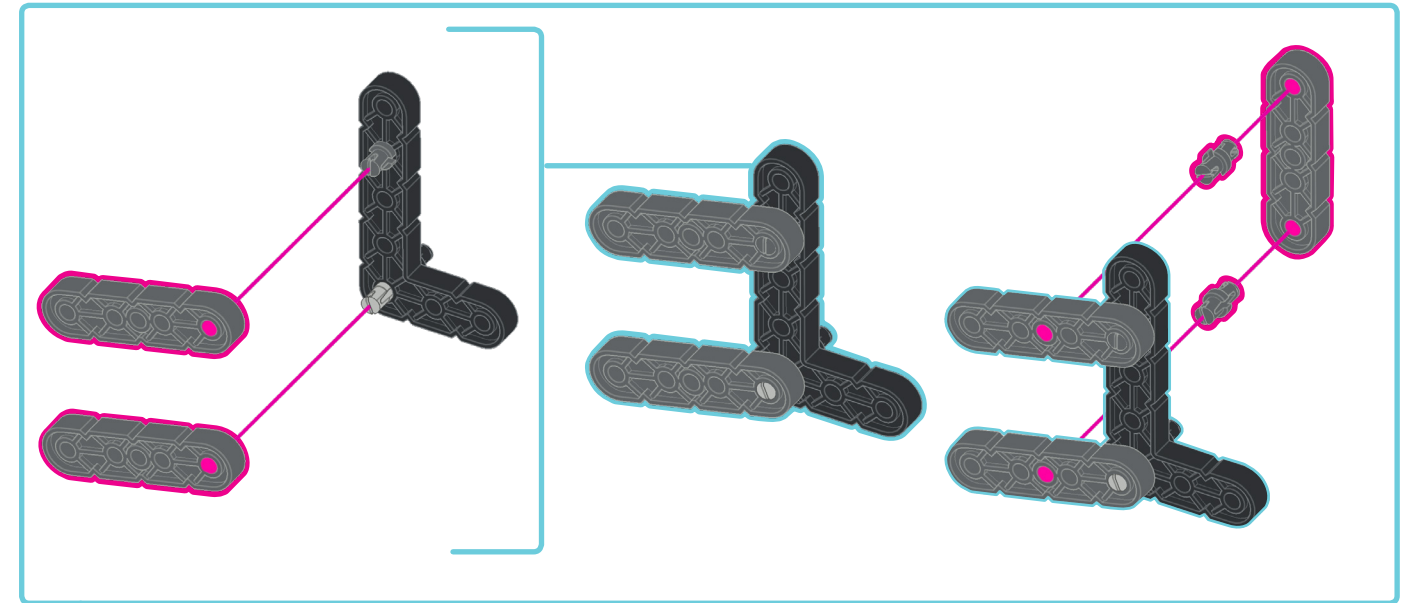

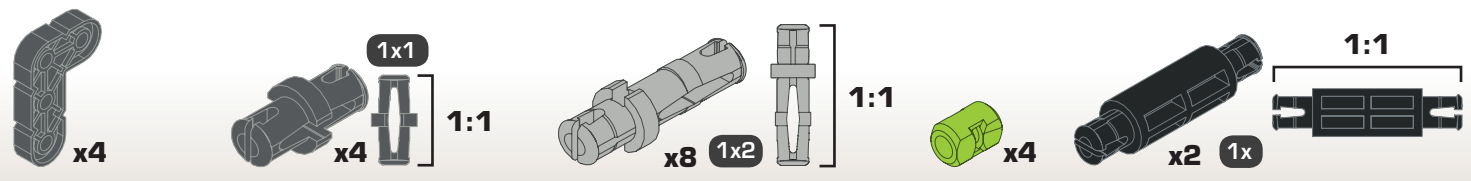

15 2X

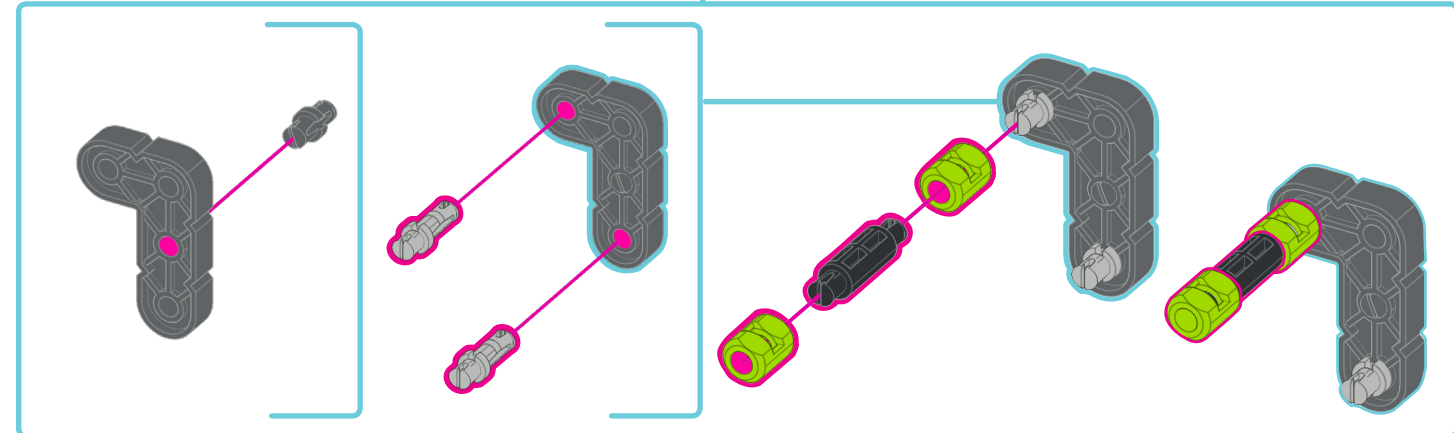
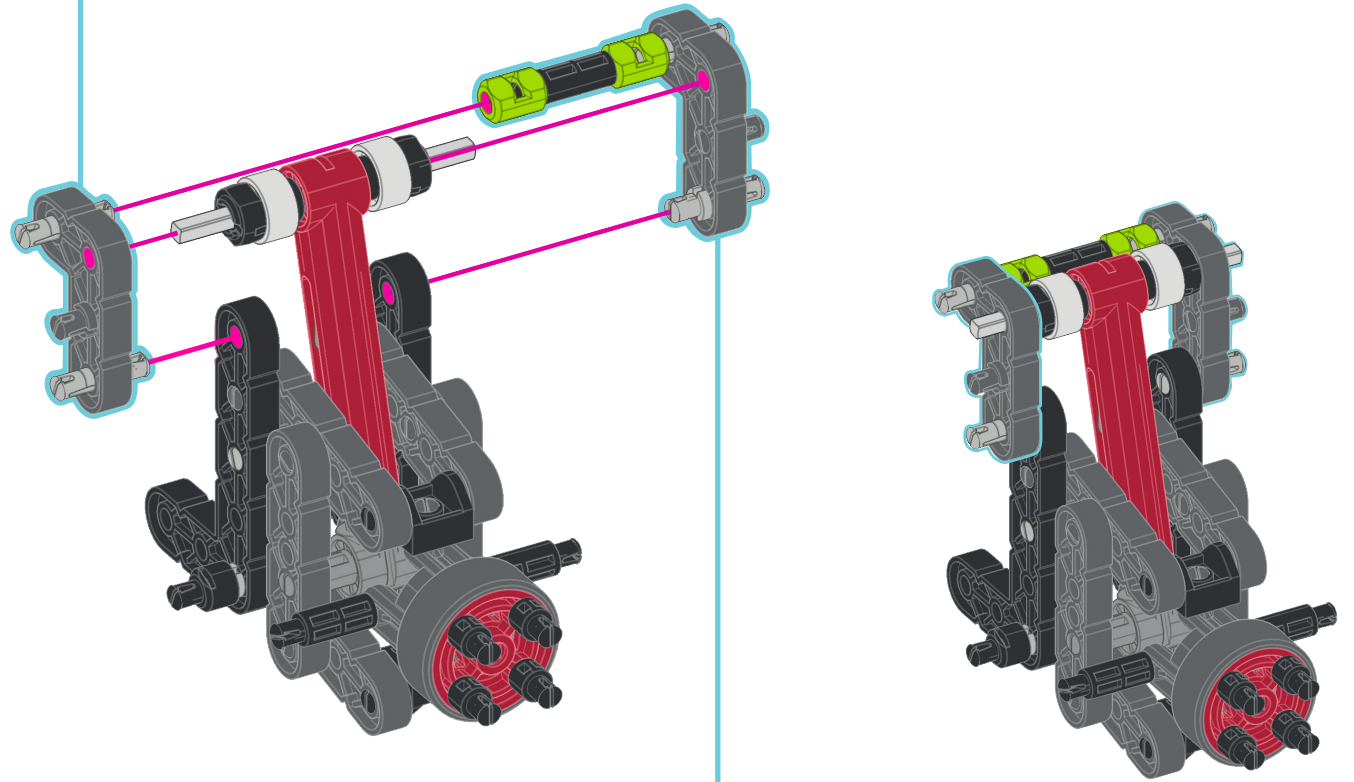
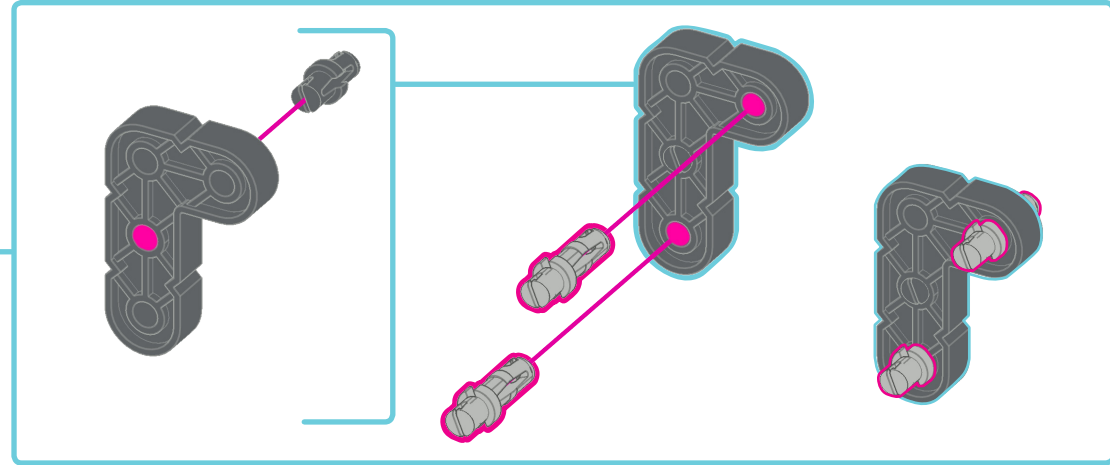

16 2X

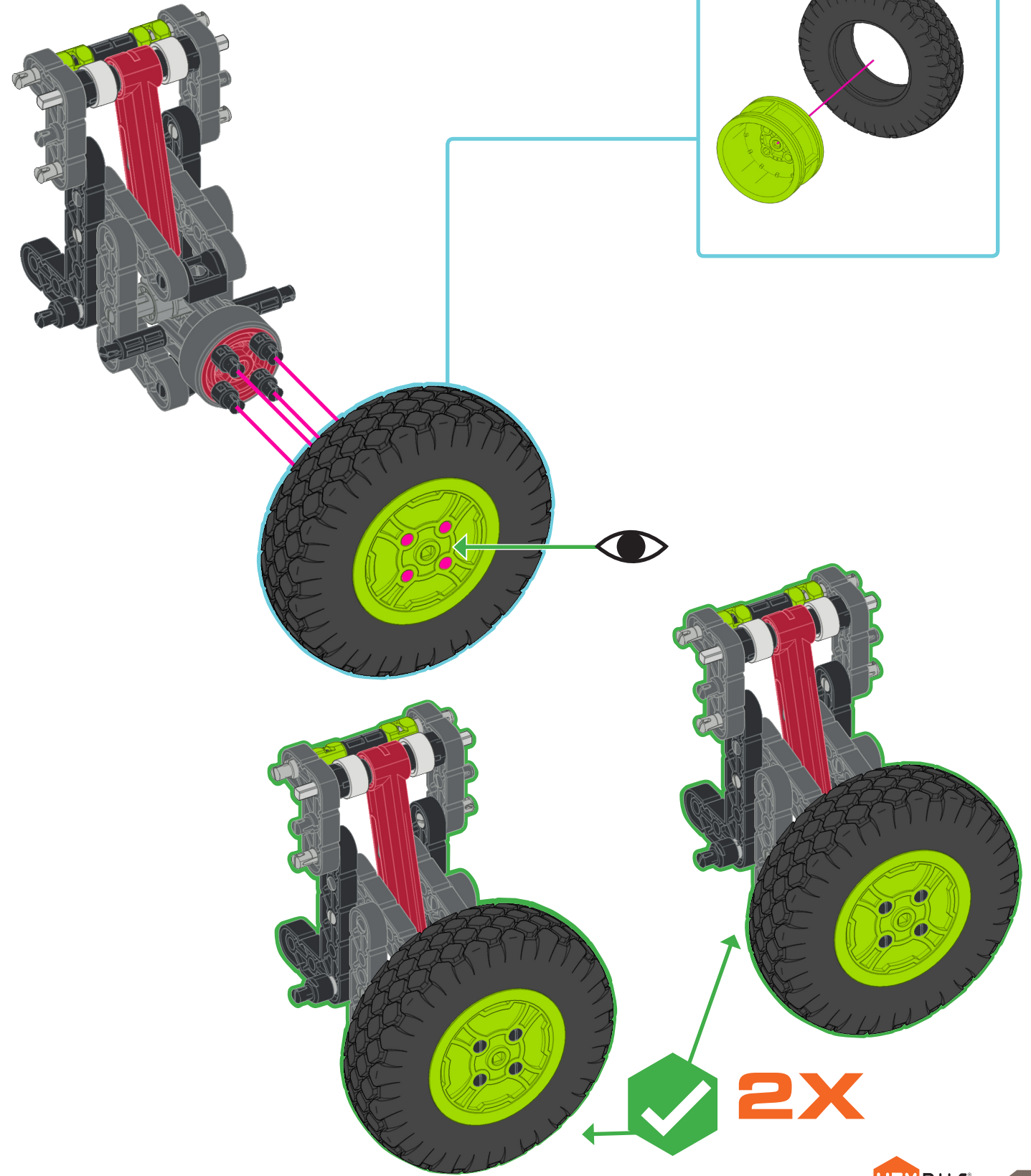
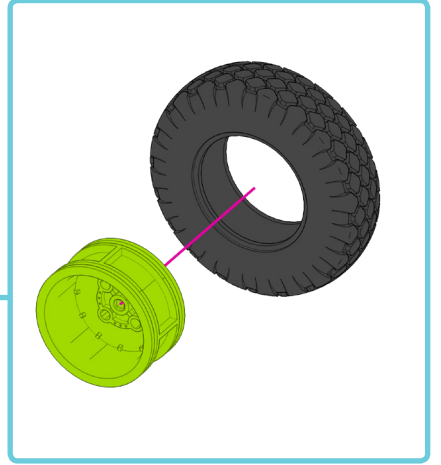

✓ 2X

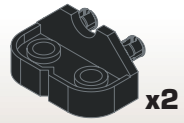
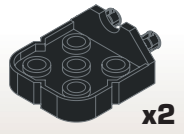

17

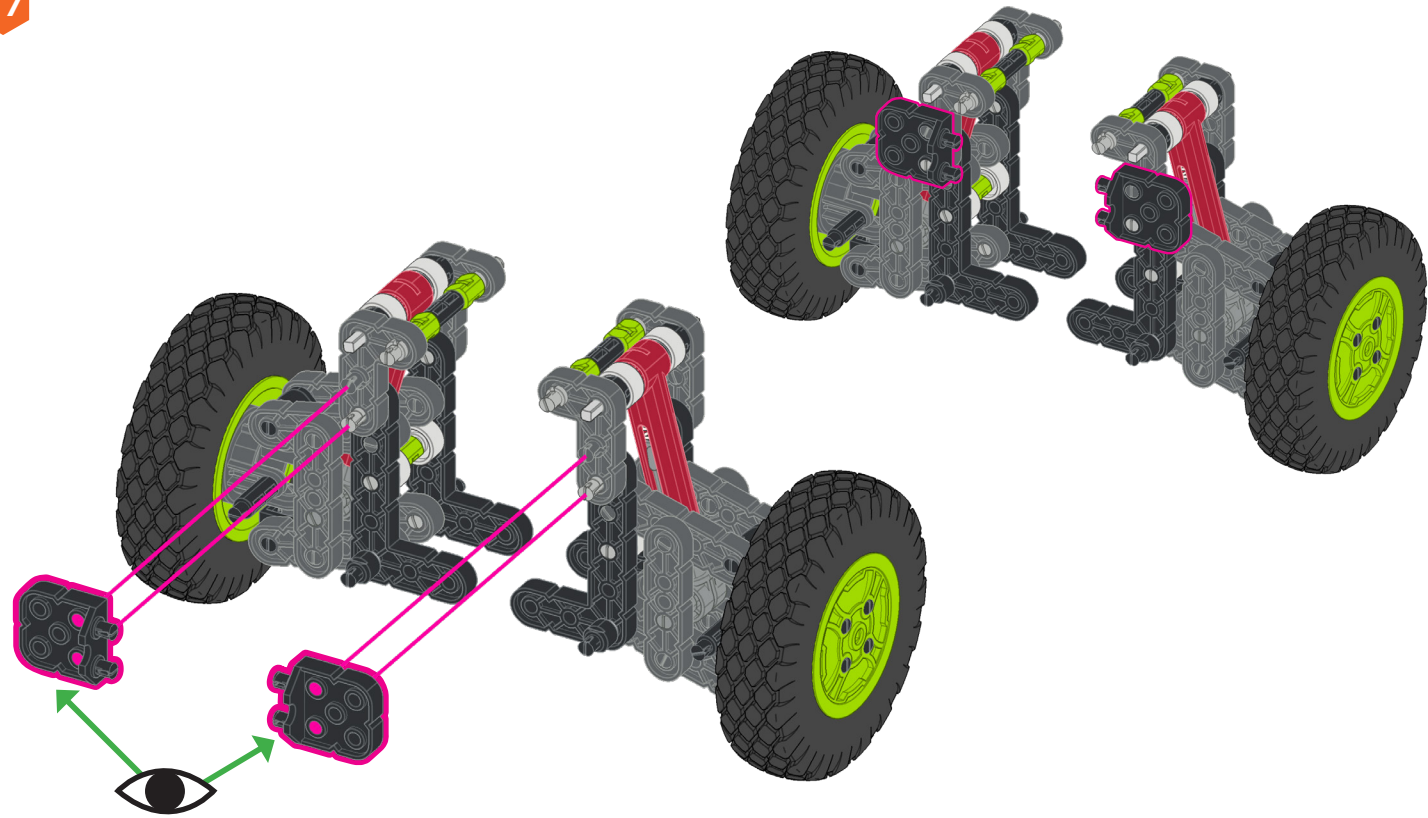

18

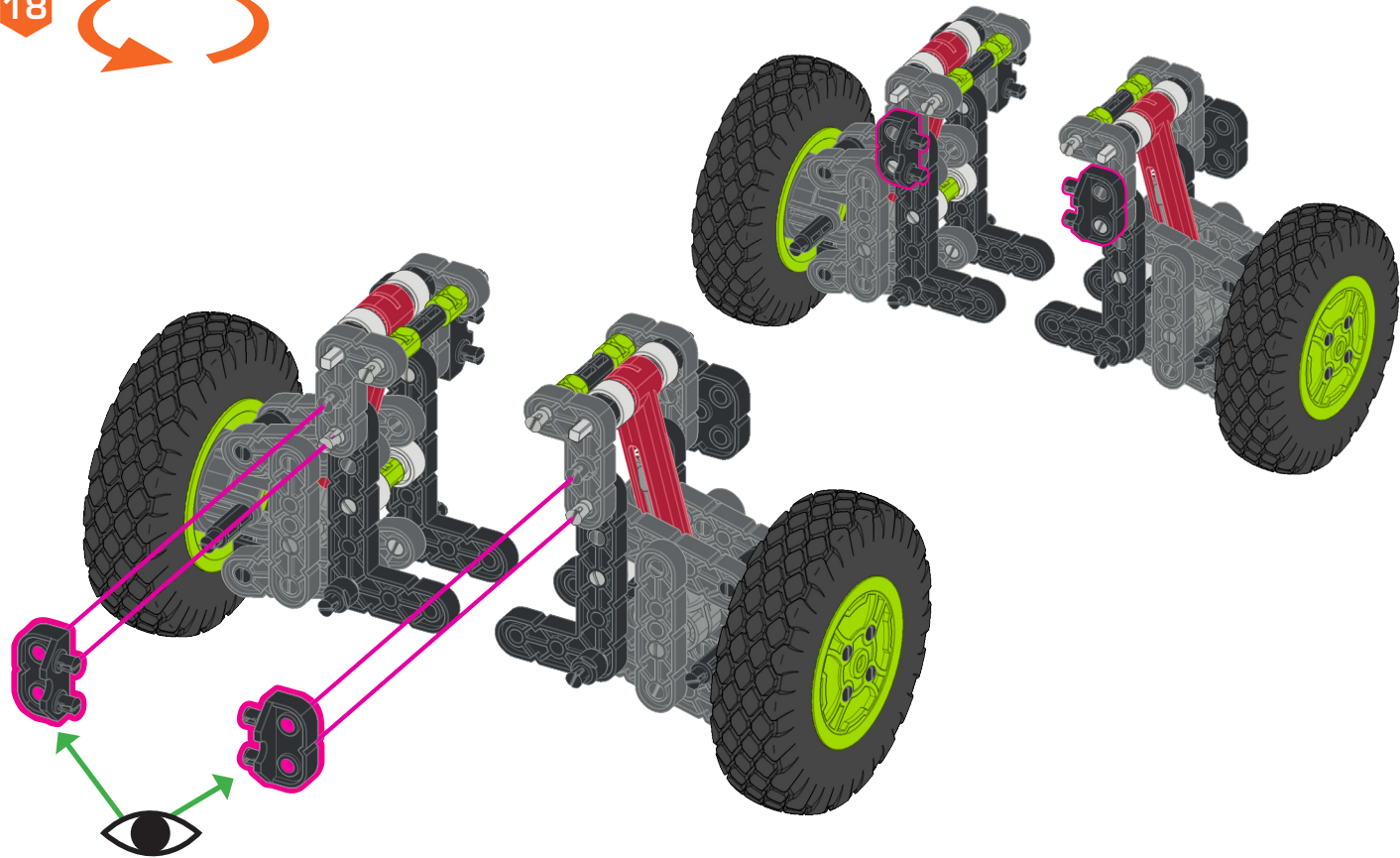

19

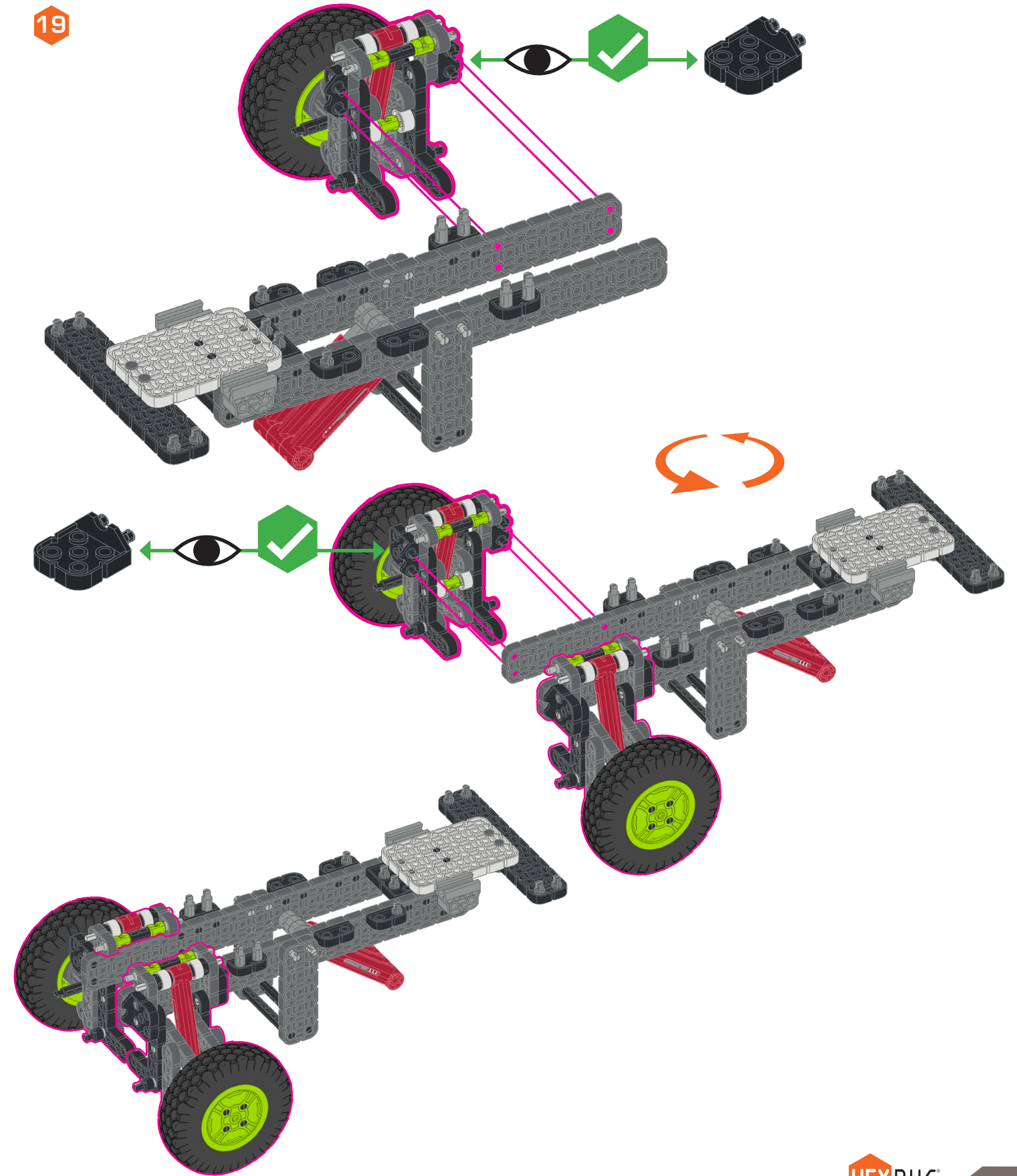

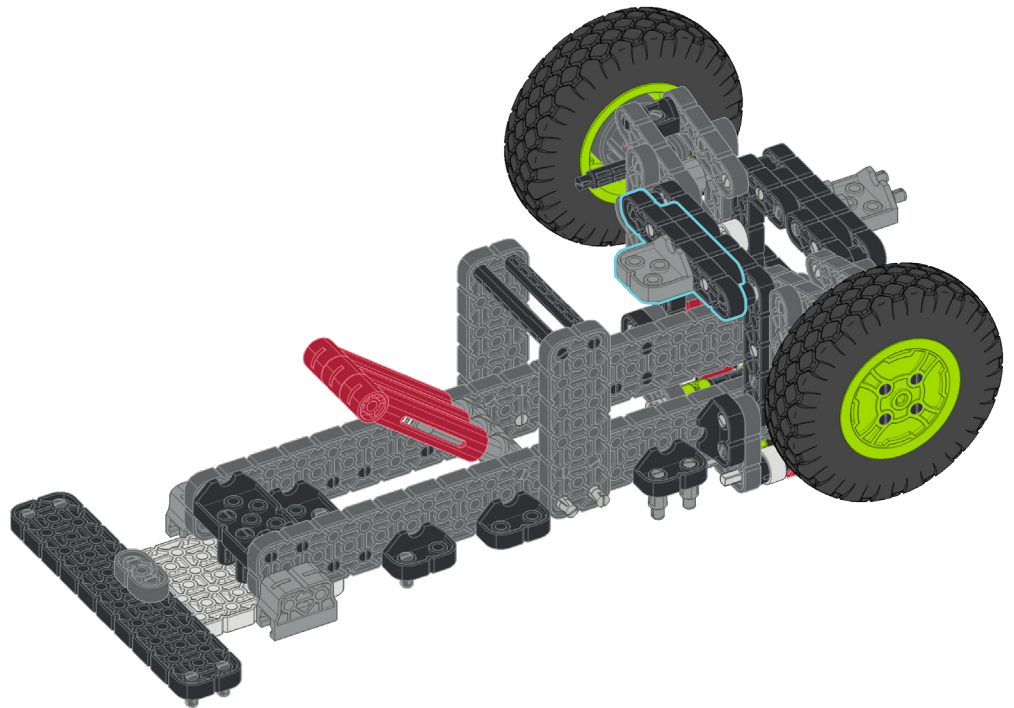
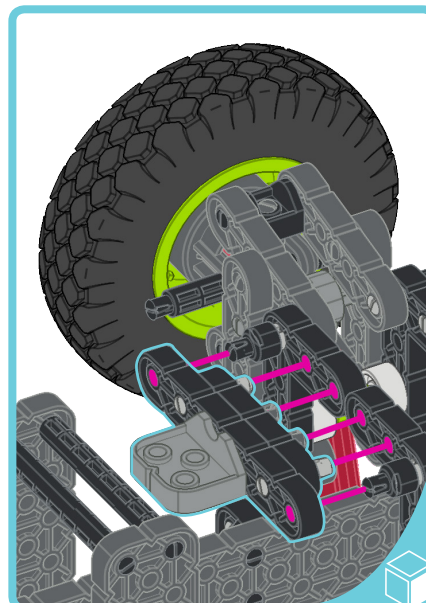
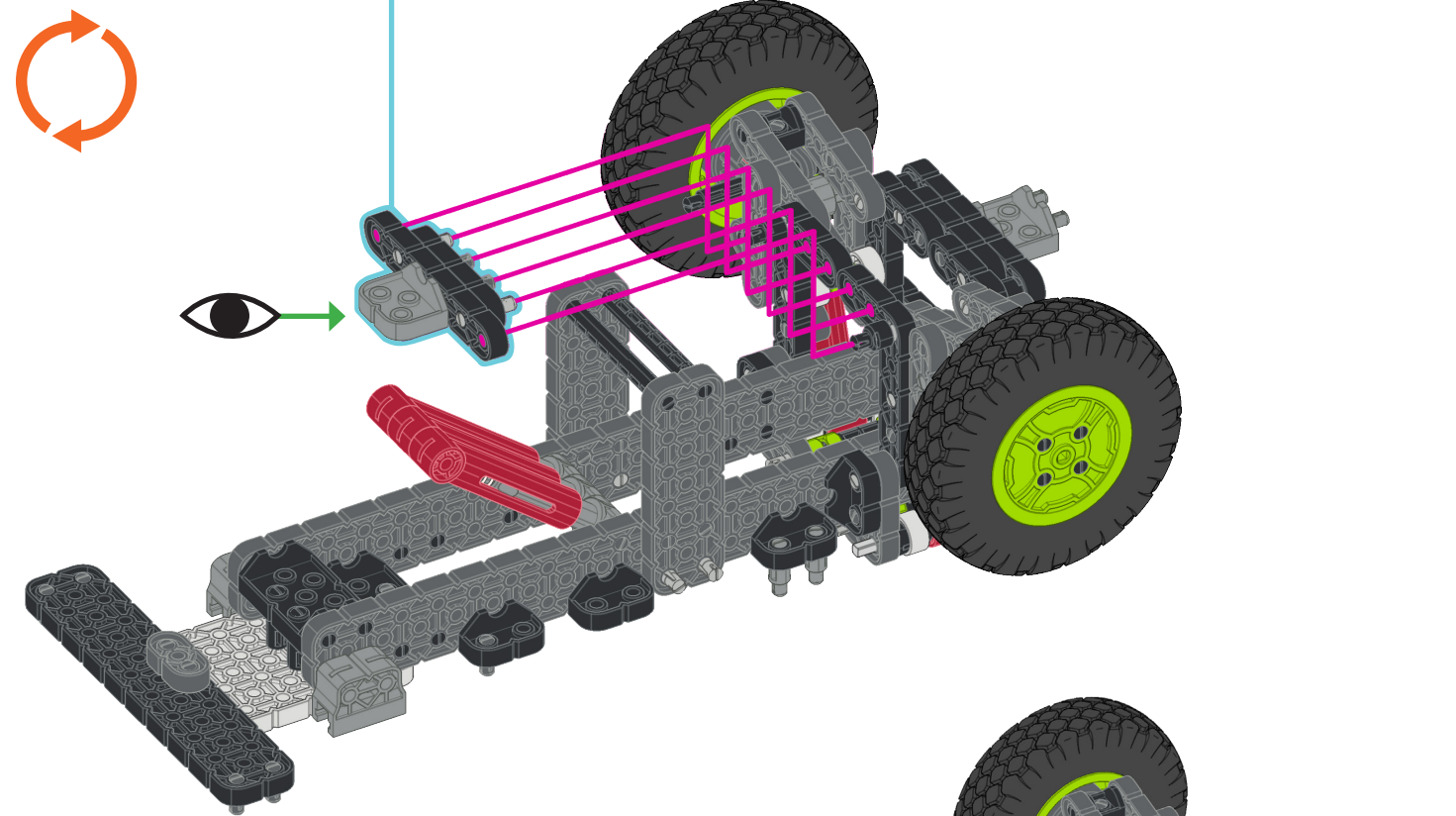
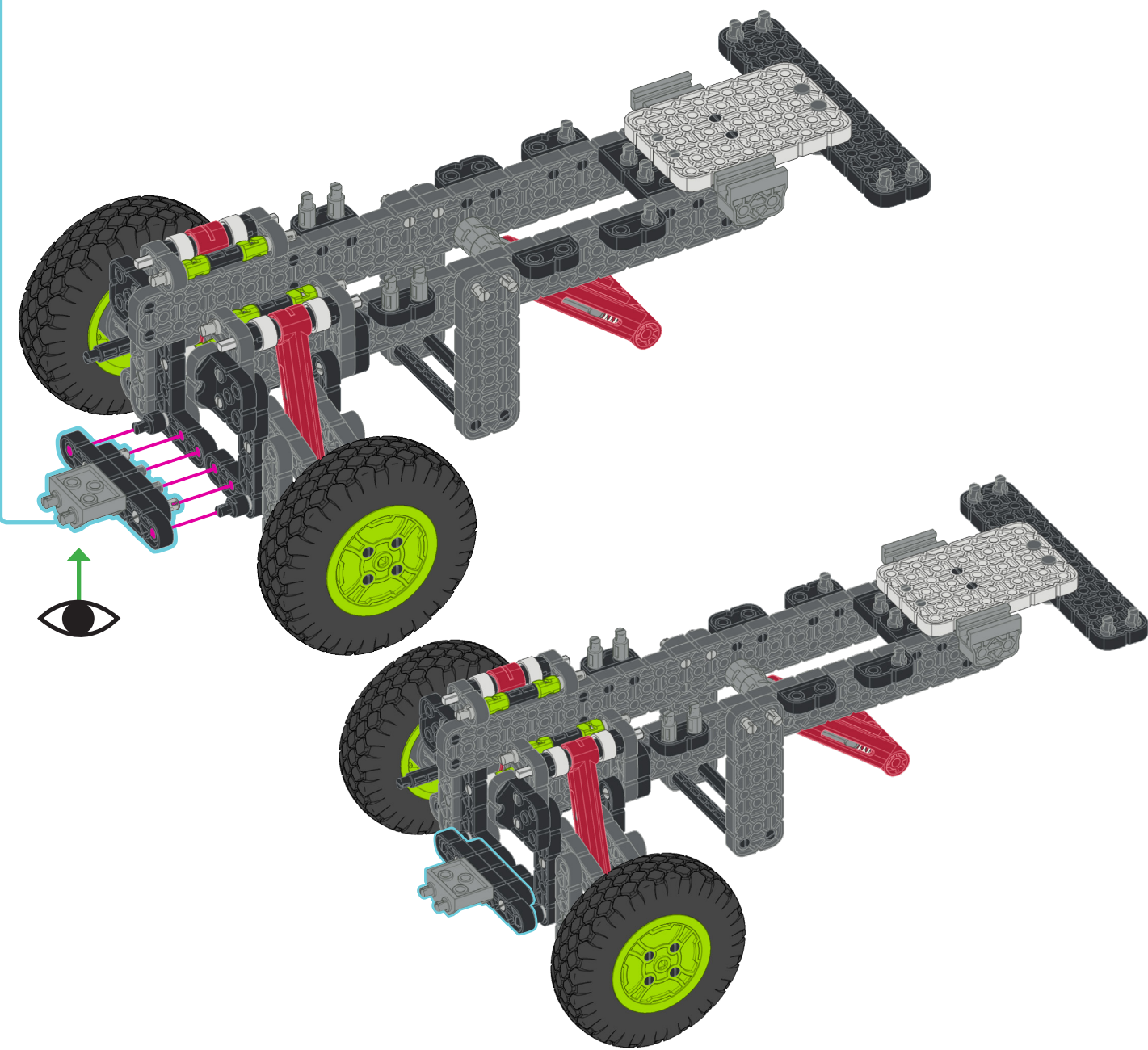
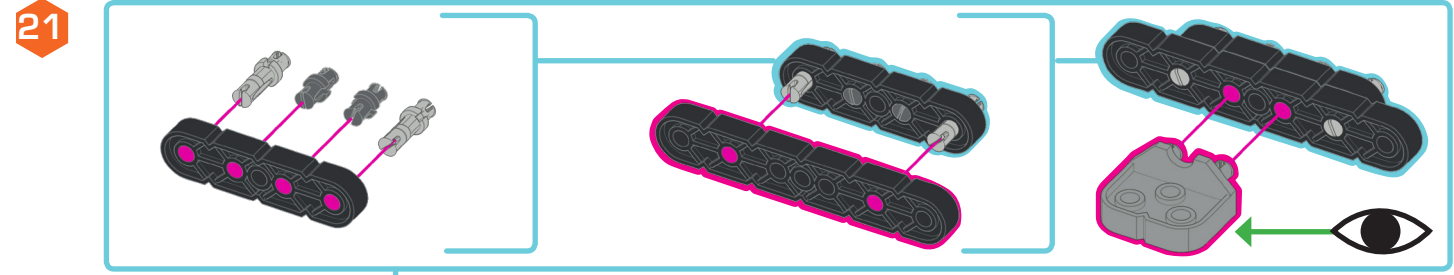
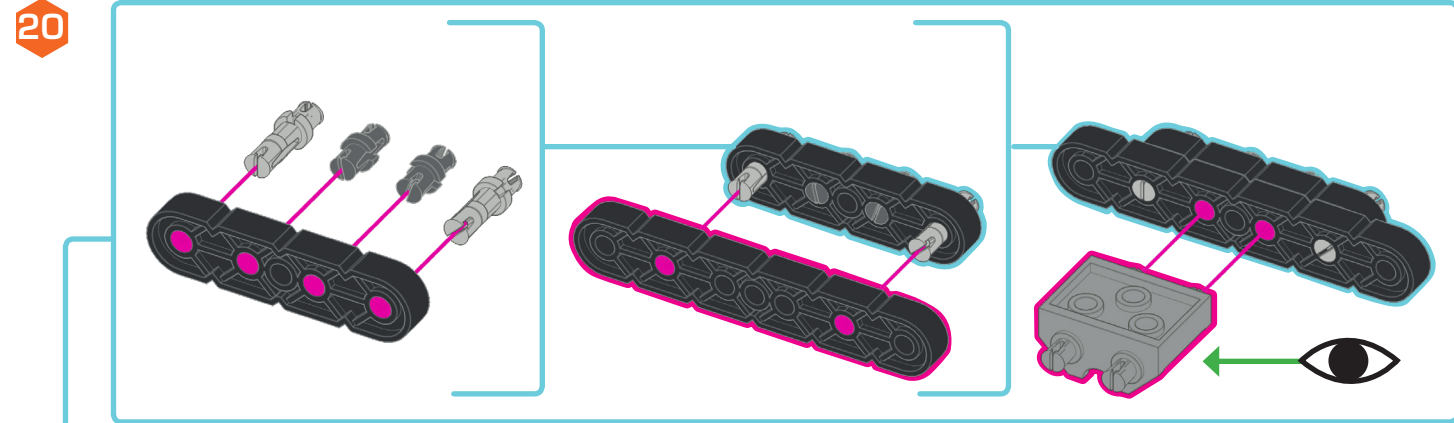
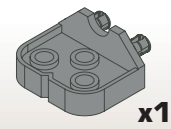
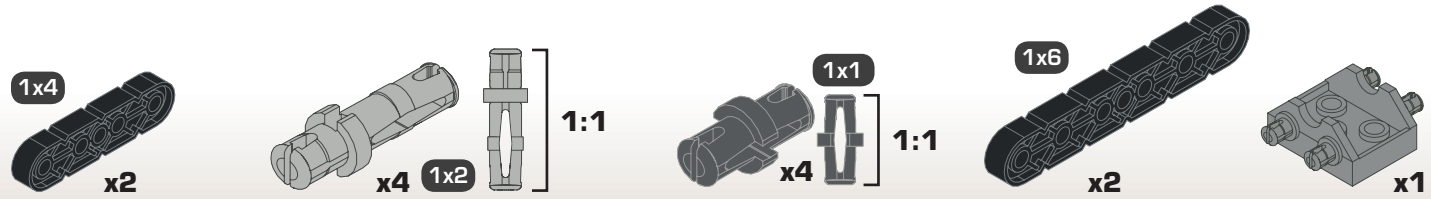

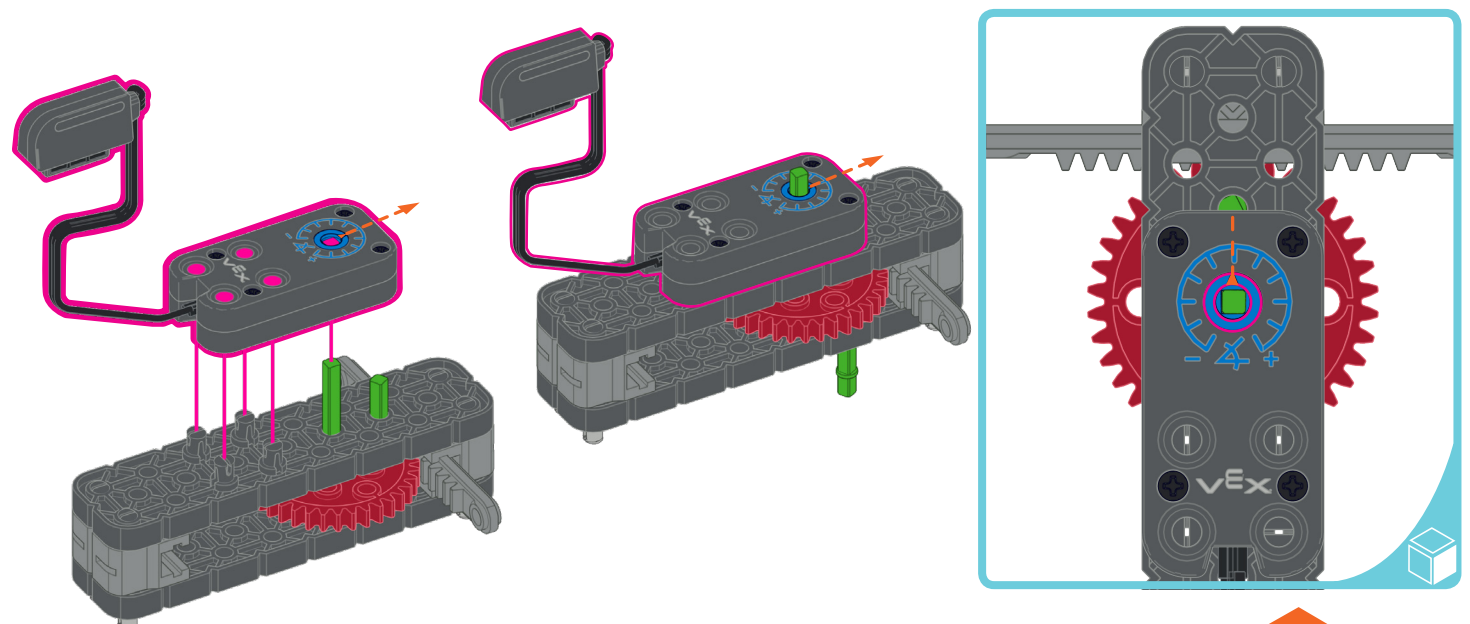
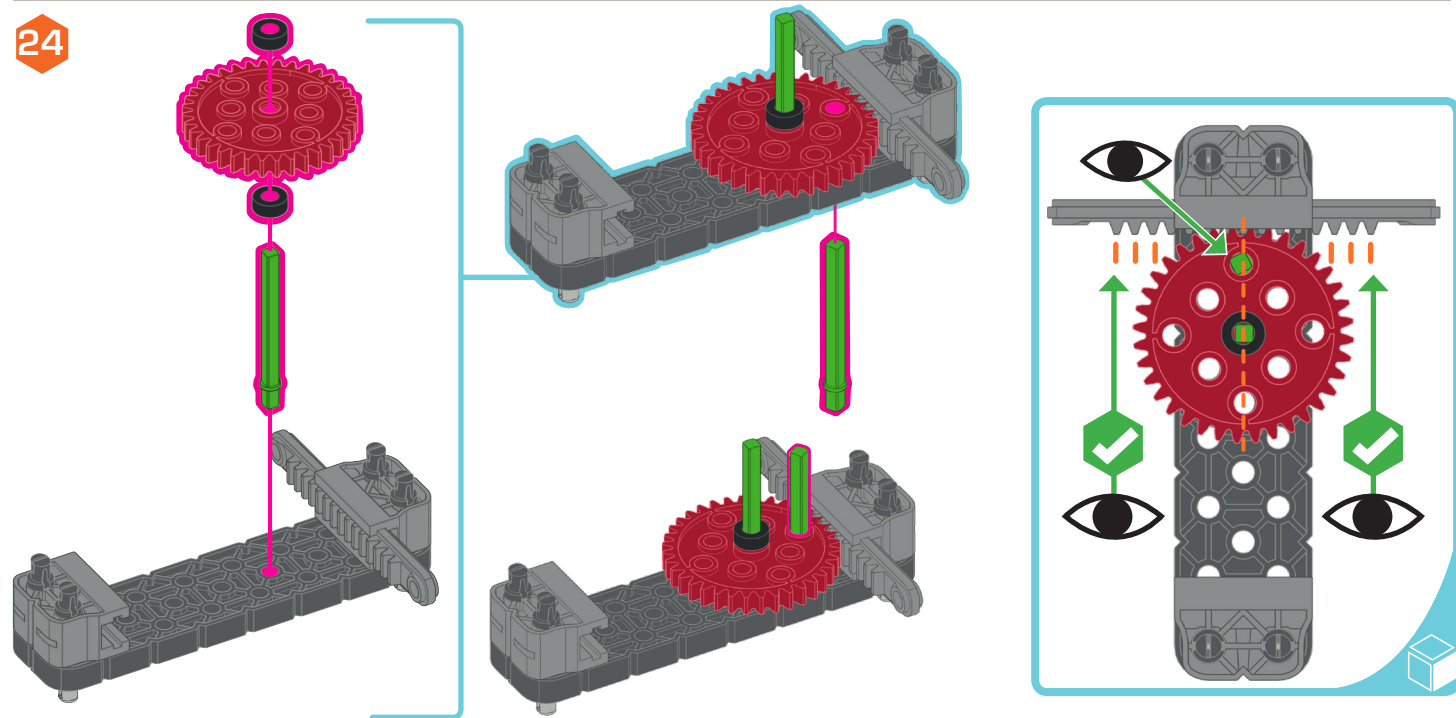
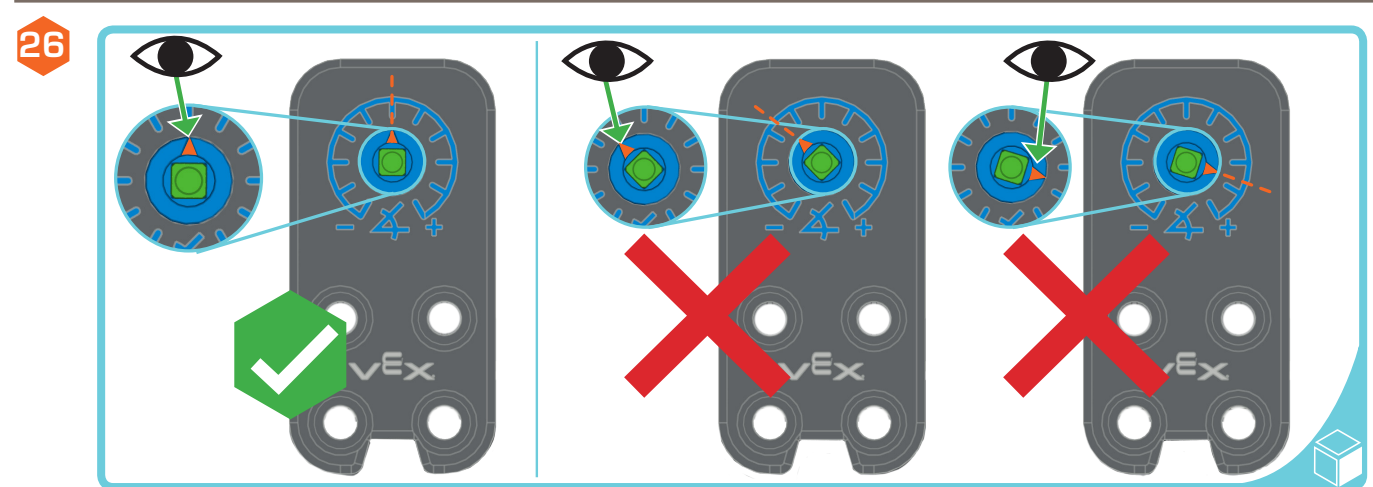
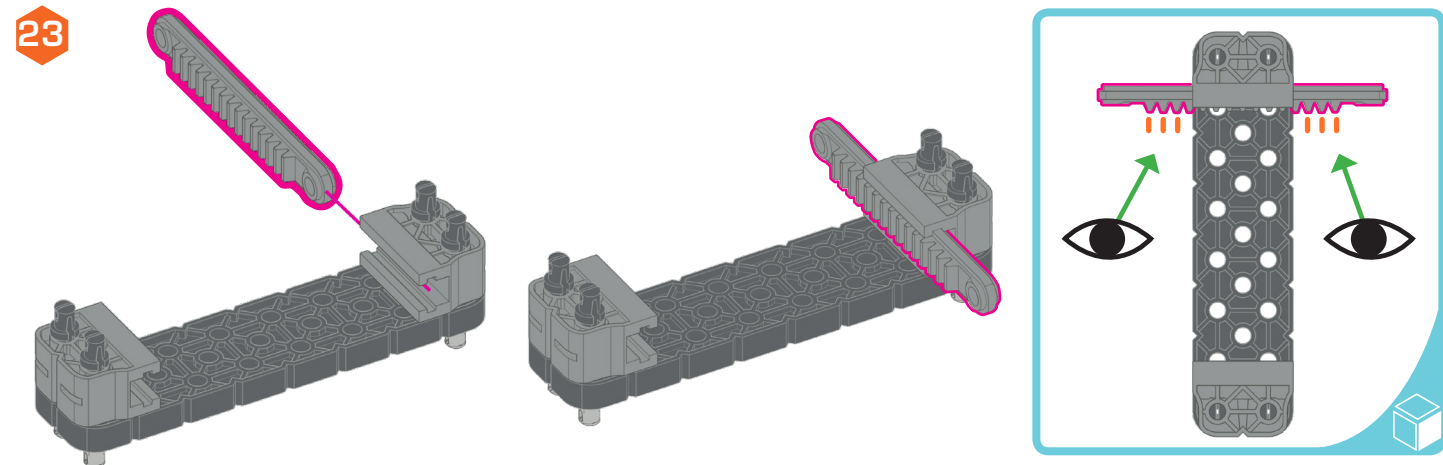
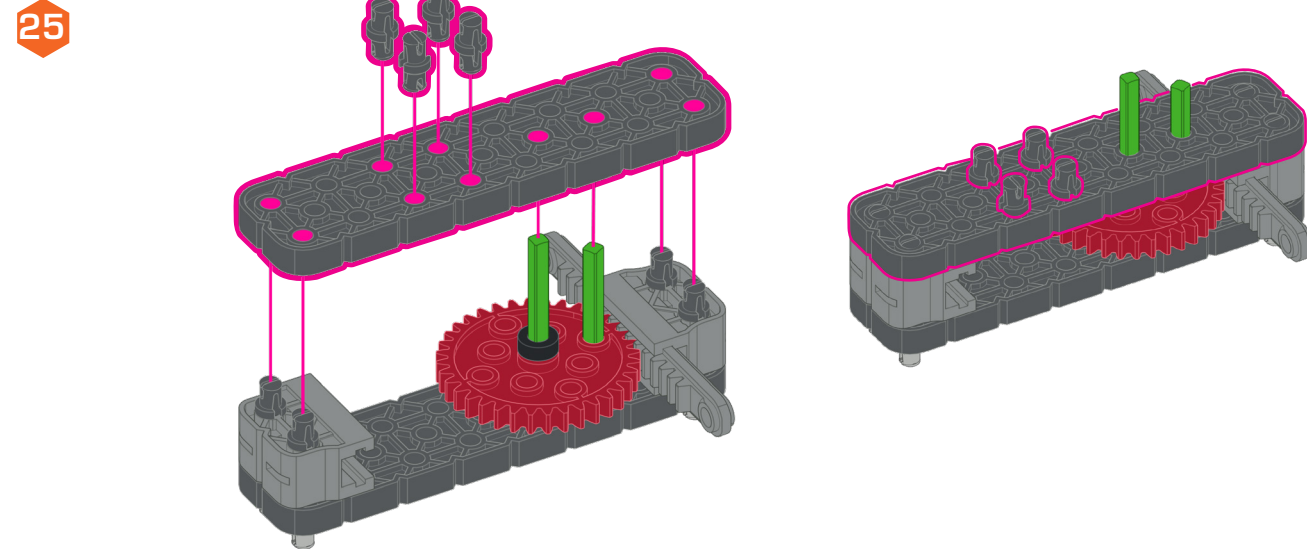
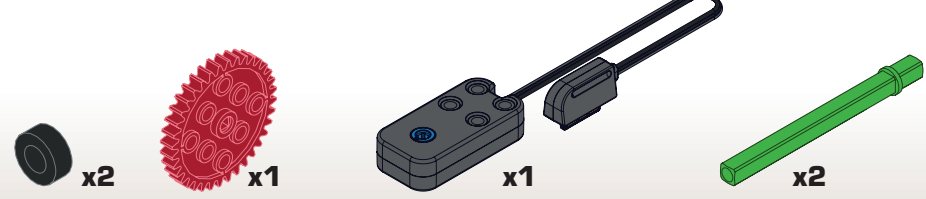
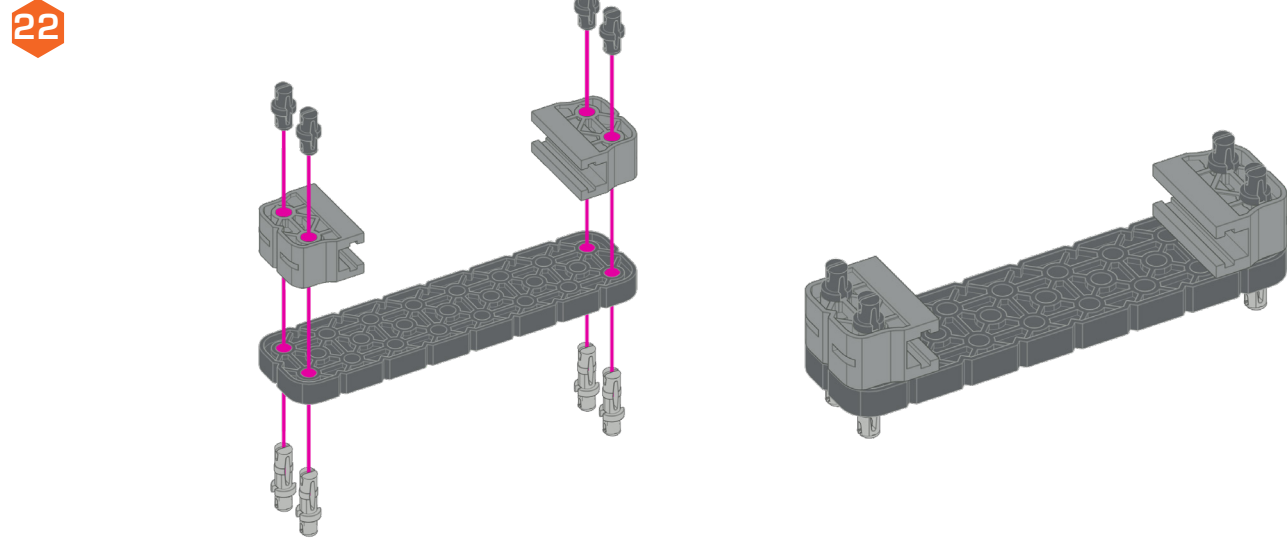
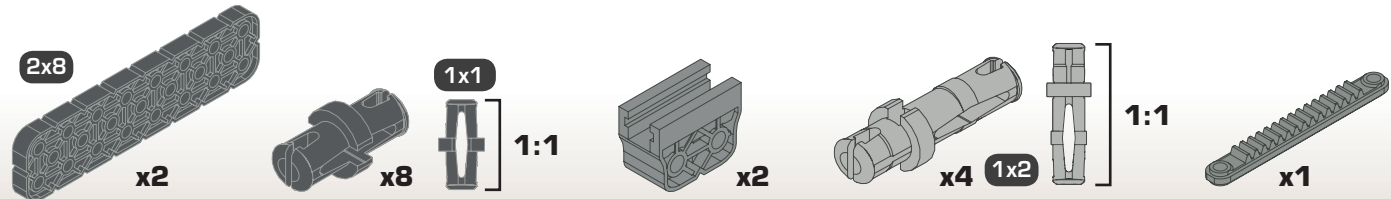

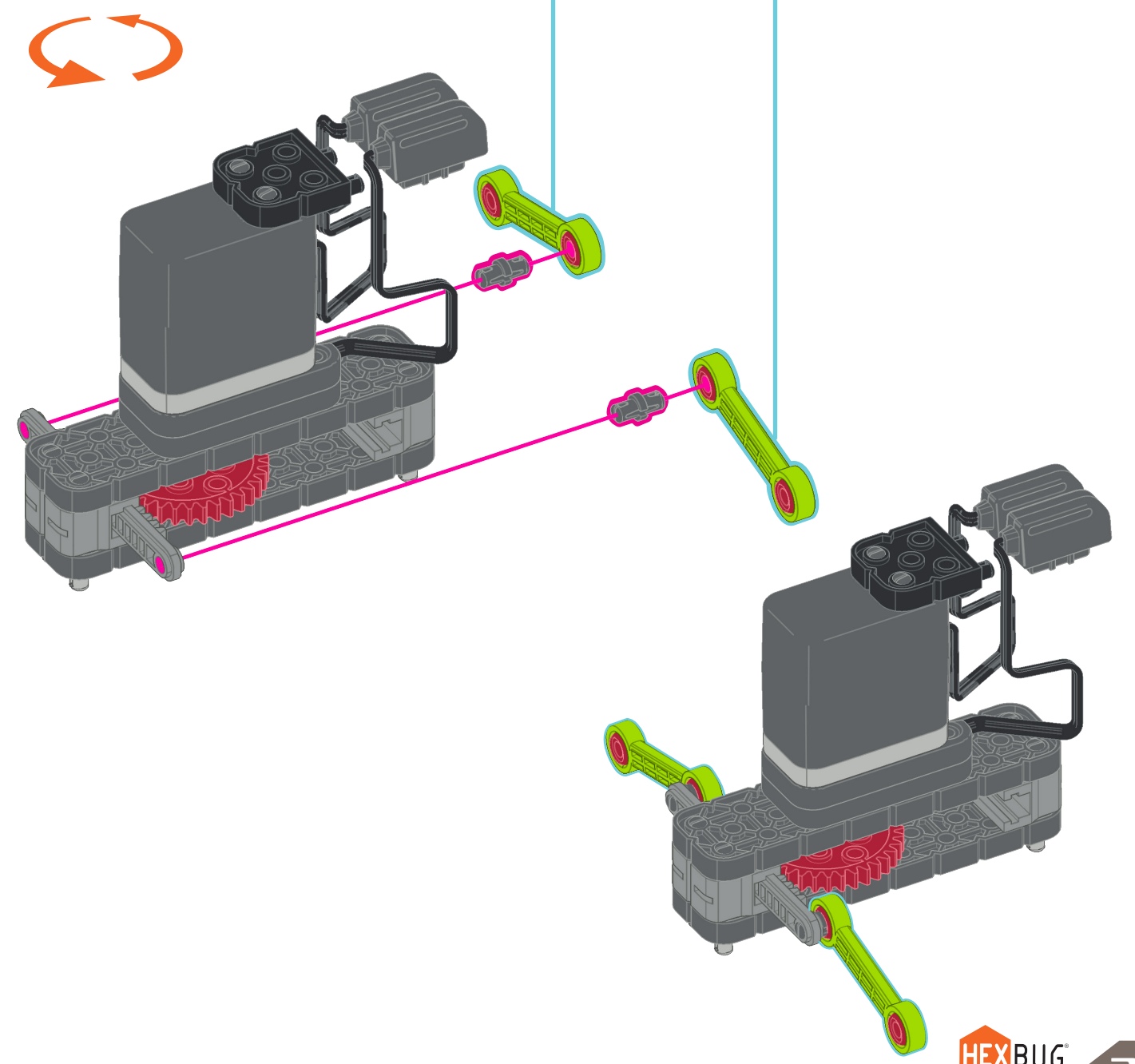
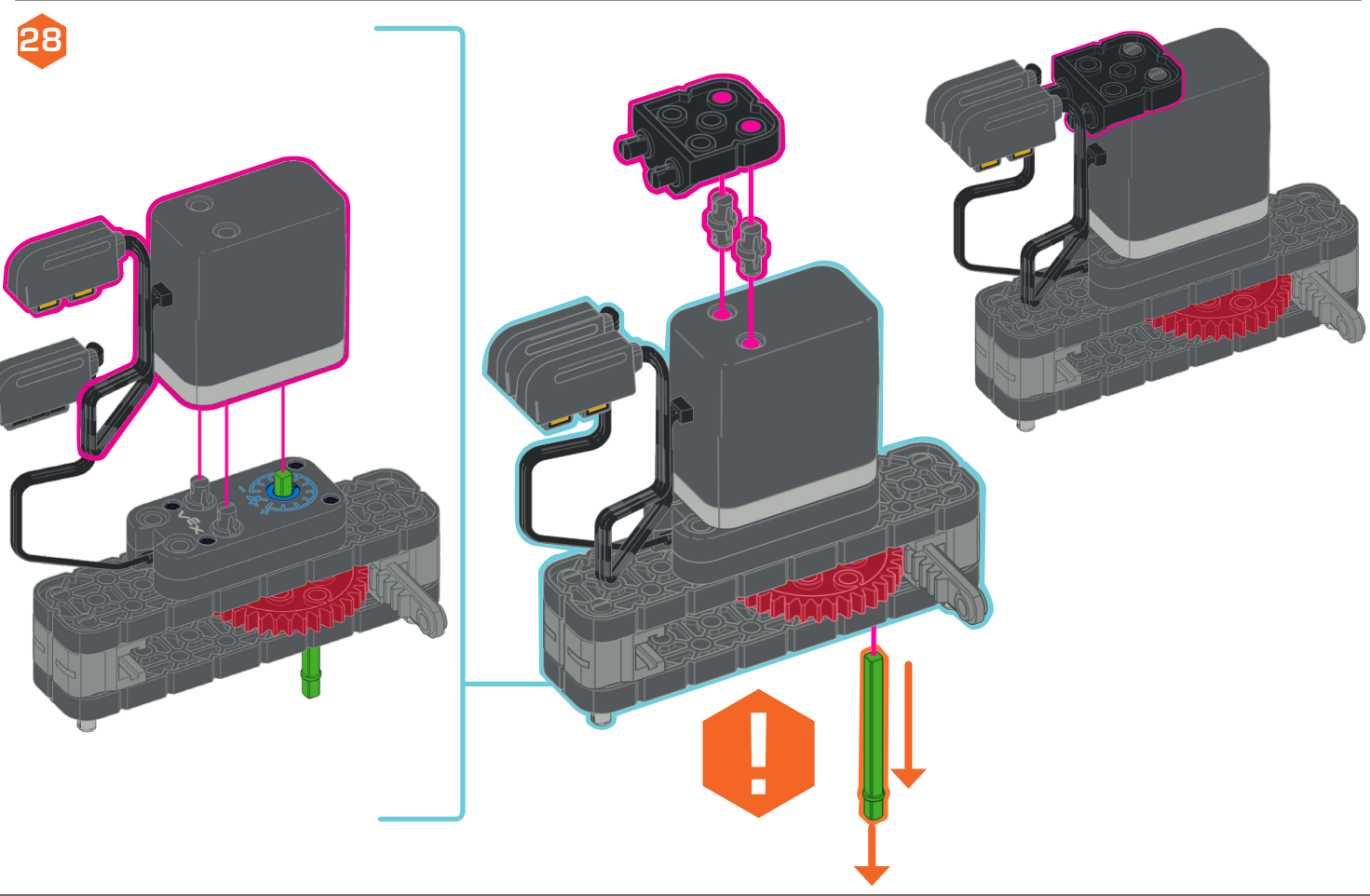
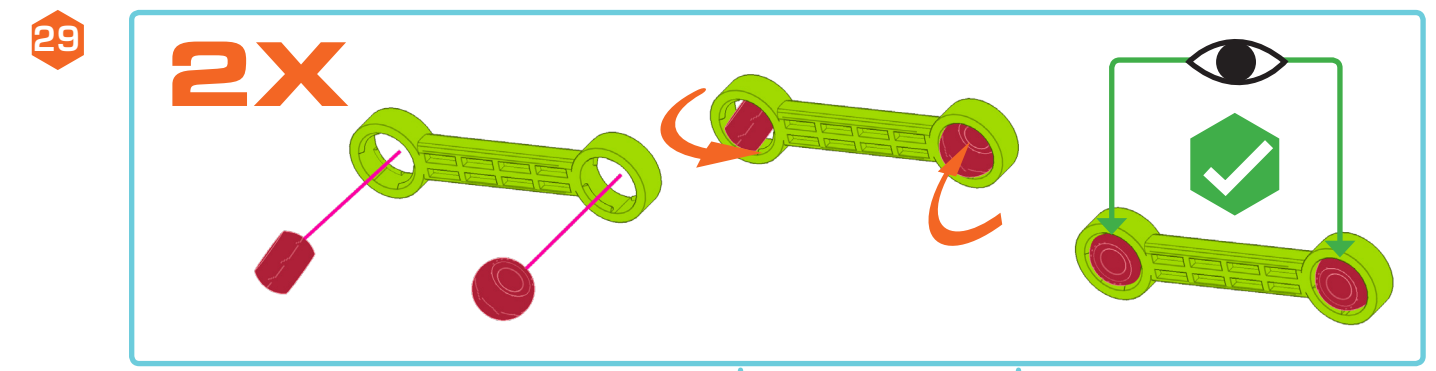
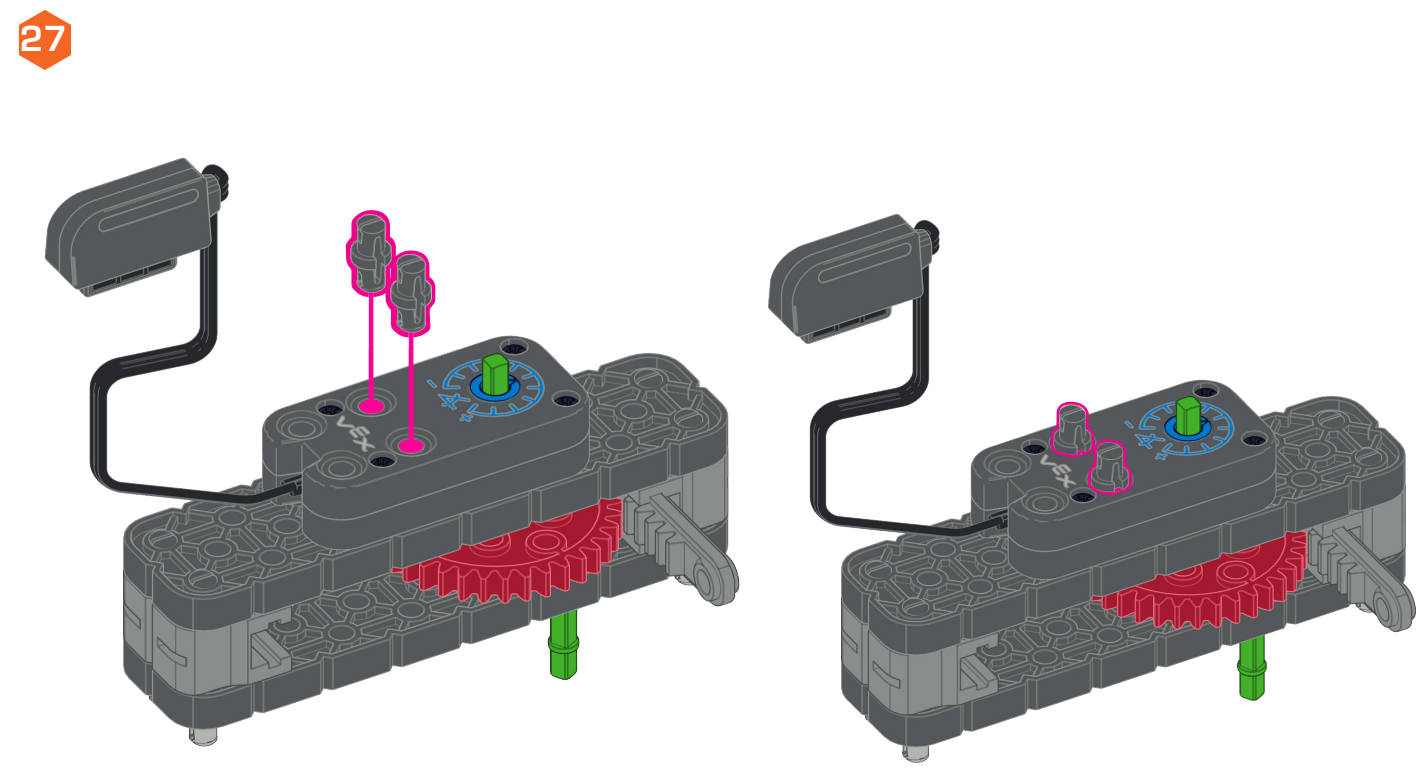
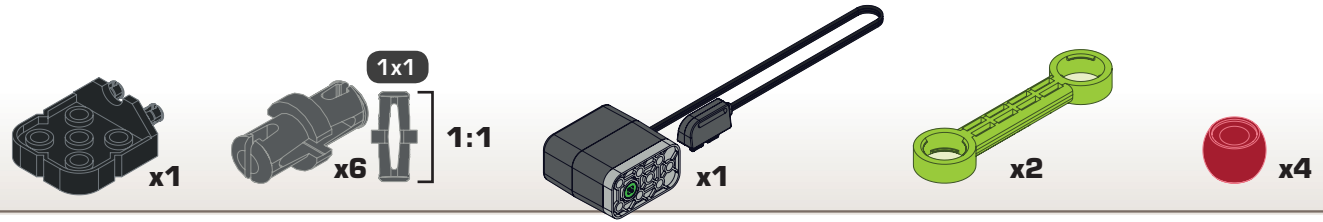



30

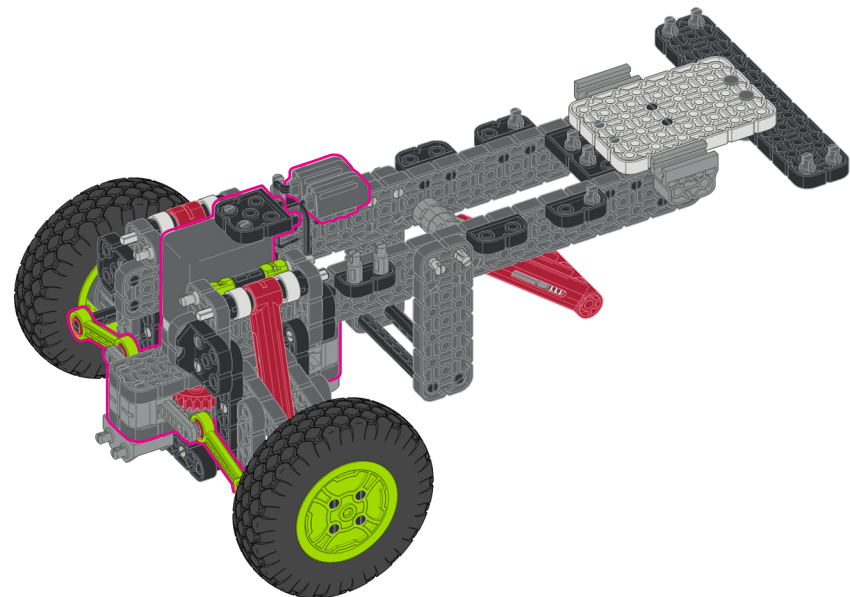
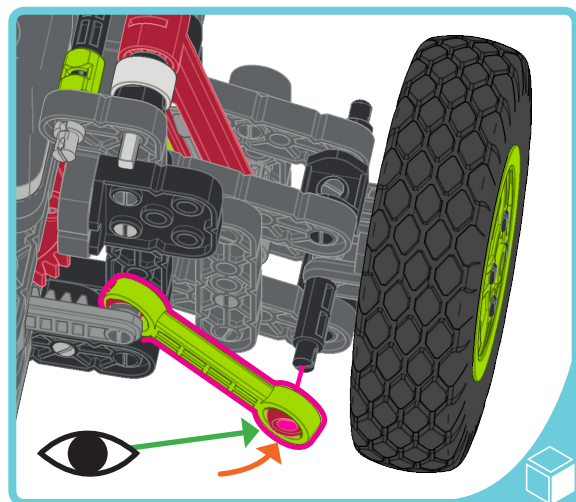
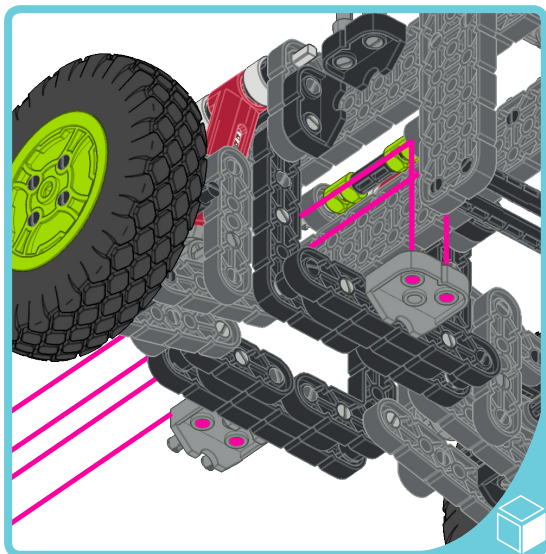
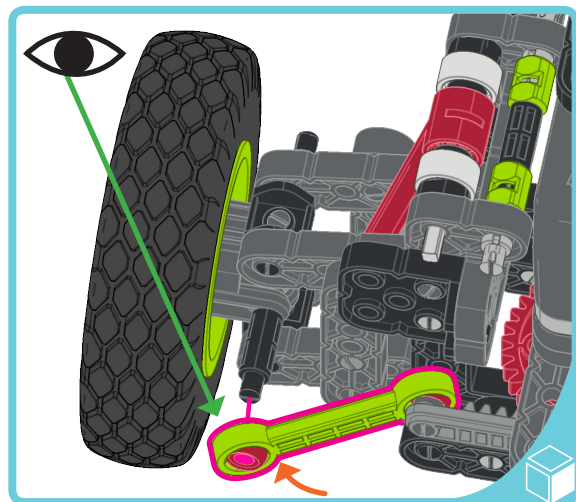
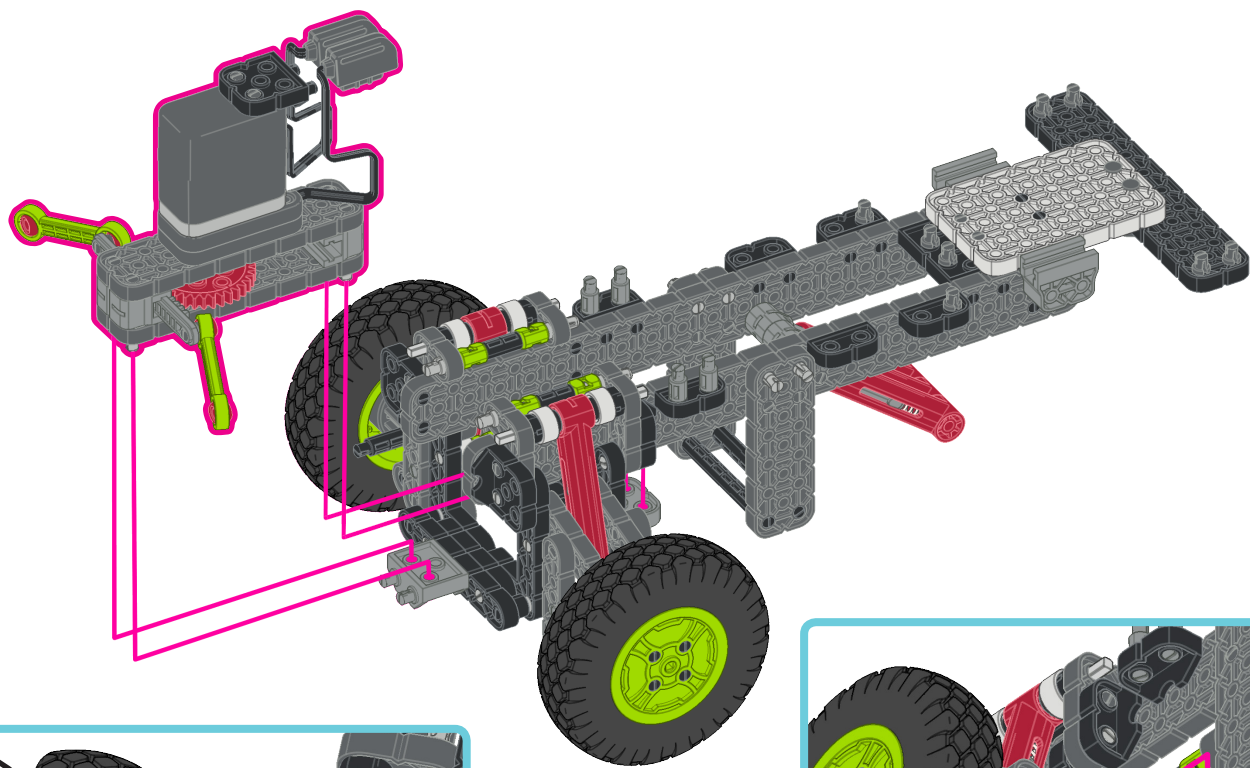

31

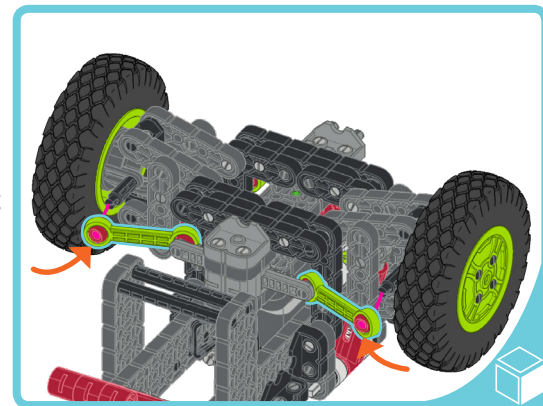
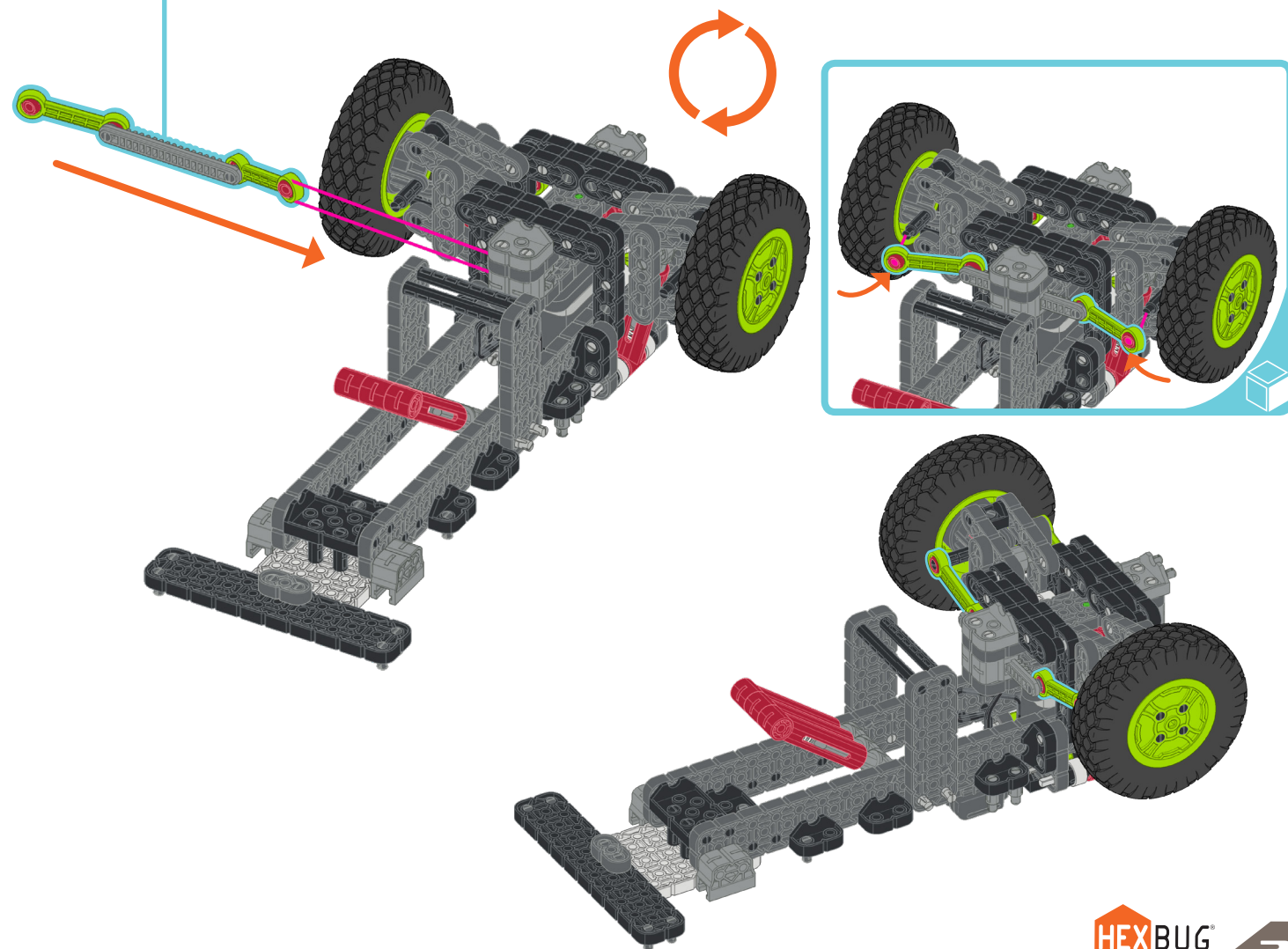
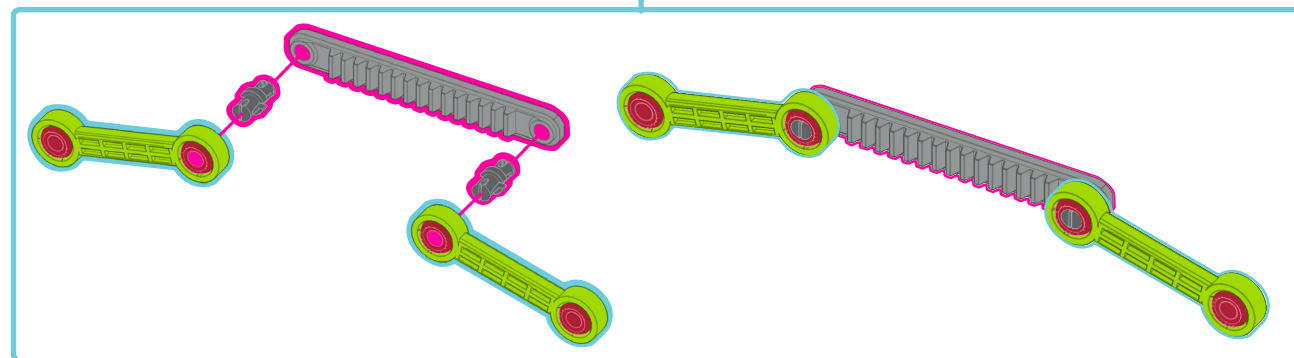
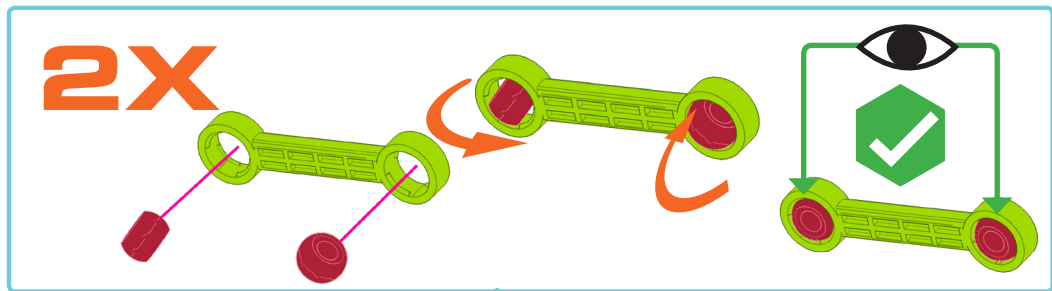

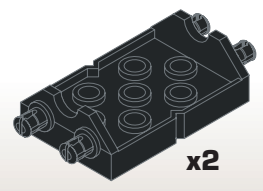
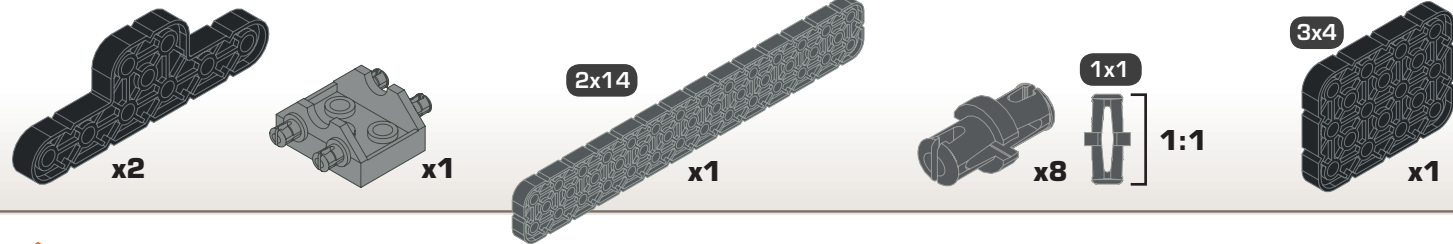

32

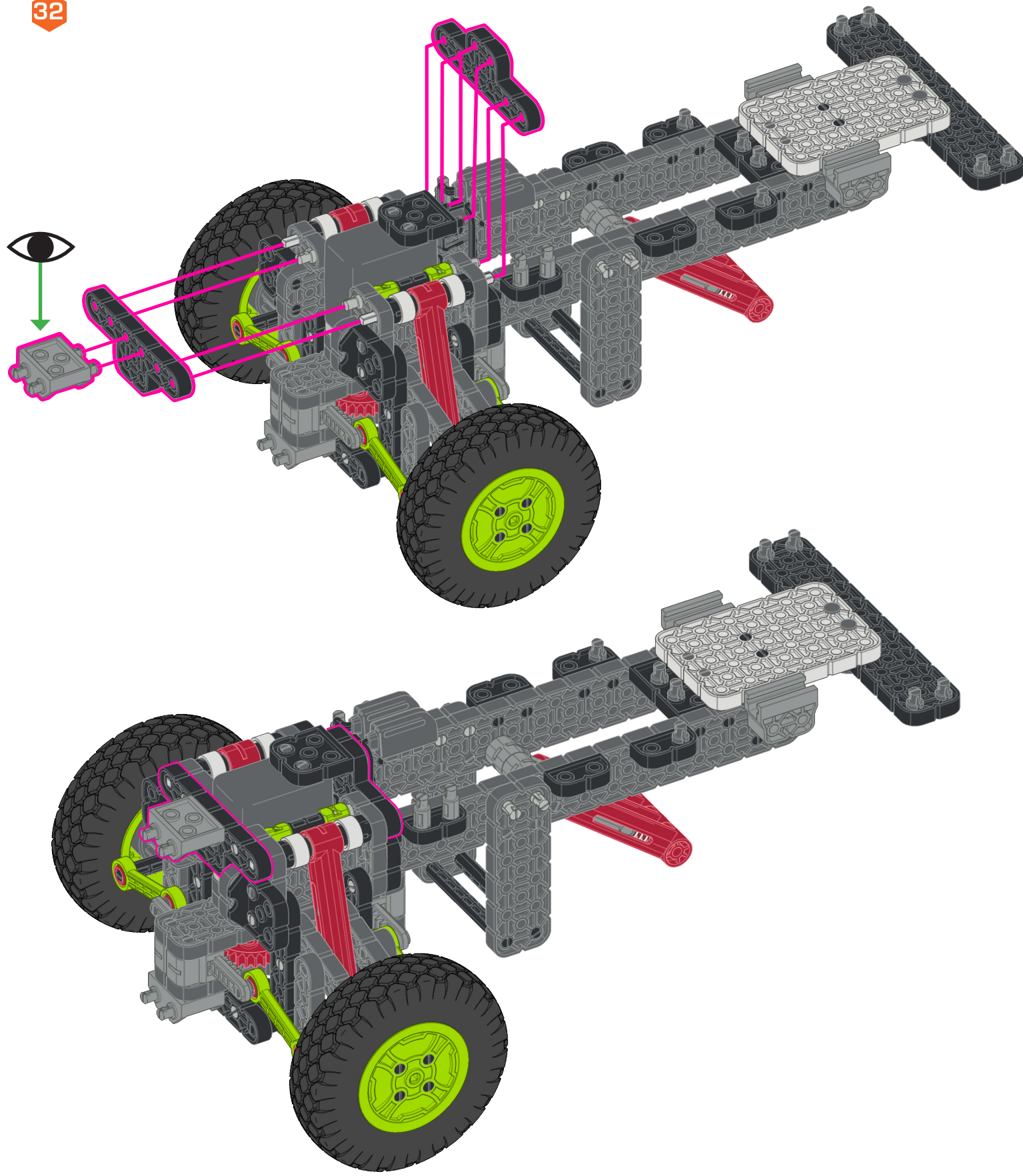

33

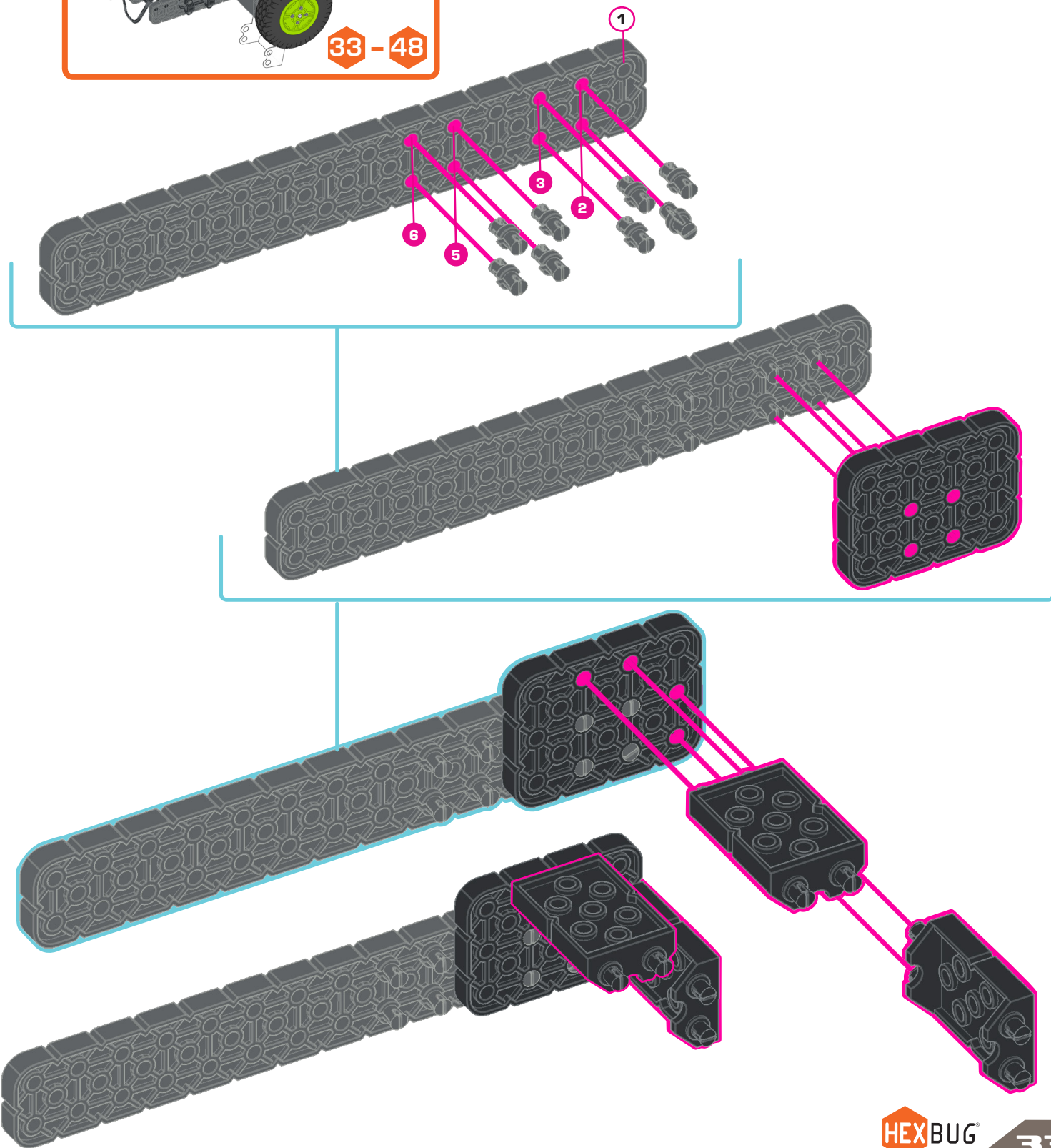
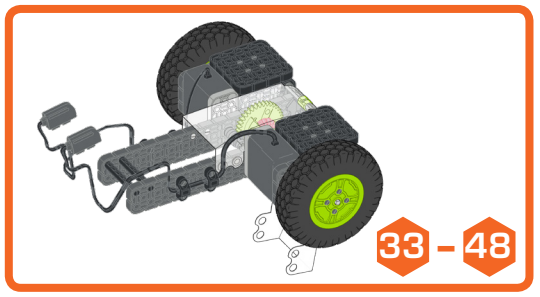

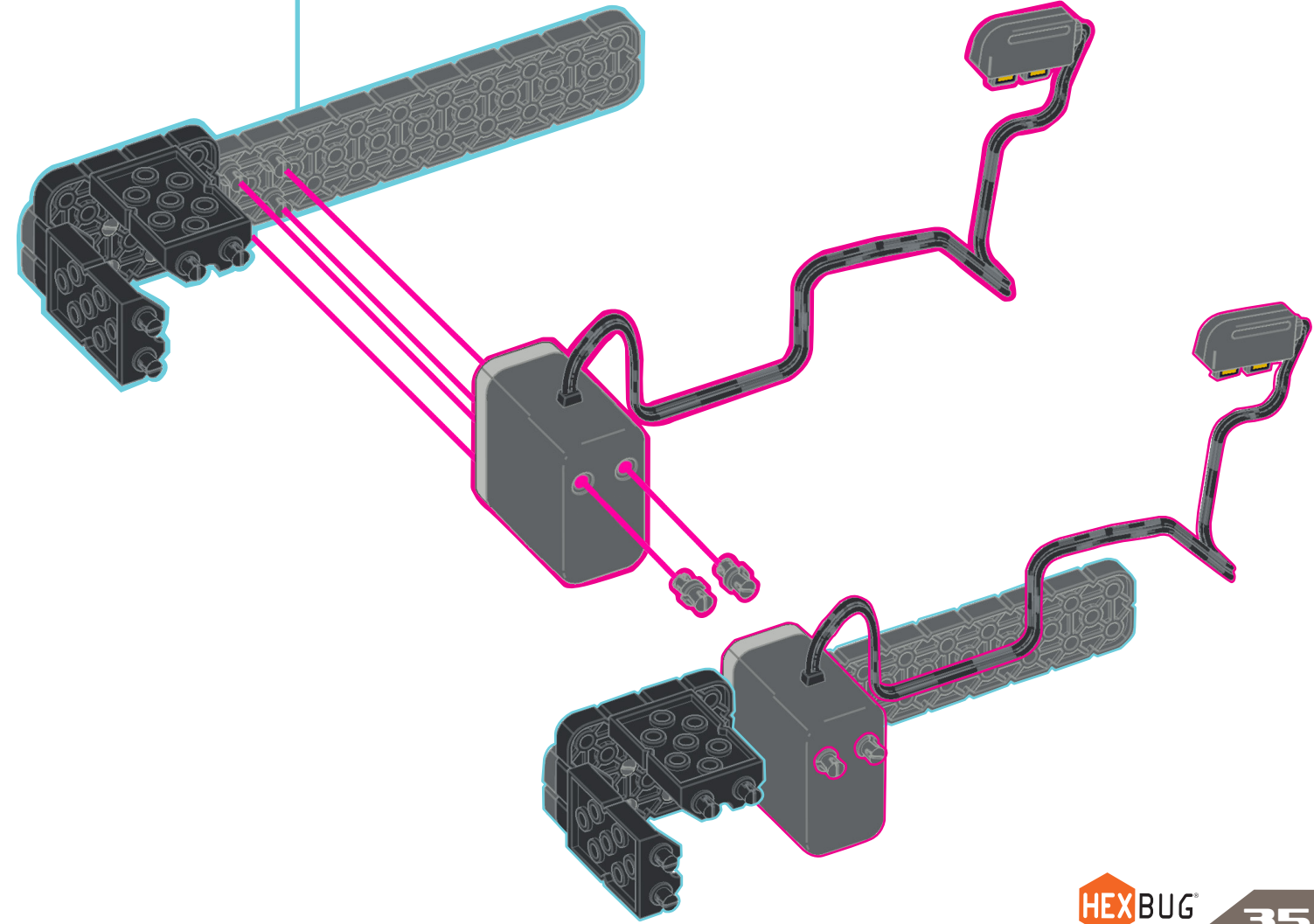
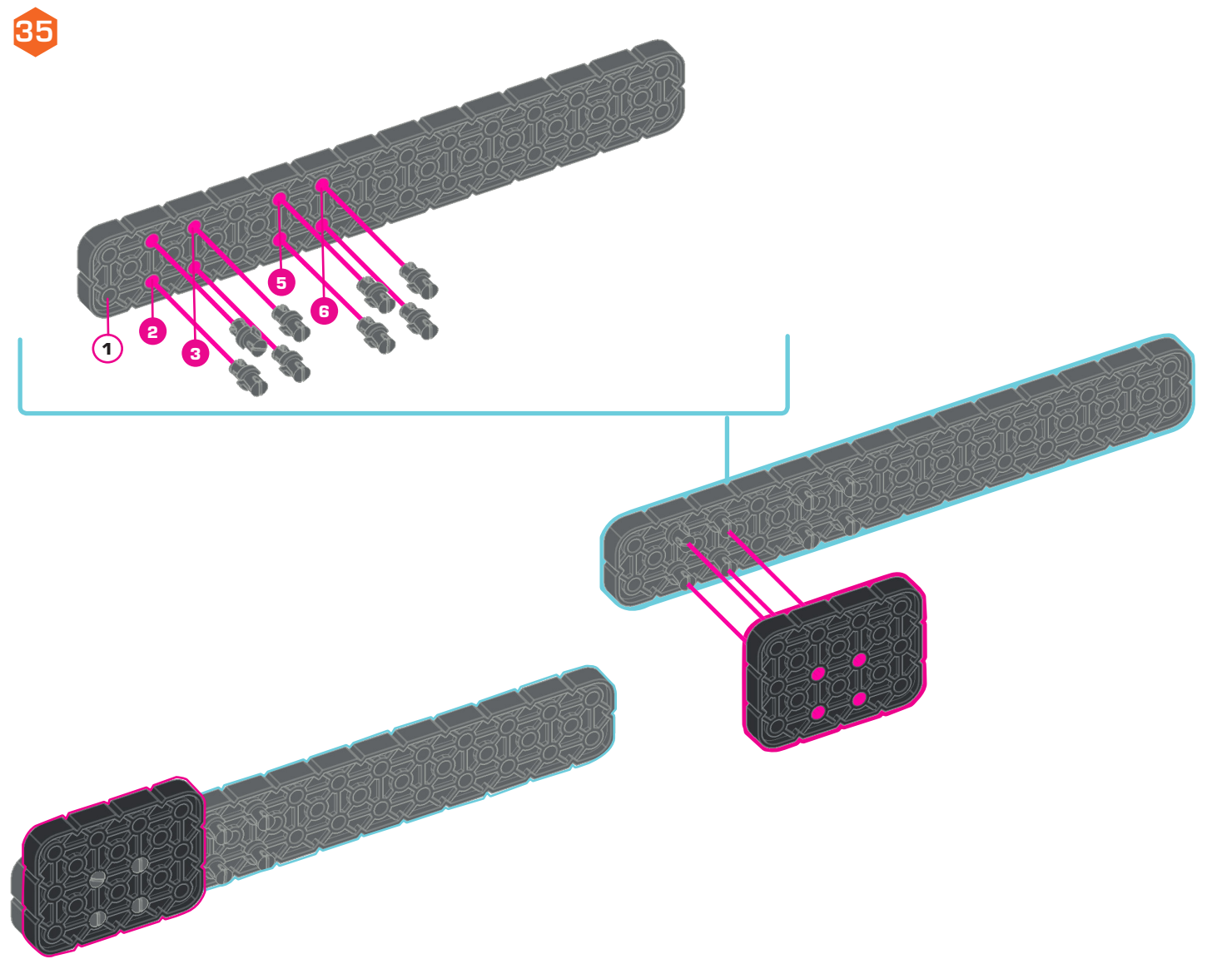
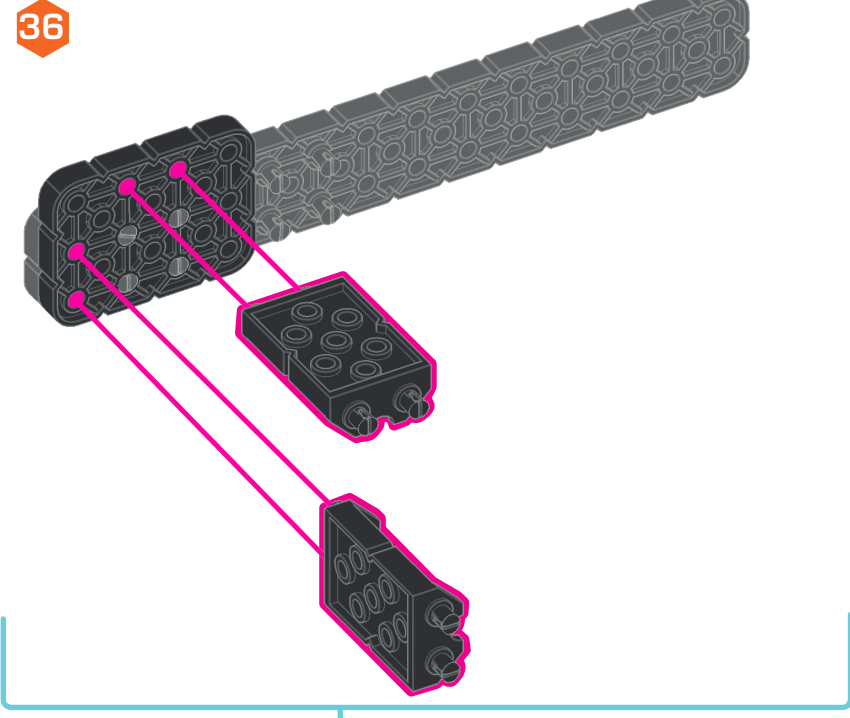
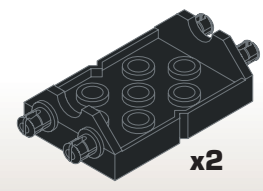
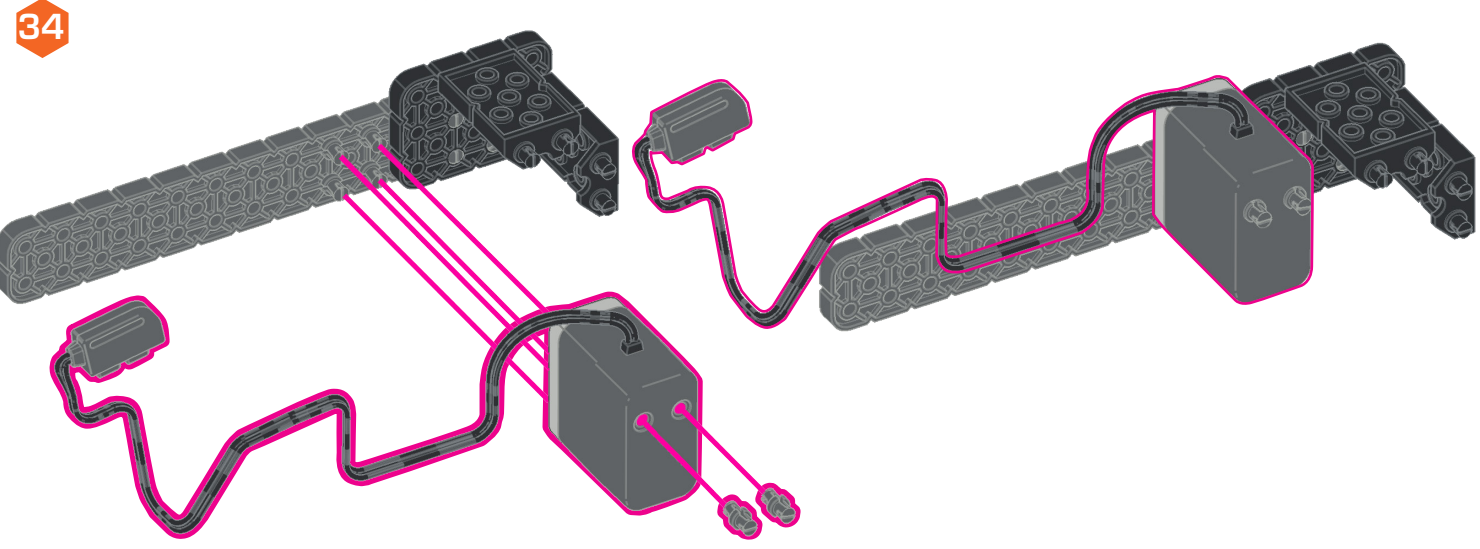
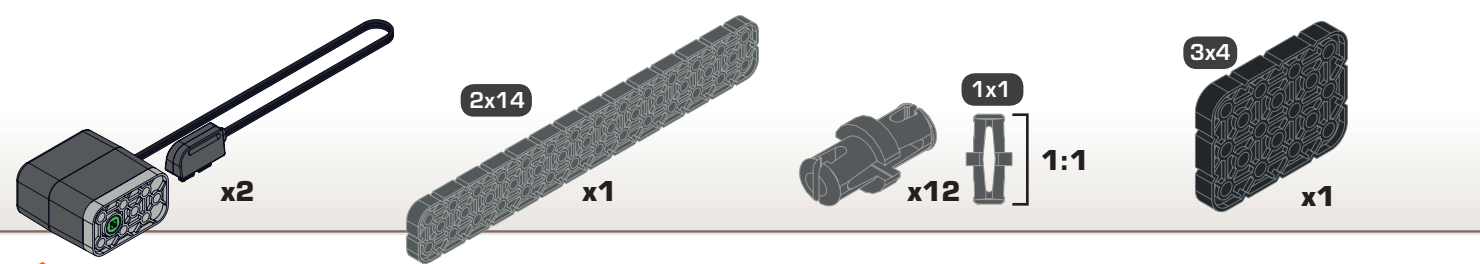

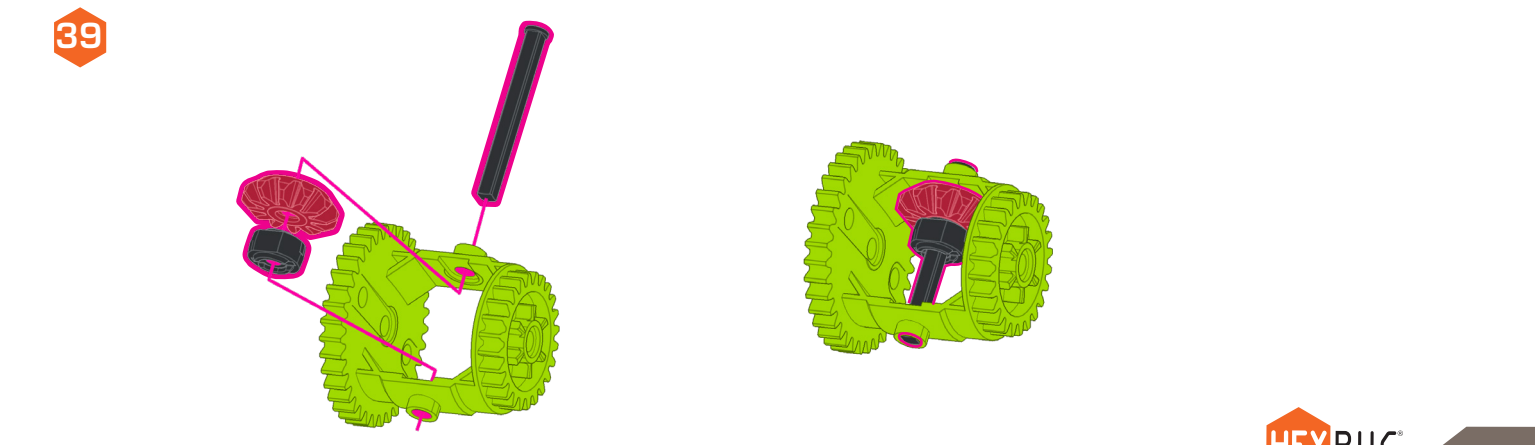
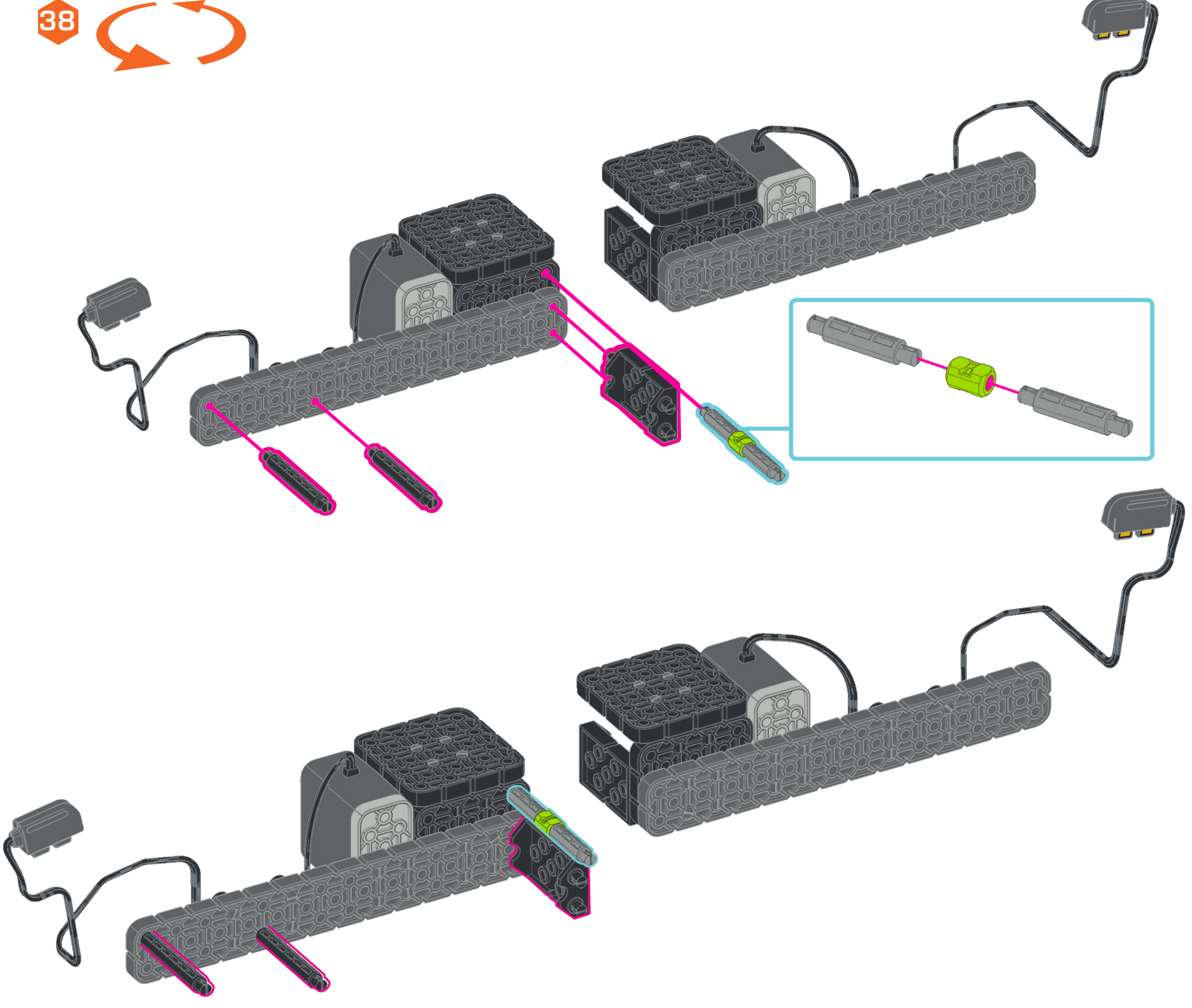
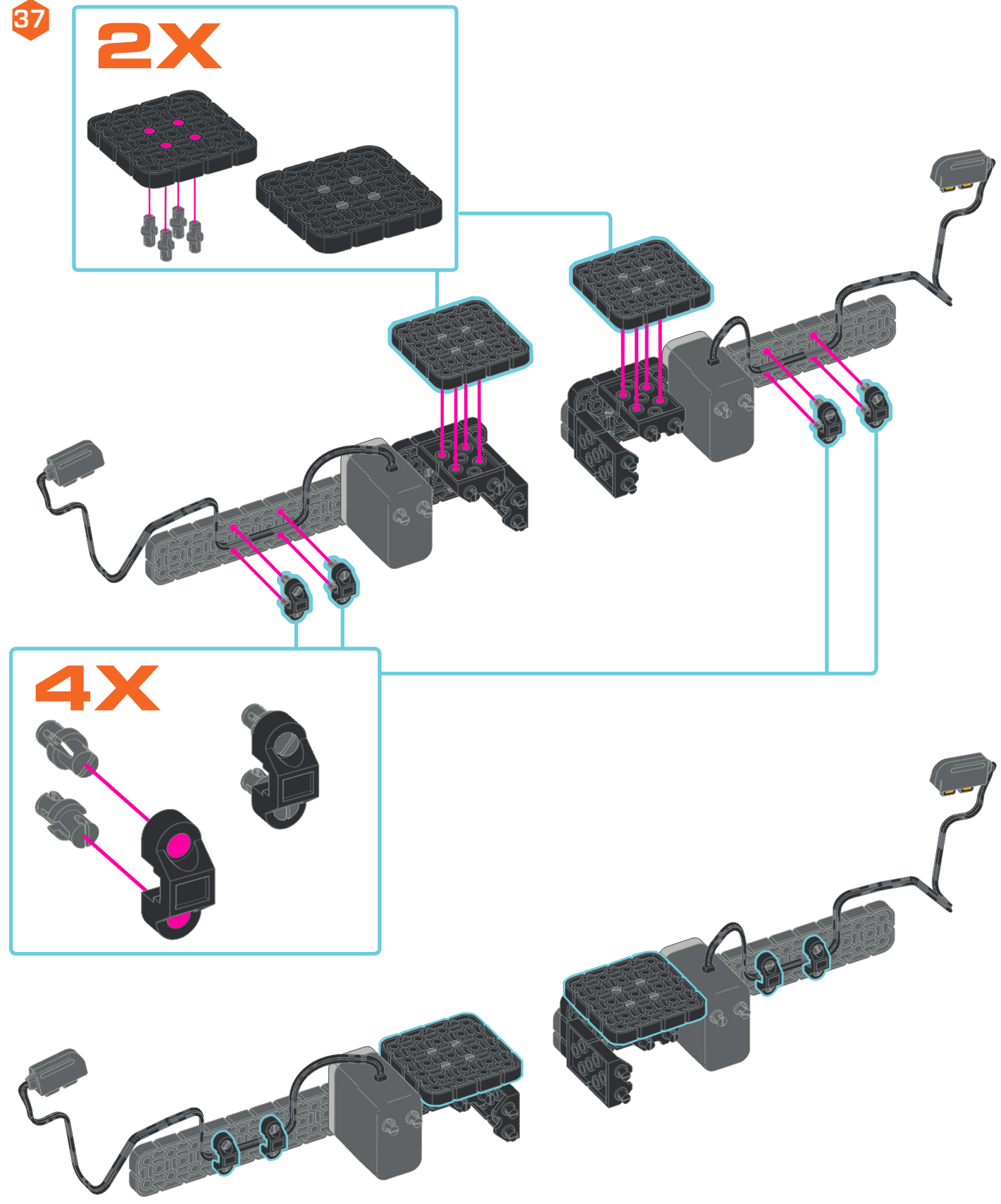
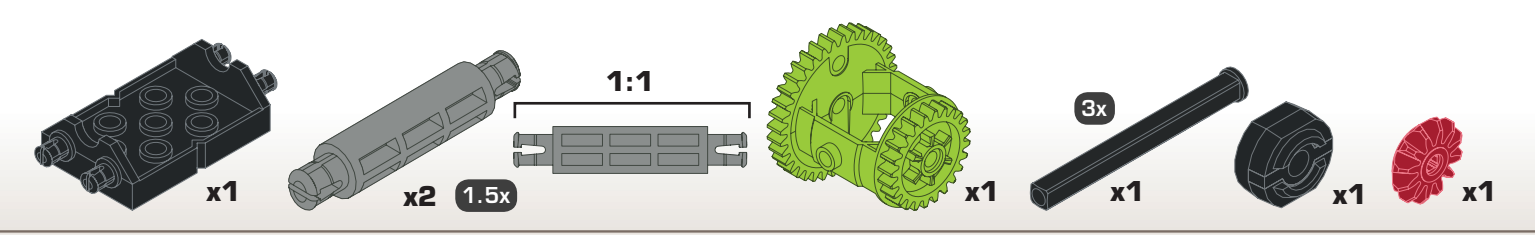
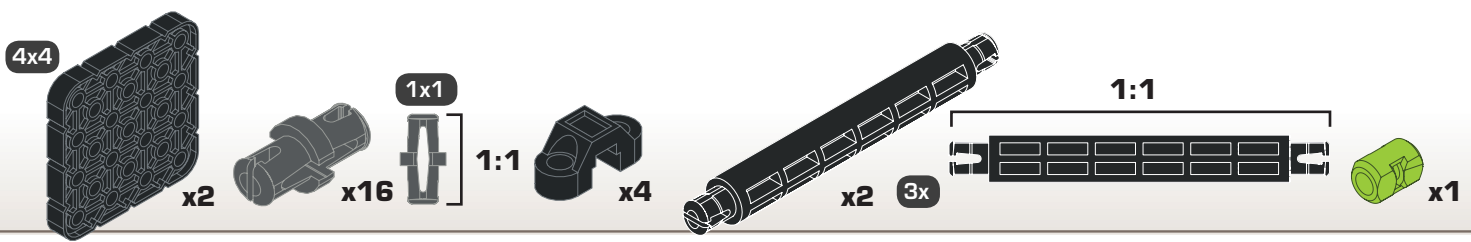

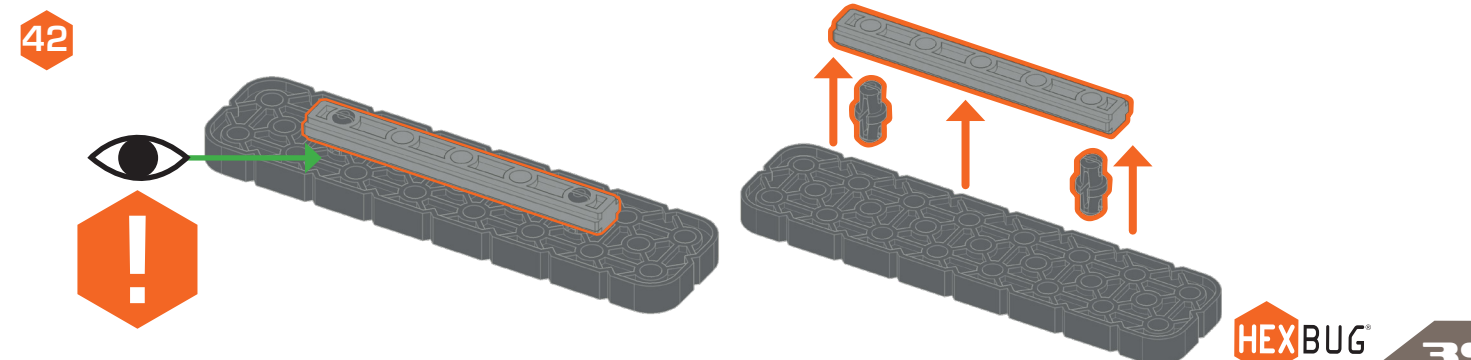
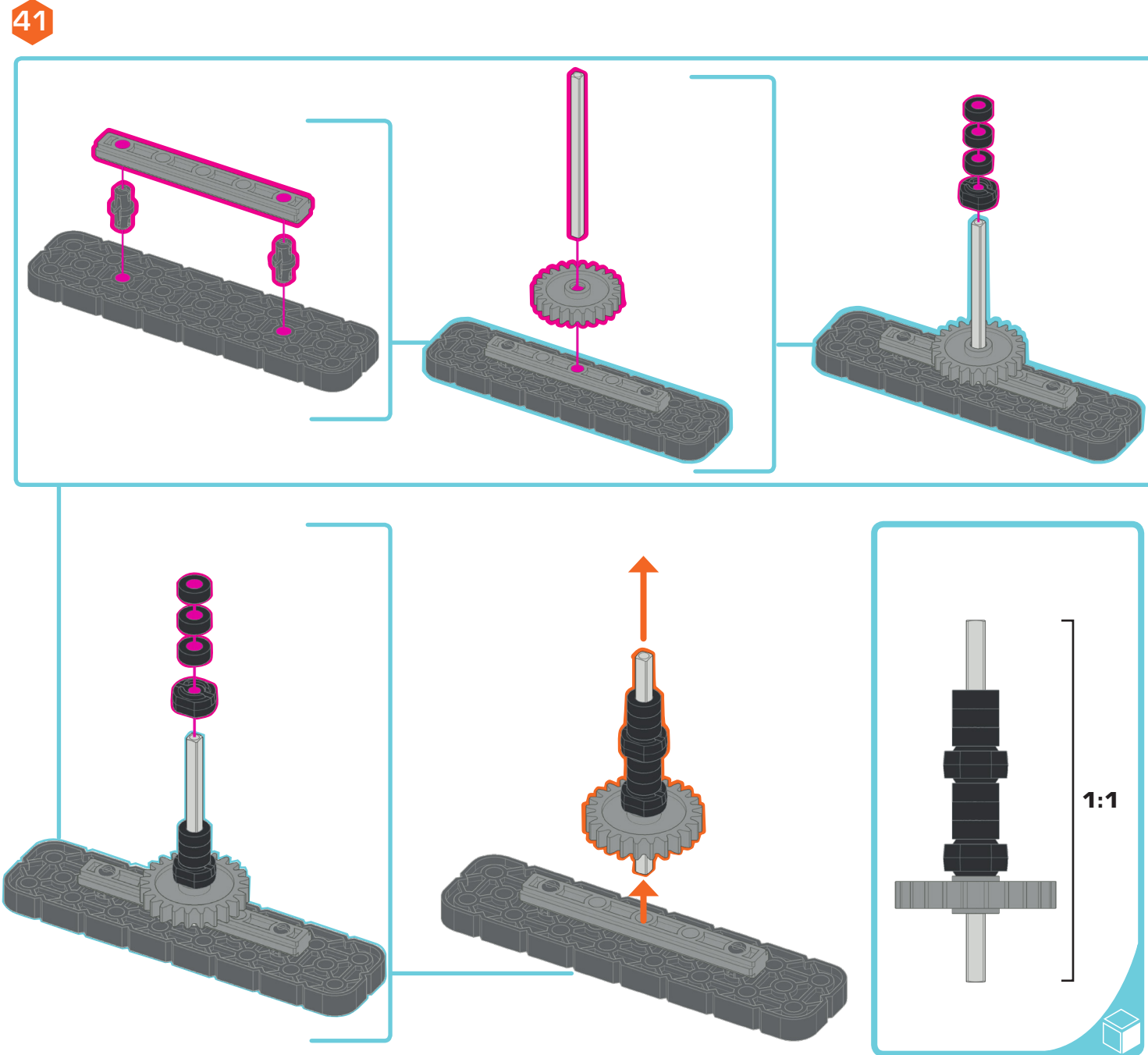
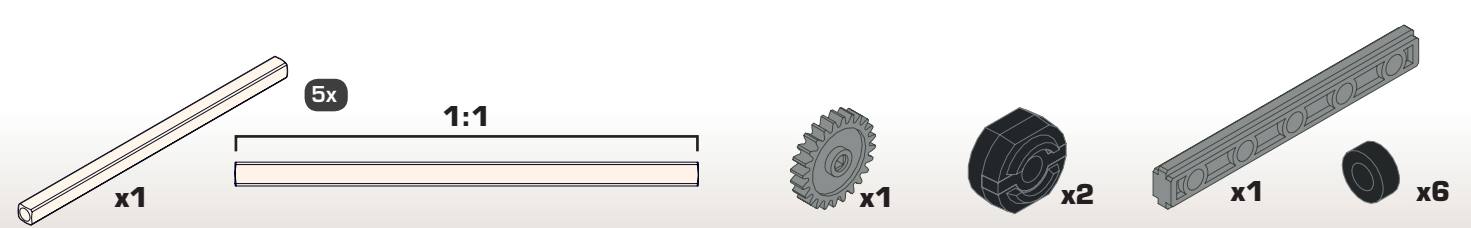
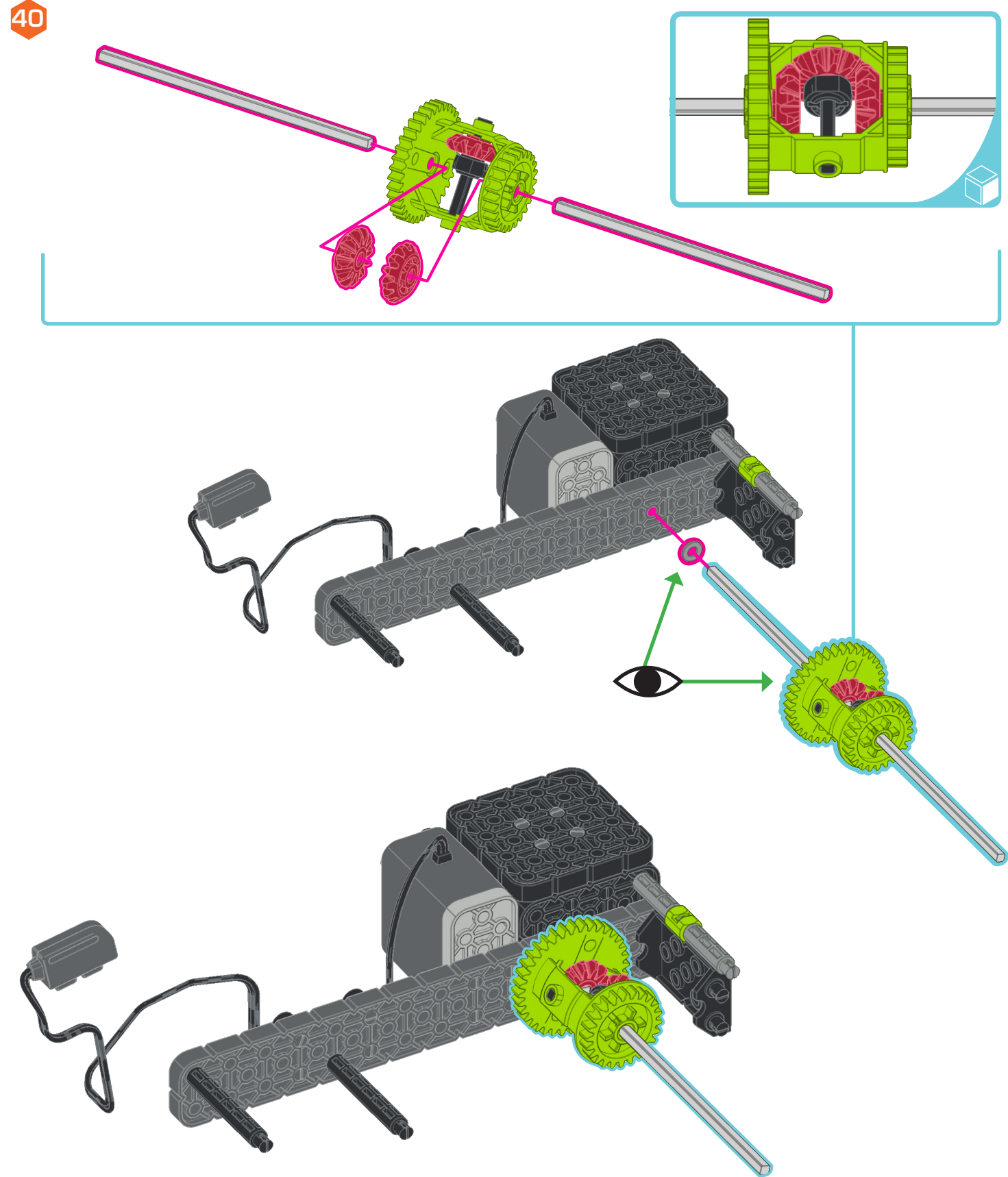
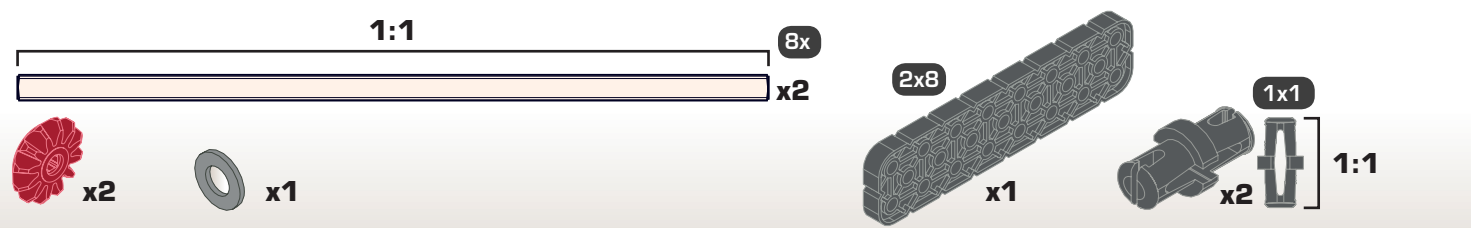

○ x3

43

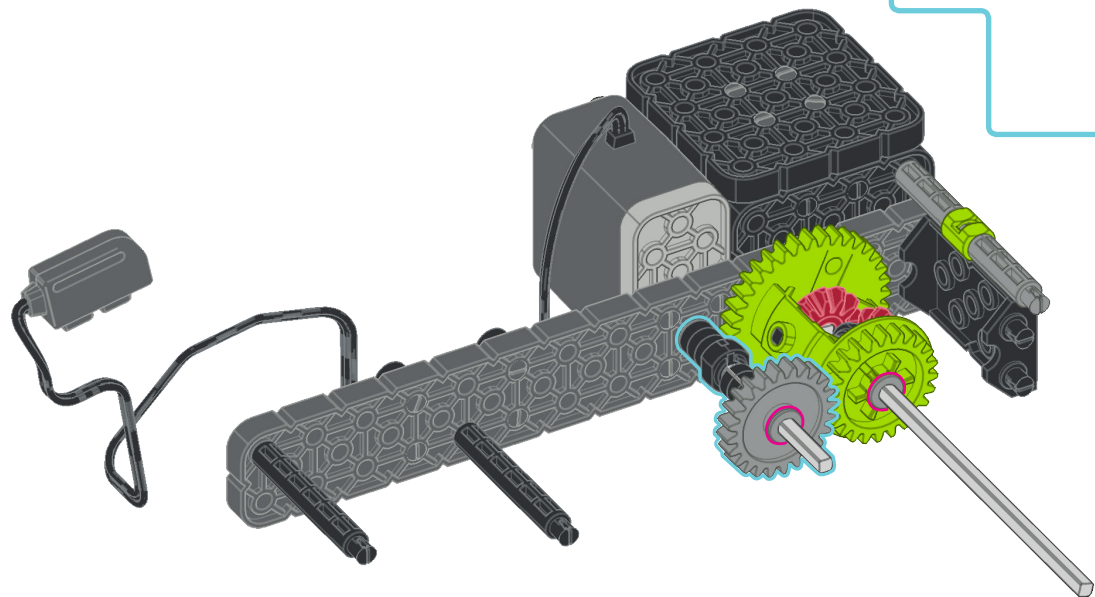
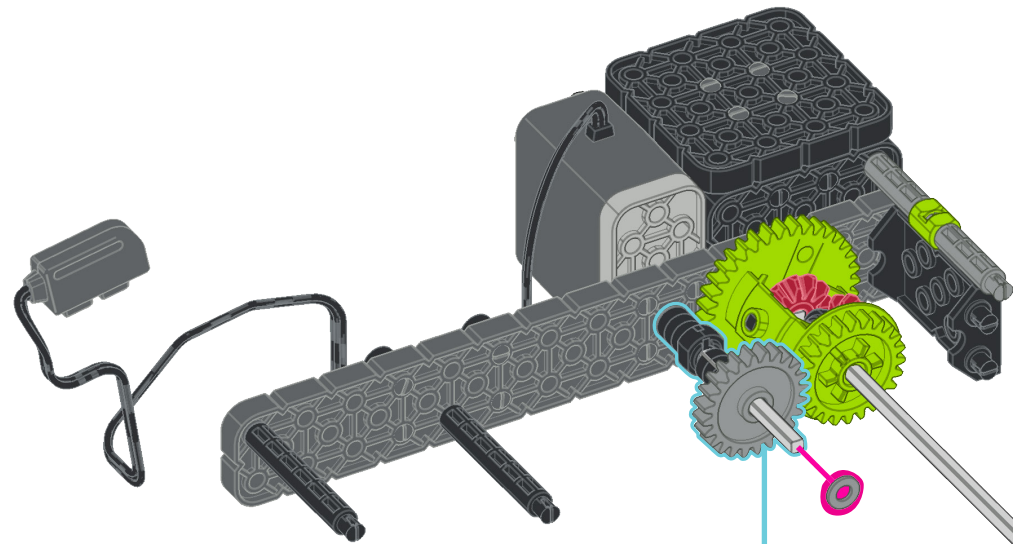
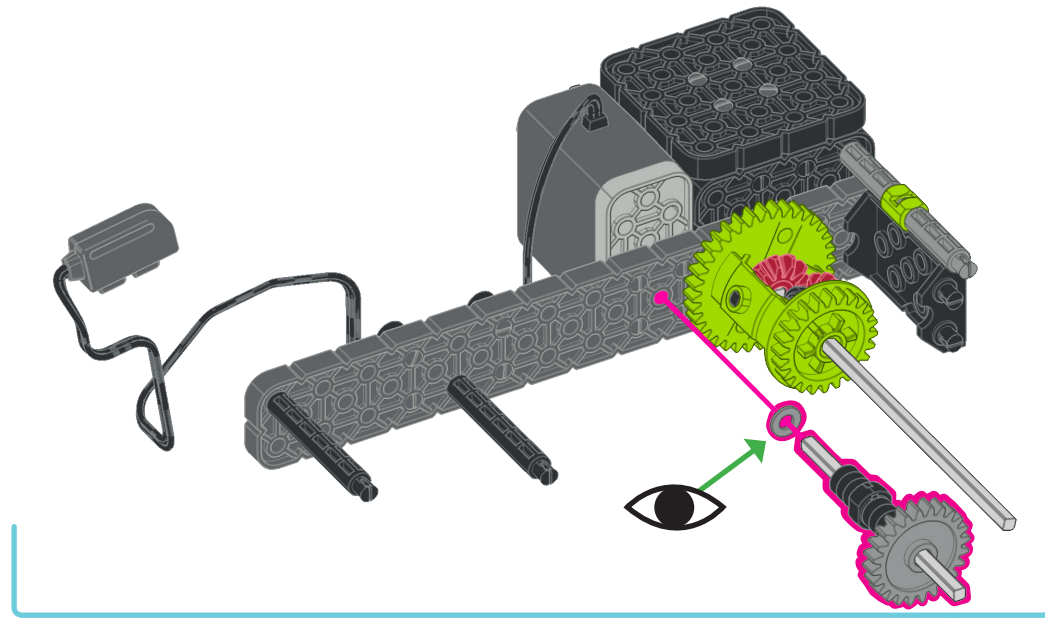

44

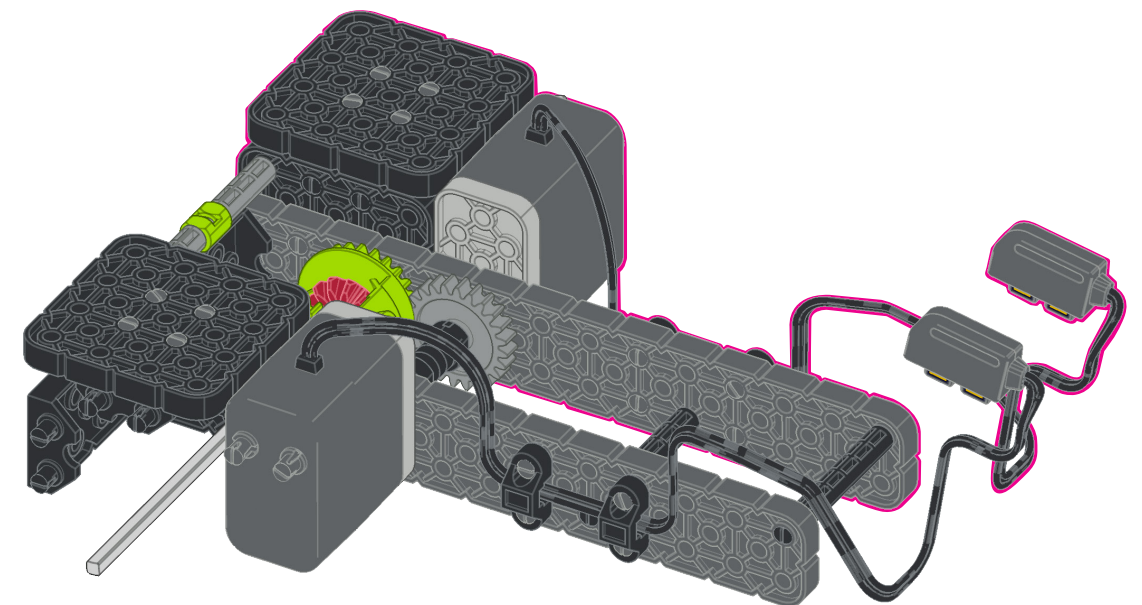
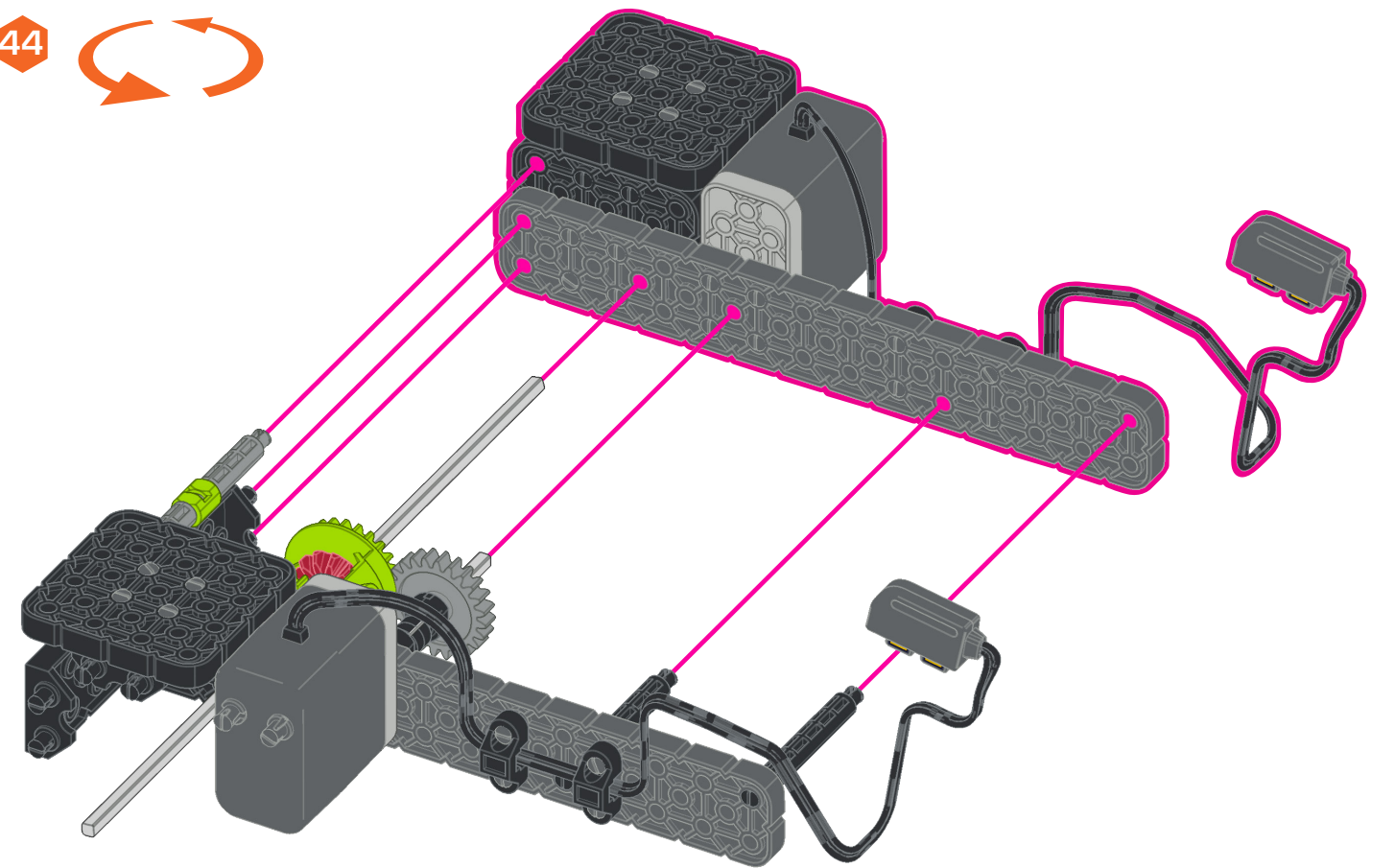



x4

3x6

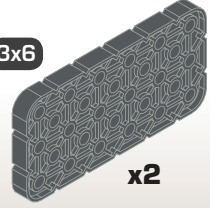

x2



x3



x1

45

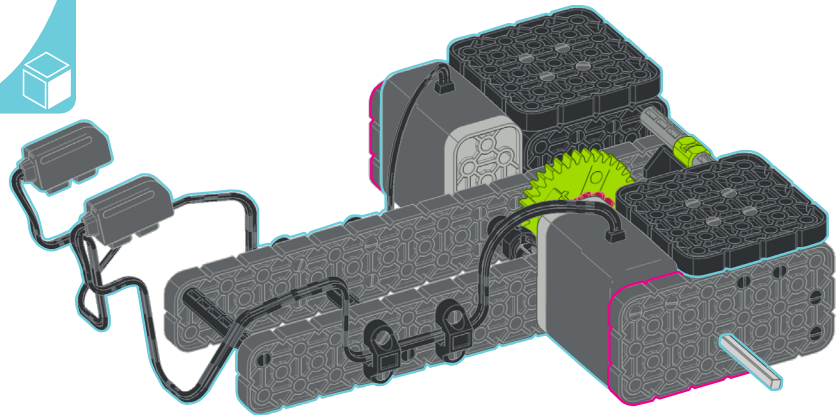
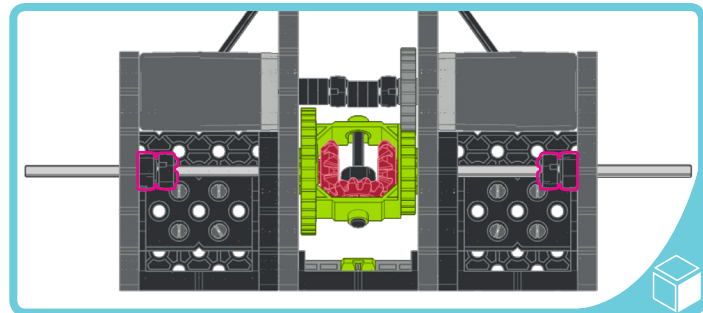
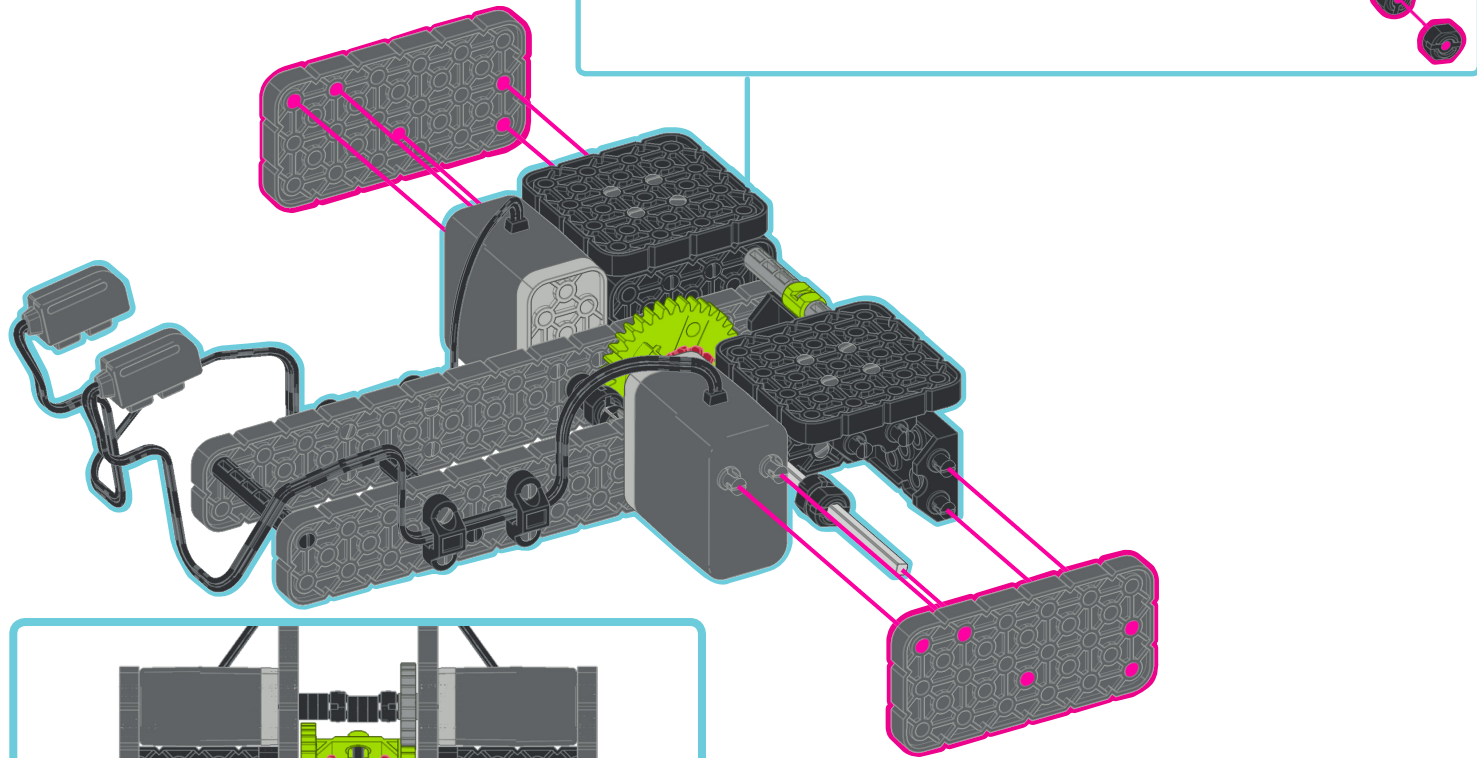
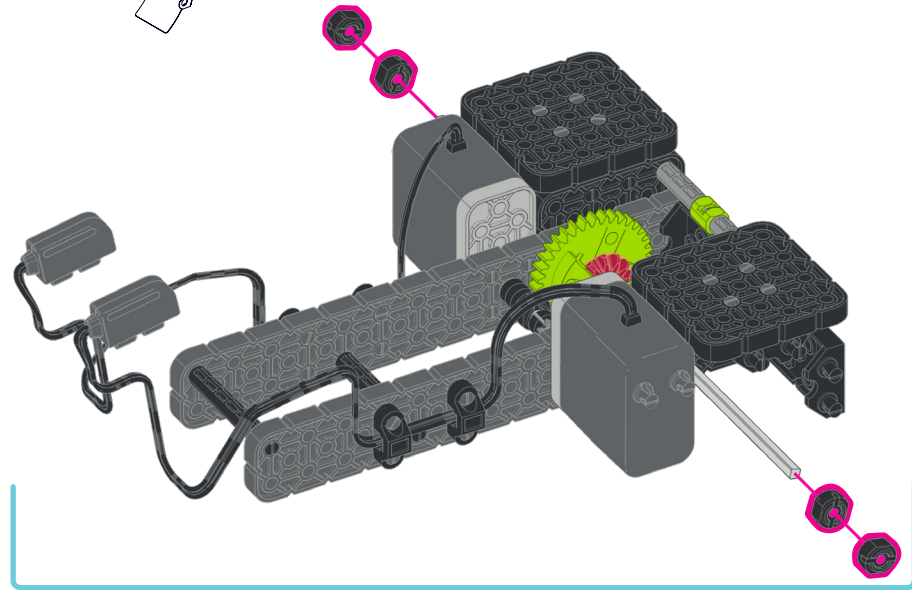

46

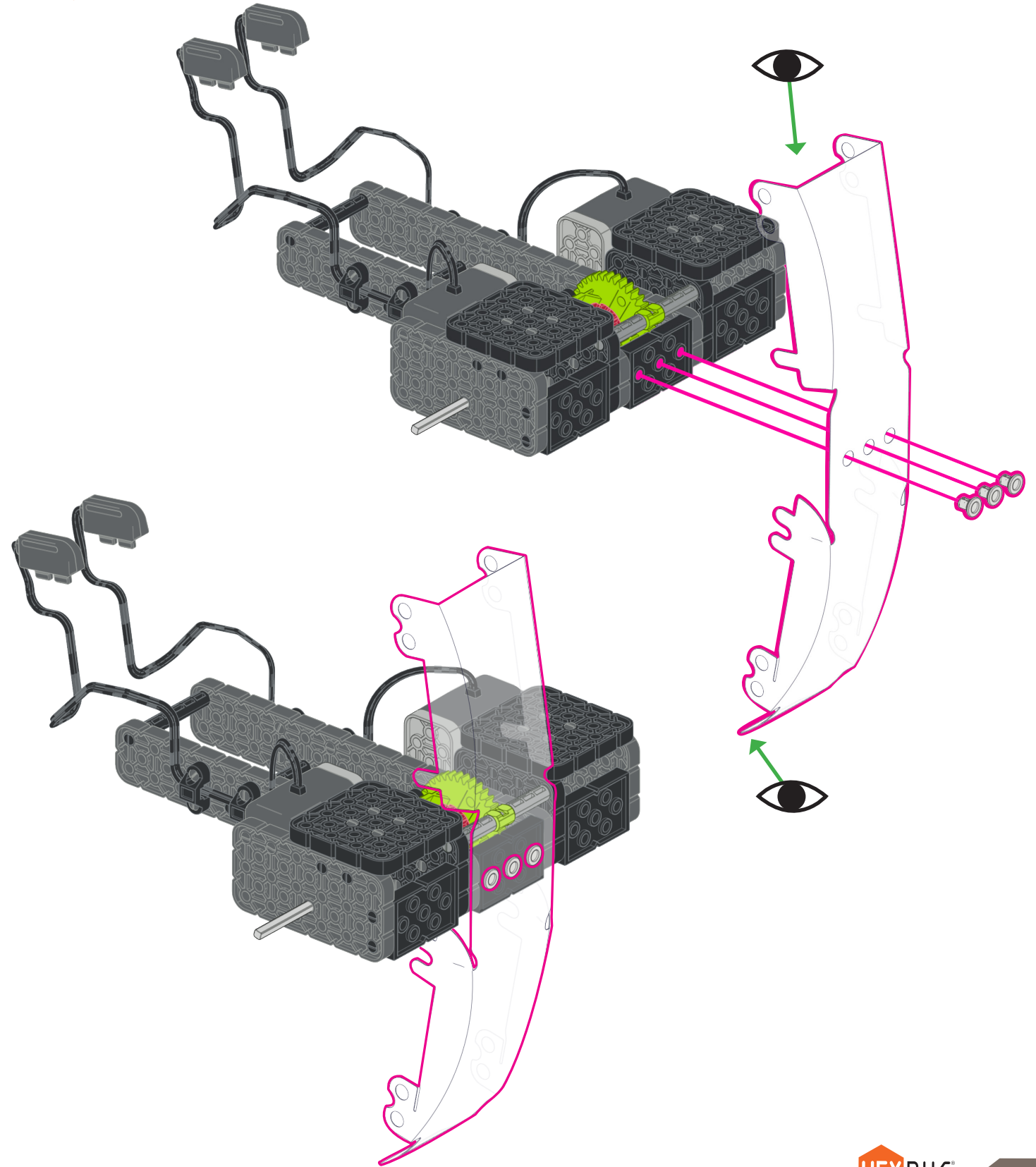

x4

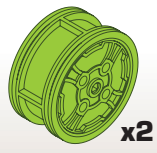

x2



x2

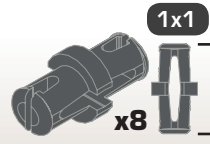

1x1

1:1



x2



x2



x2



x2

47

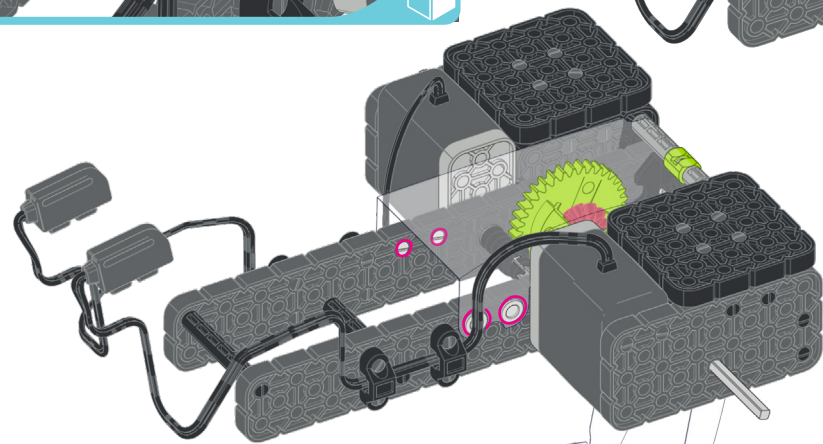
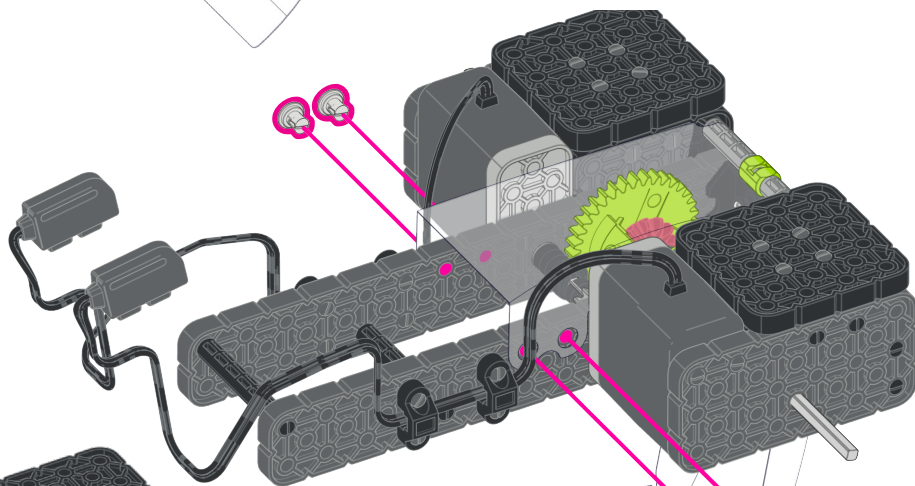
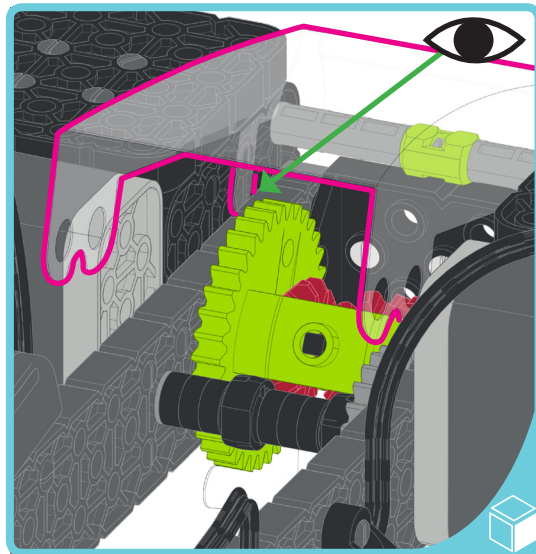
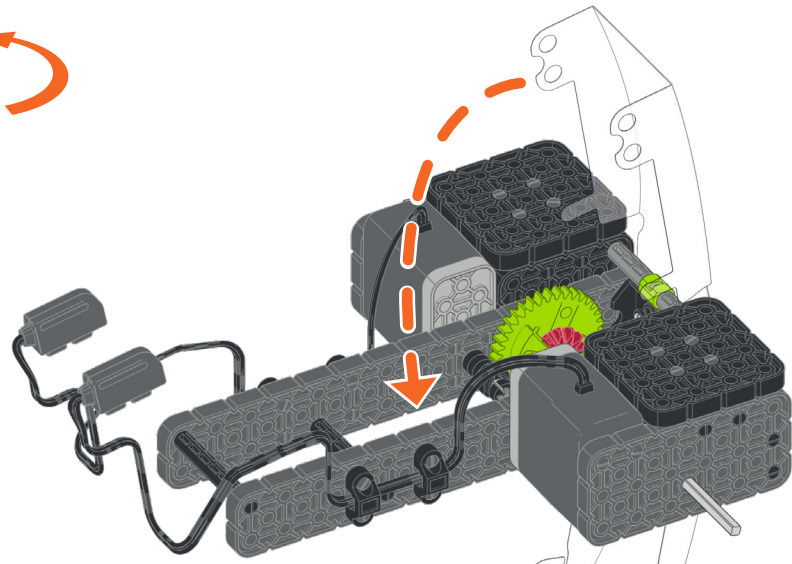

48

2X

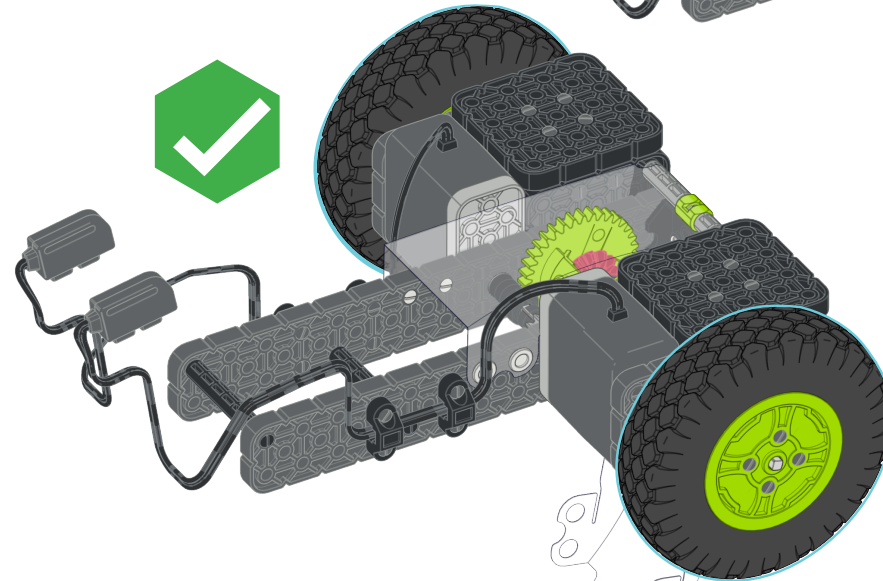
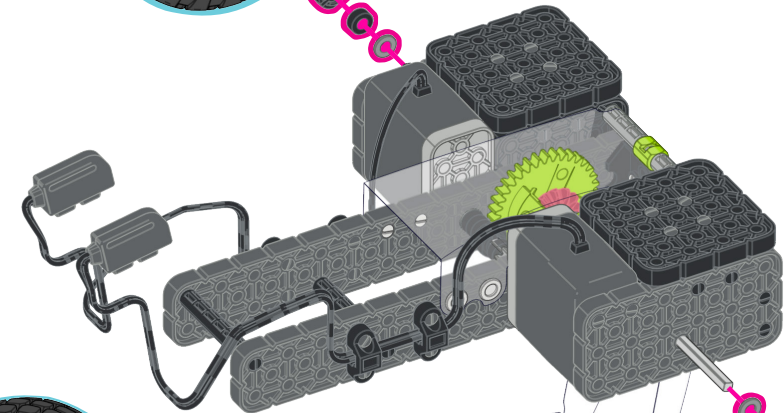
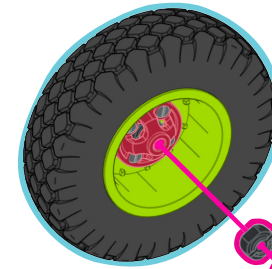
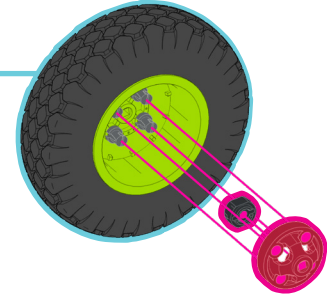
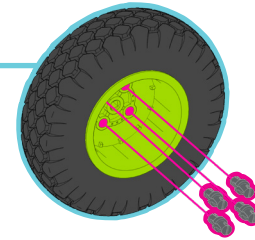
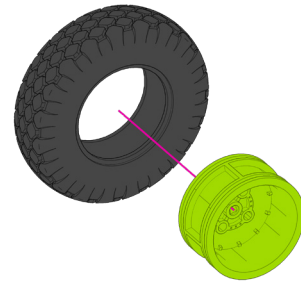

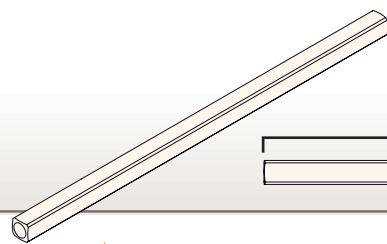

1:1

6x

x1



x2

49

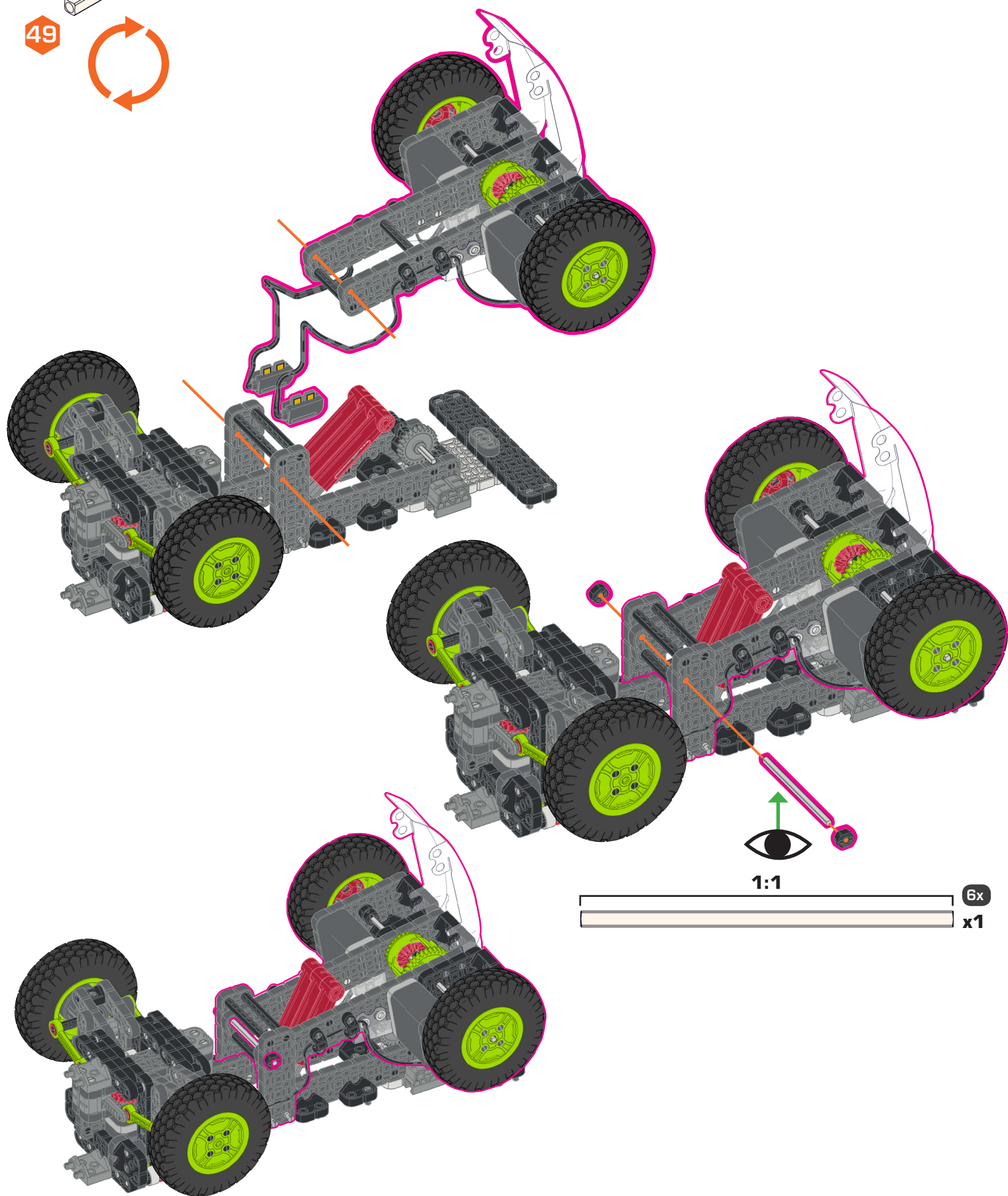

1:1

6x

x1

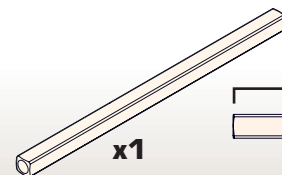

x1

5x

1:1

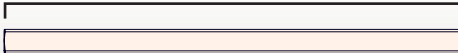

50

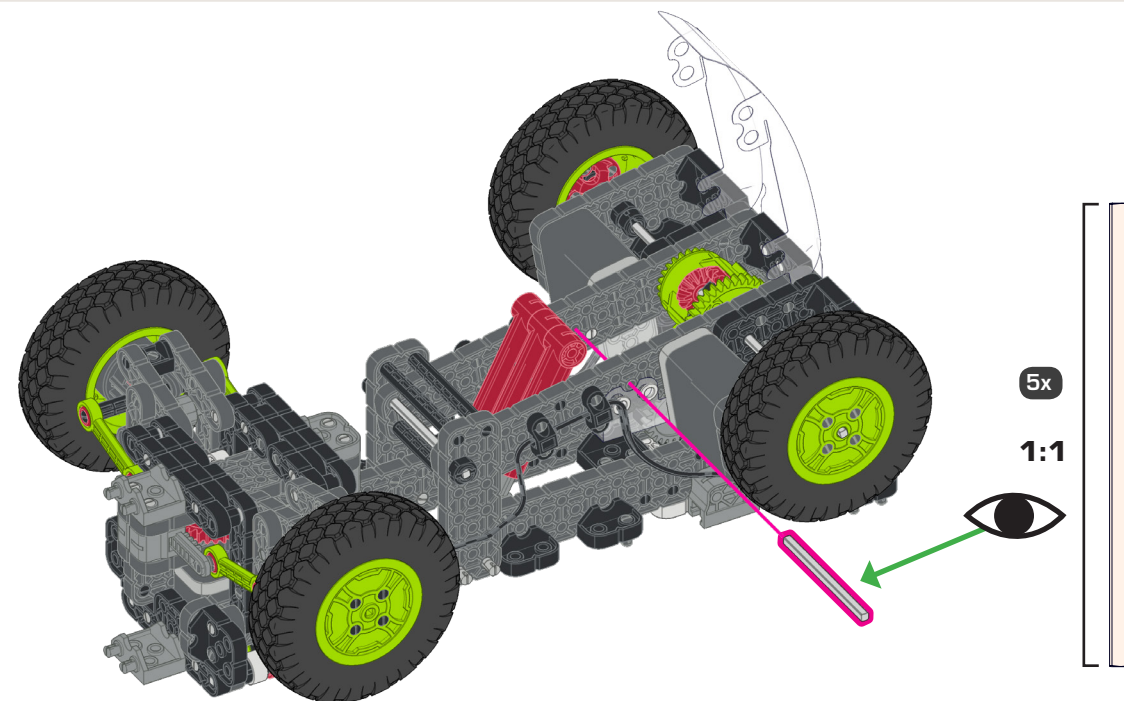

5x

1:1

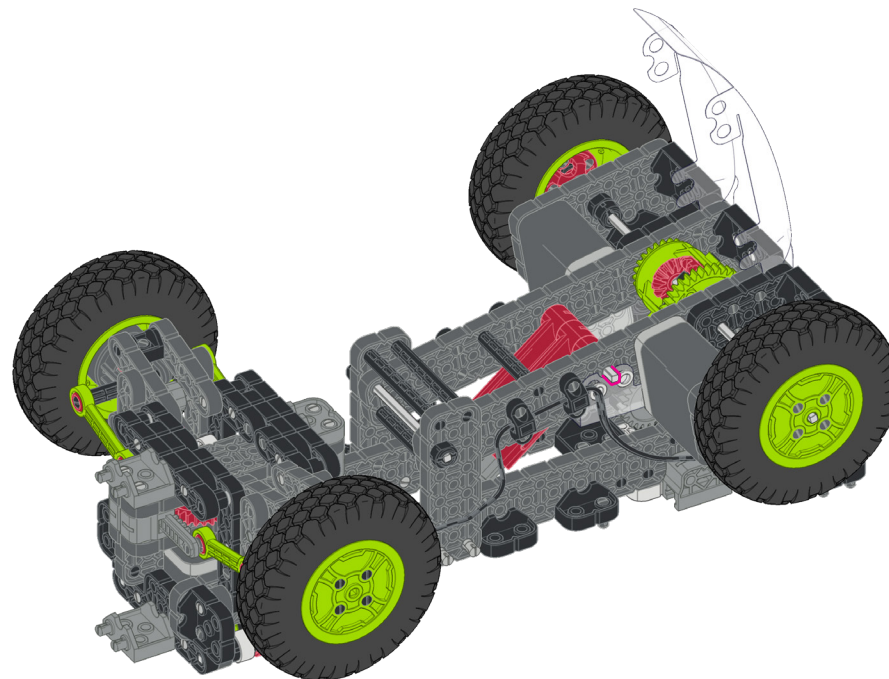
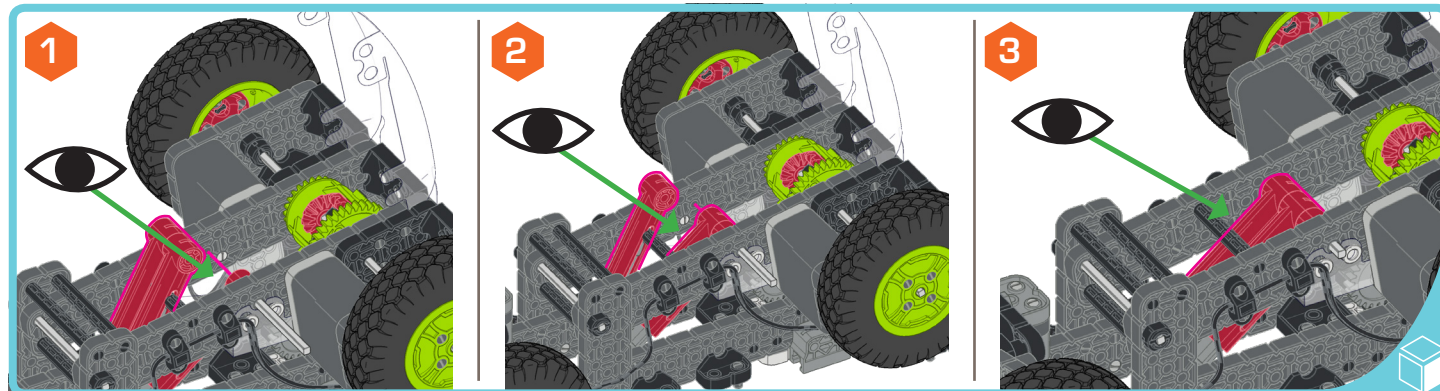



x2

51

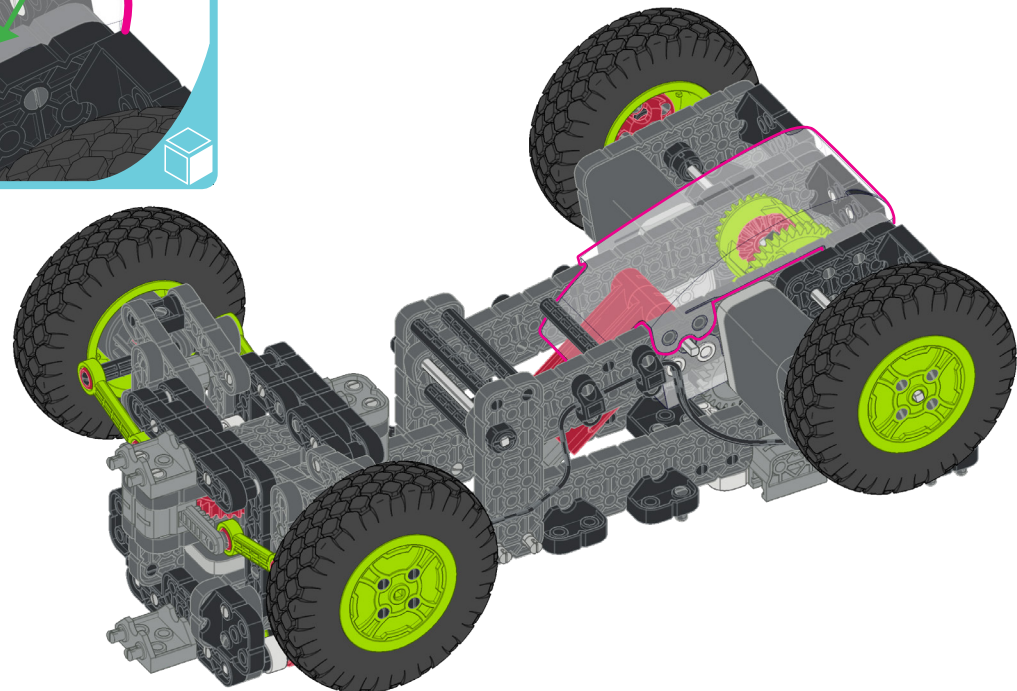
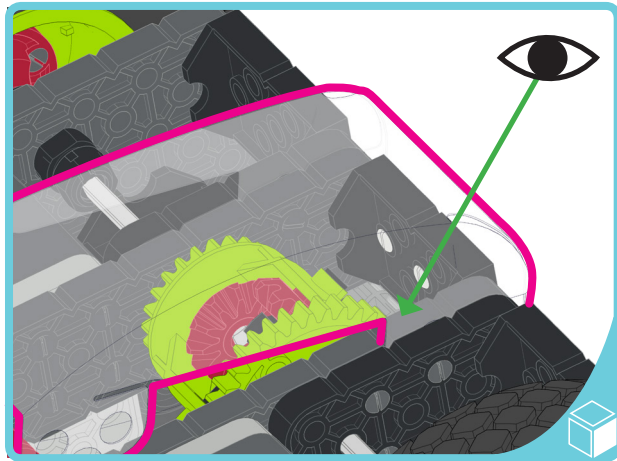
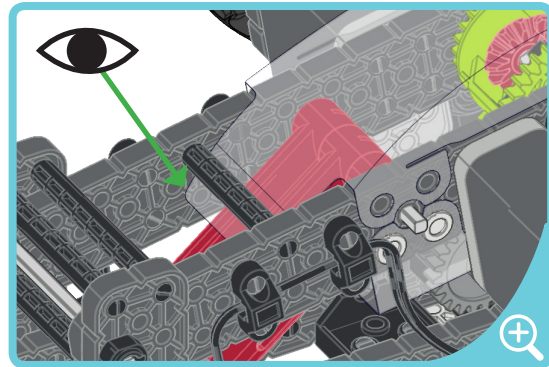
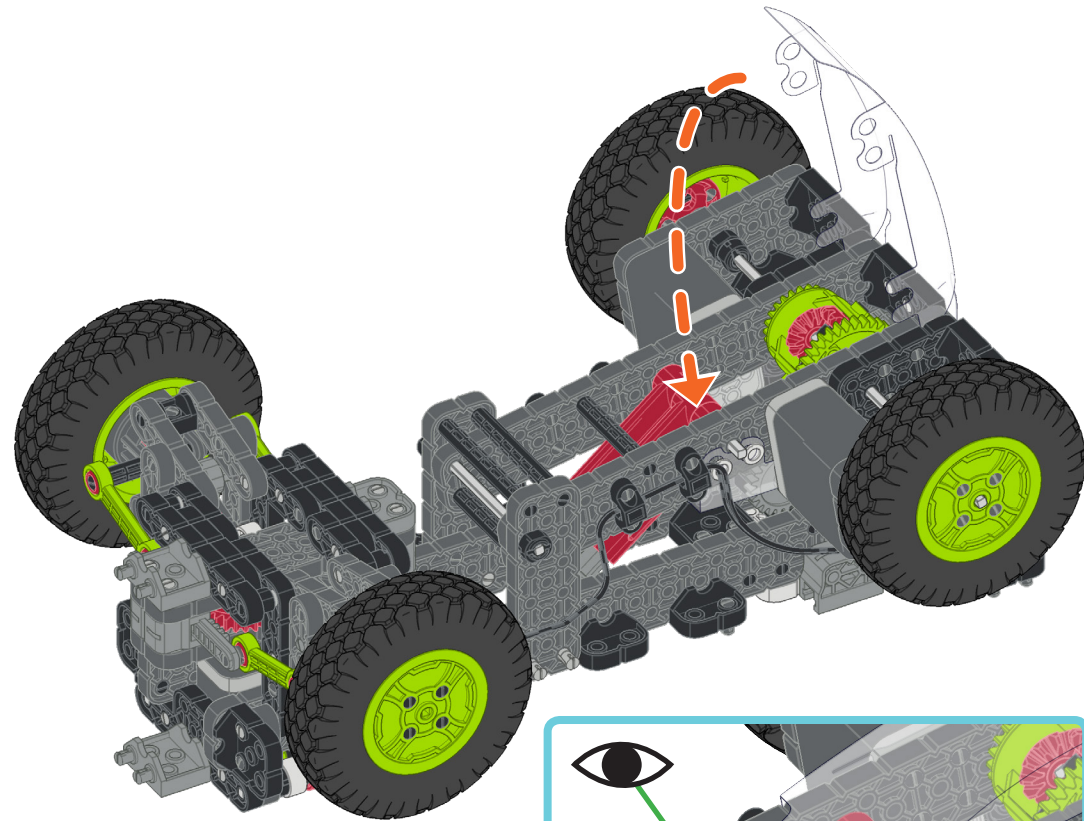

52

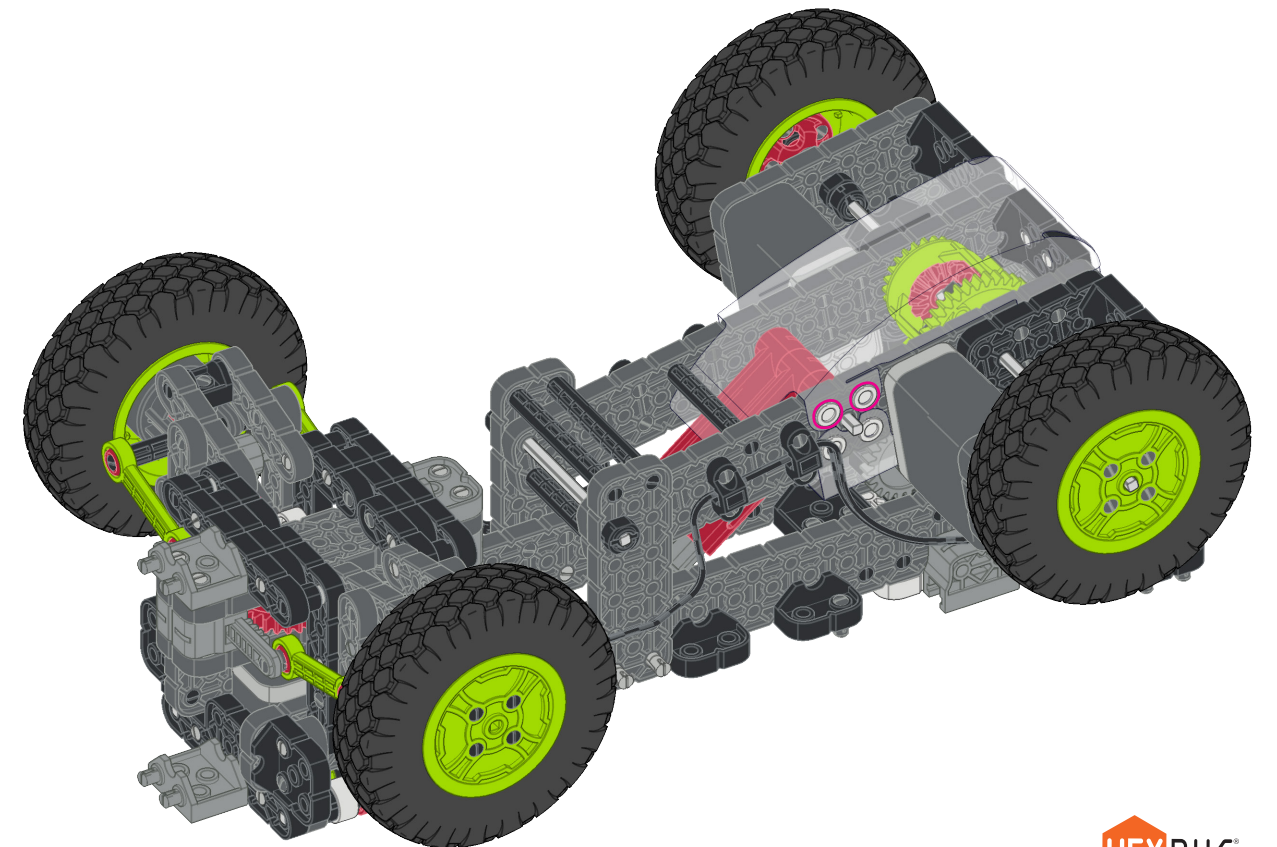
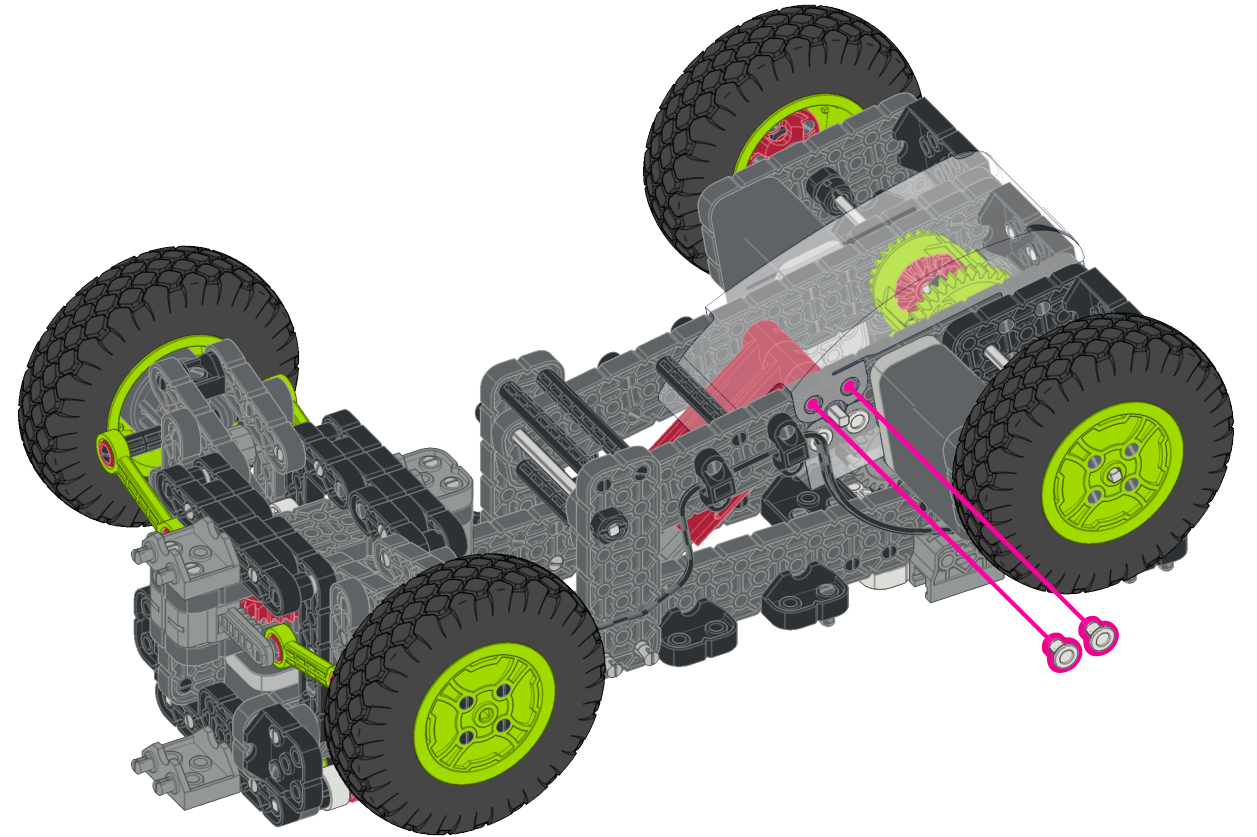



x1



x2

53

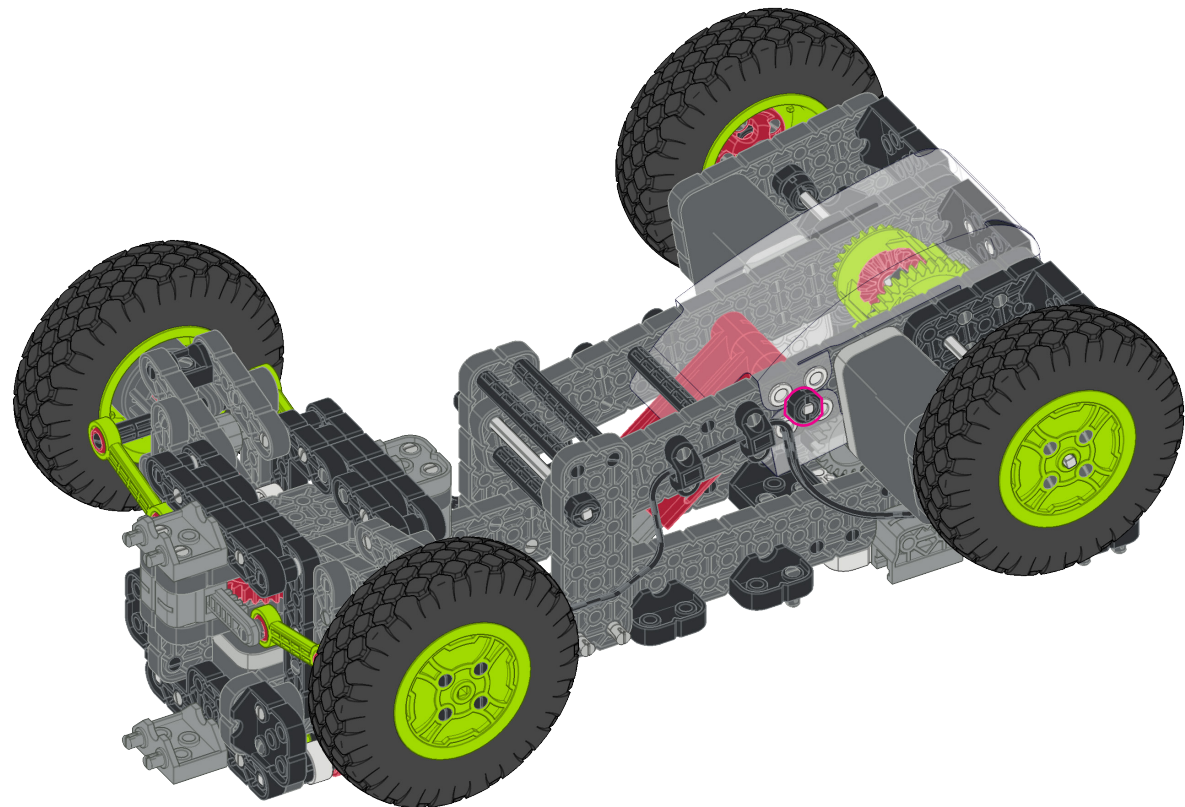
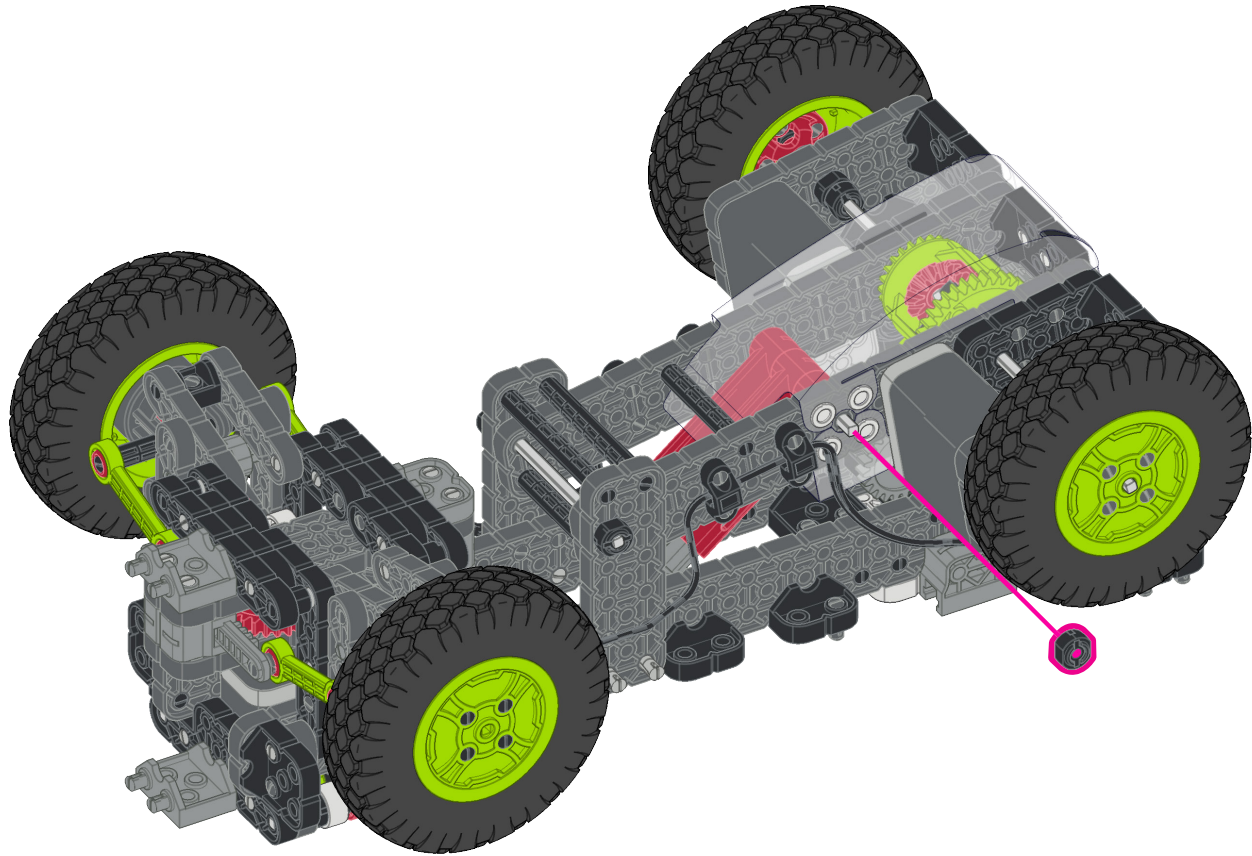

54

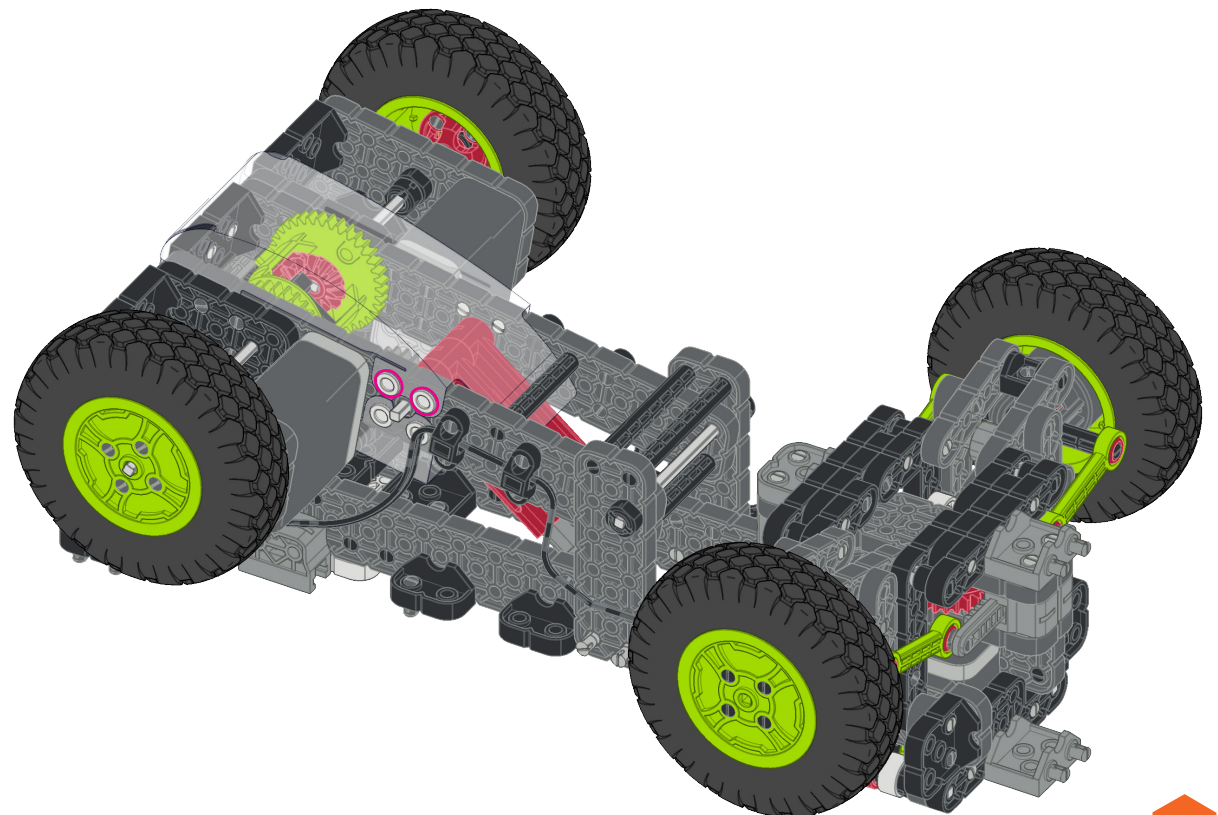
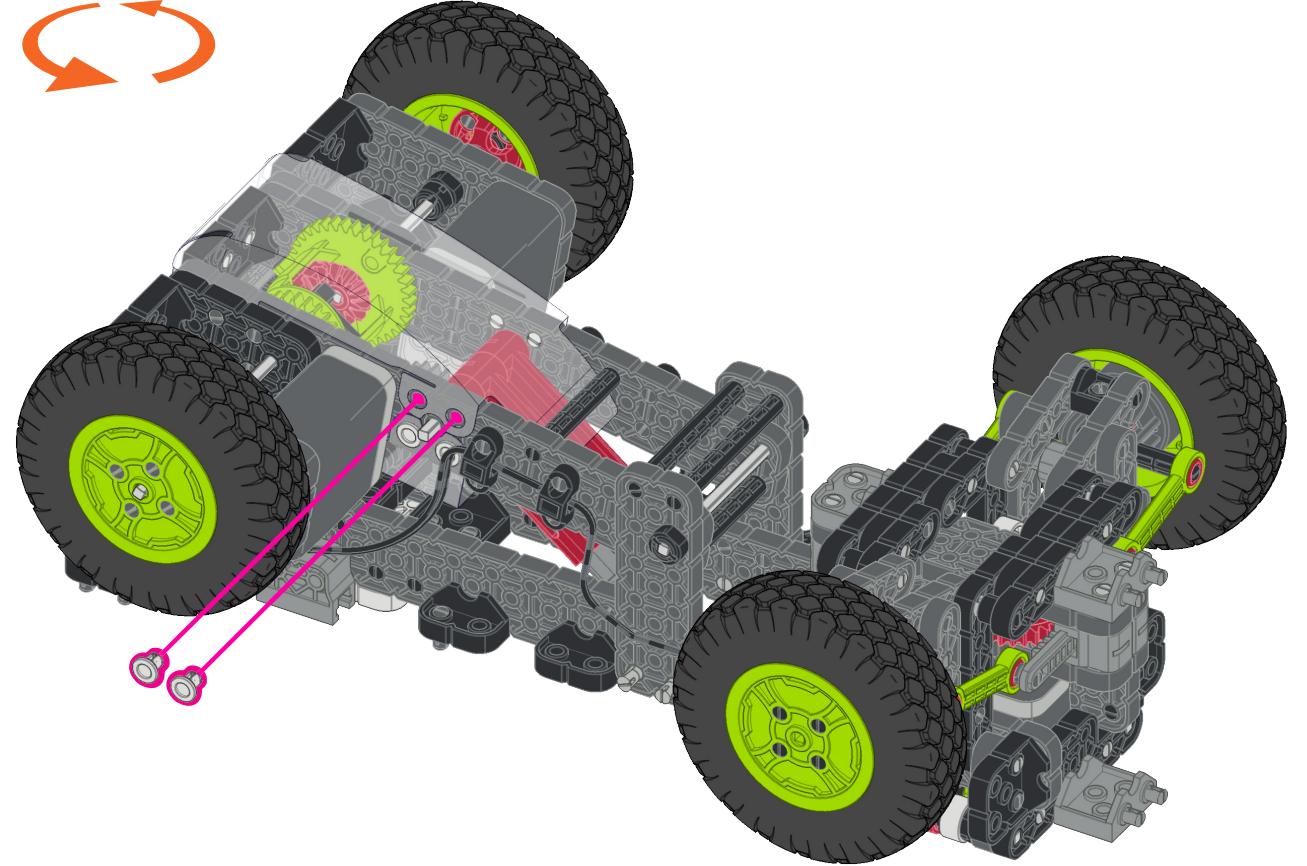

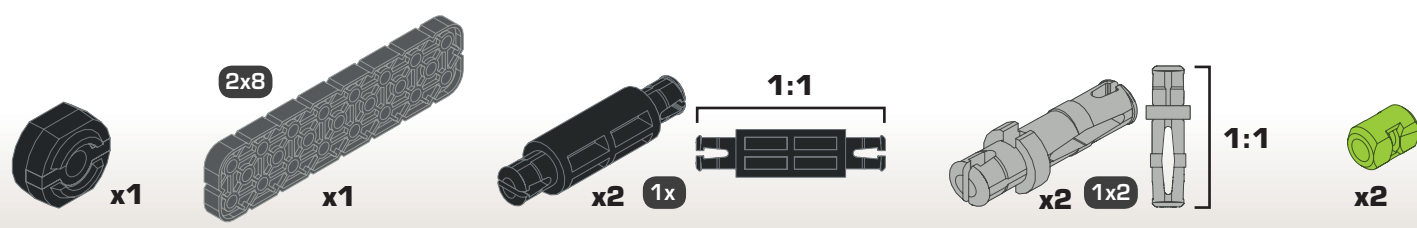

55

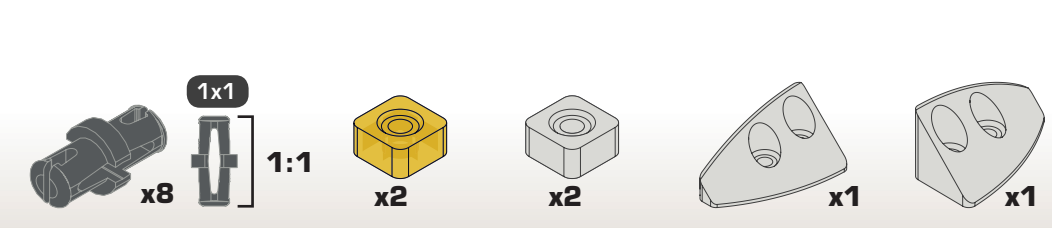
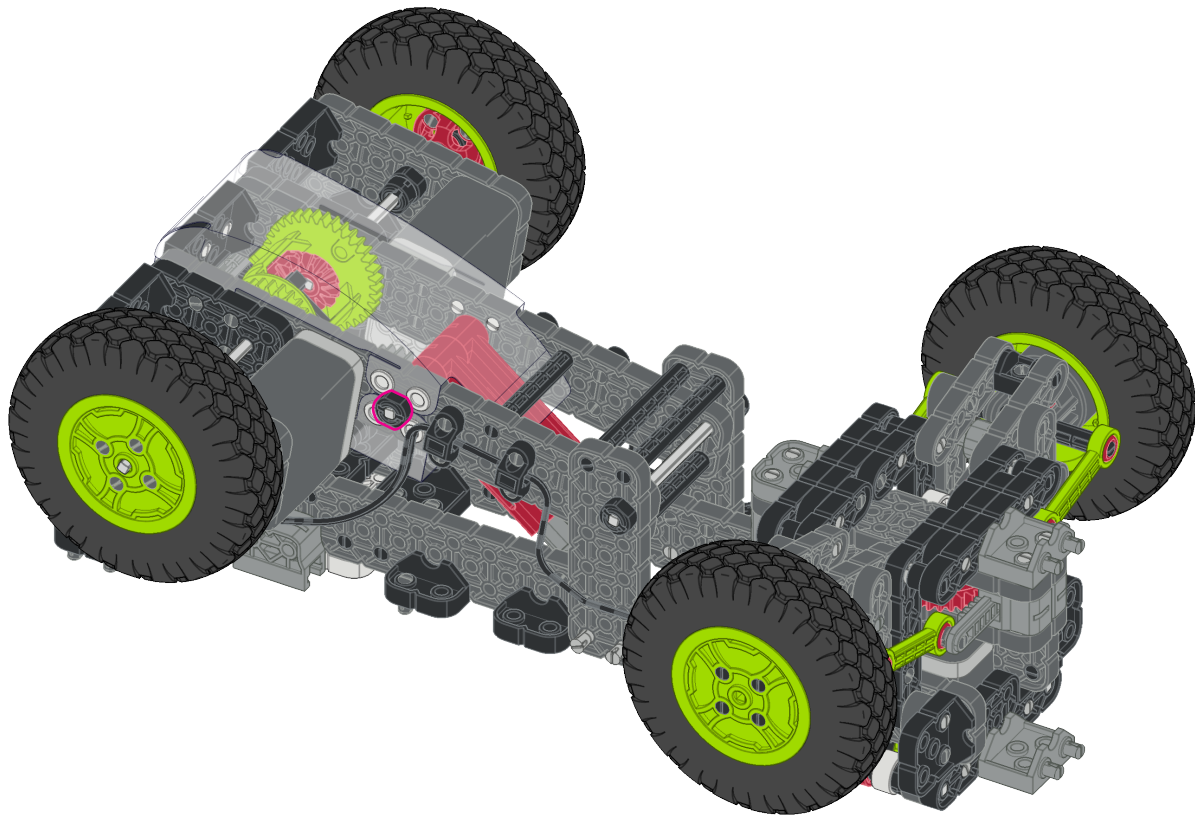
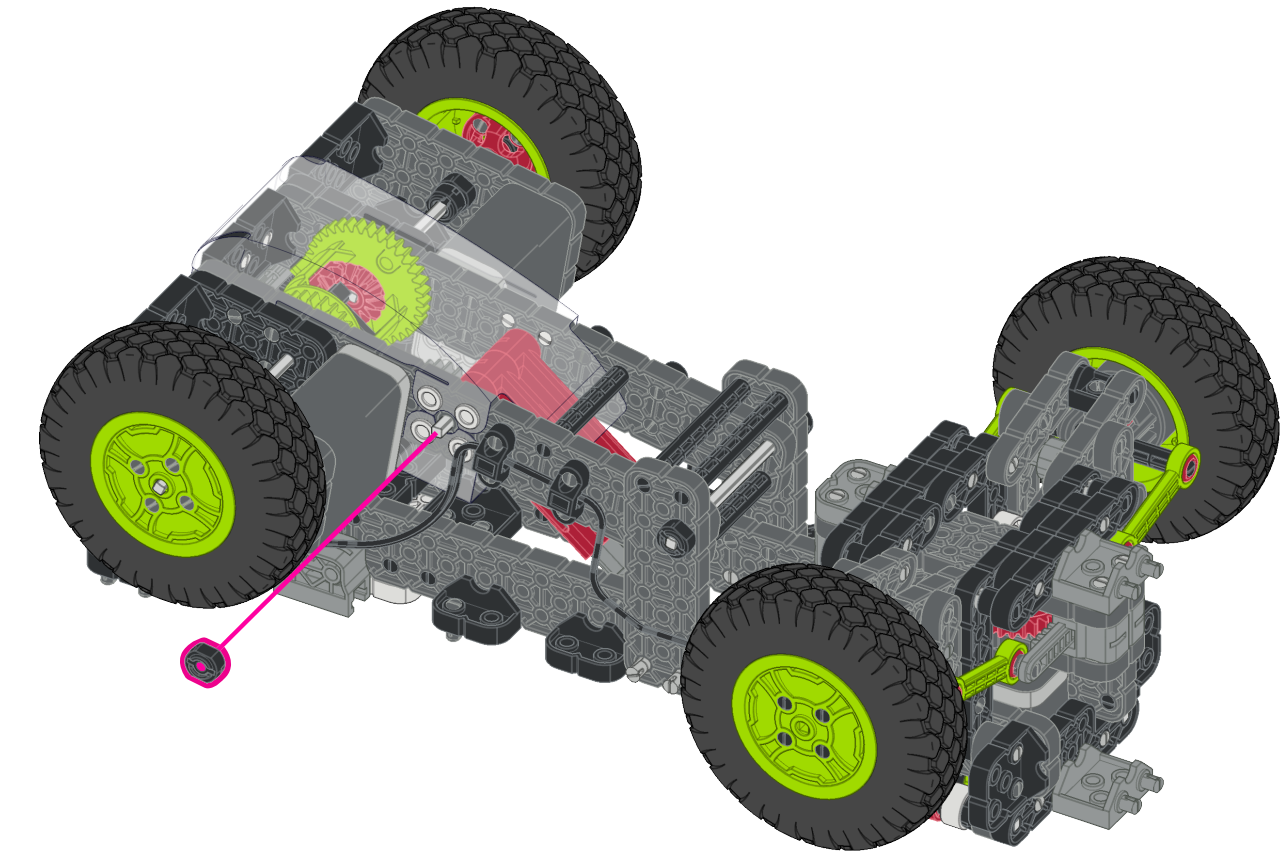

56

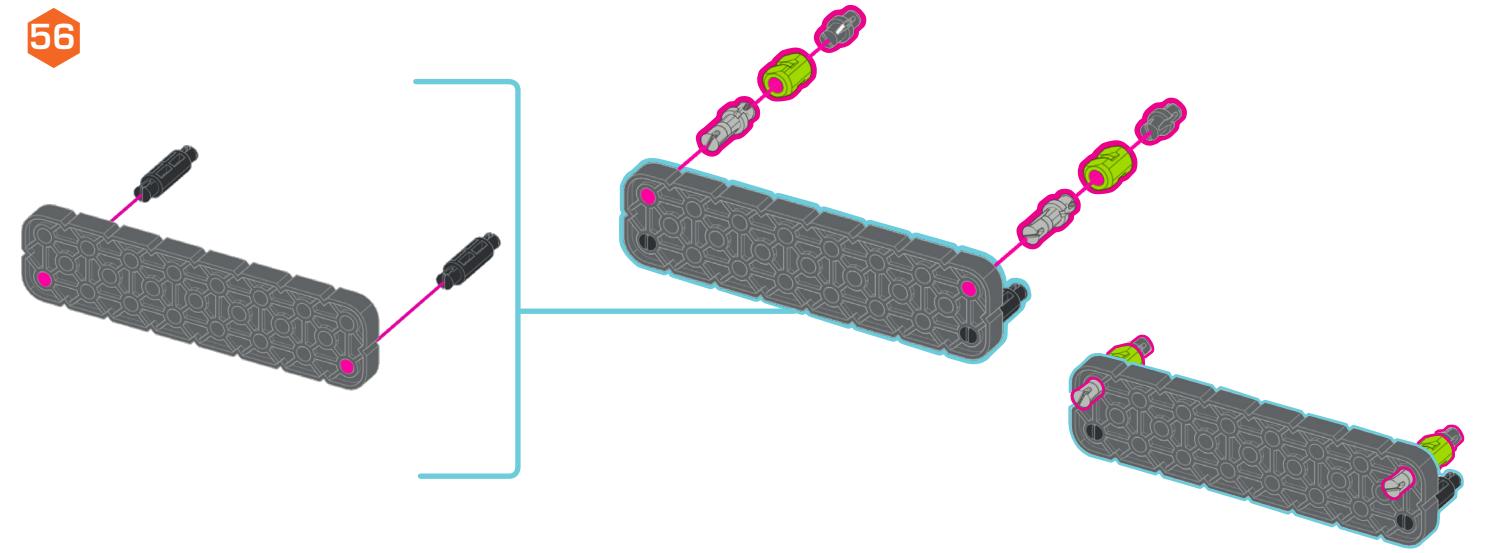

57

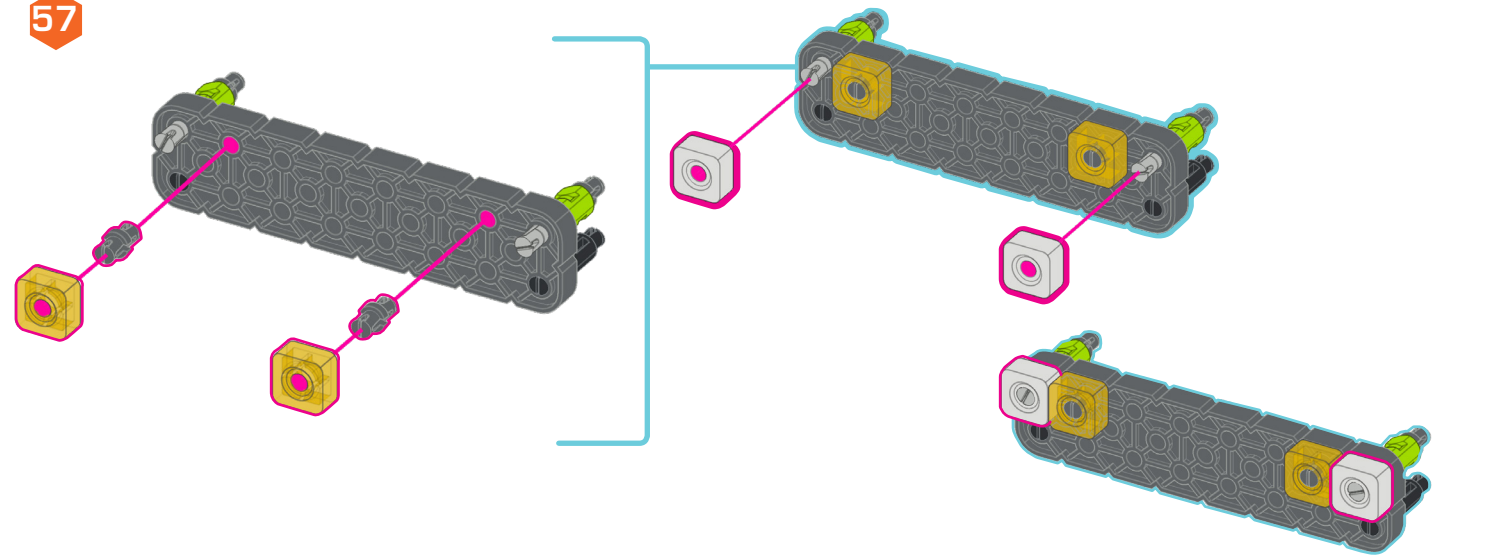

58

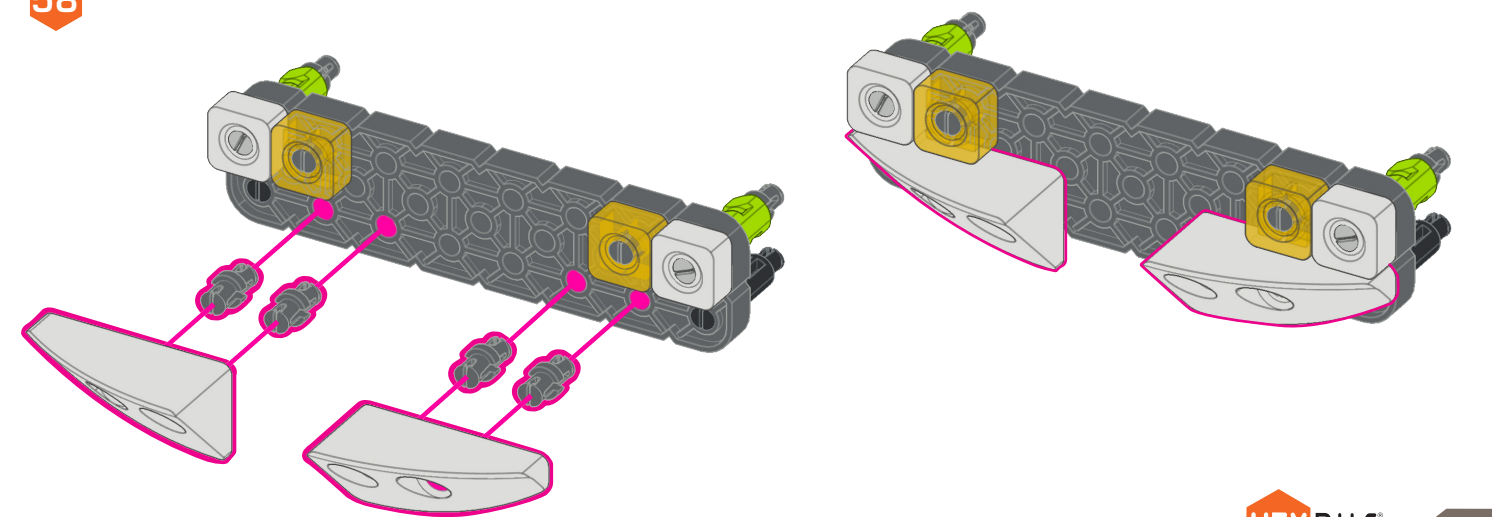

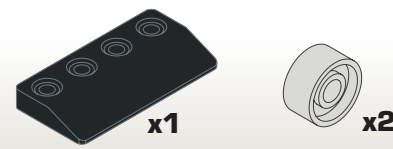
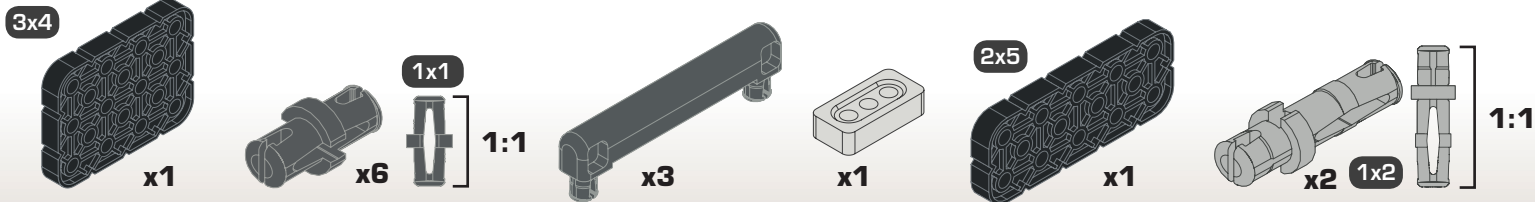

59

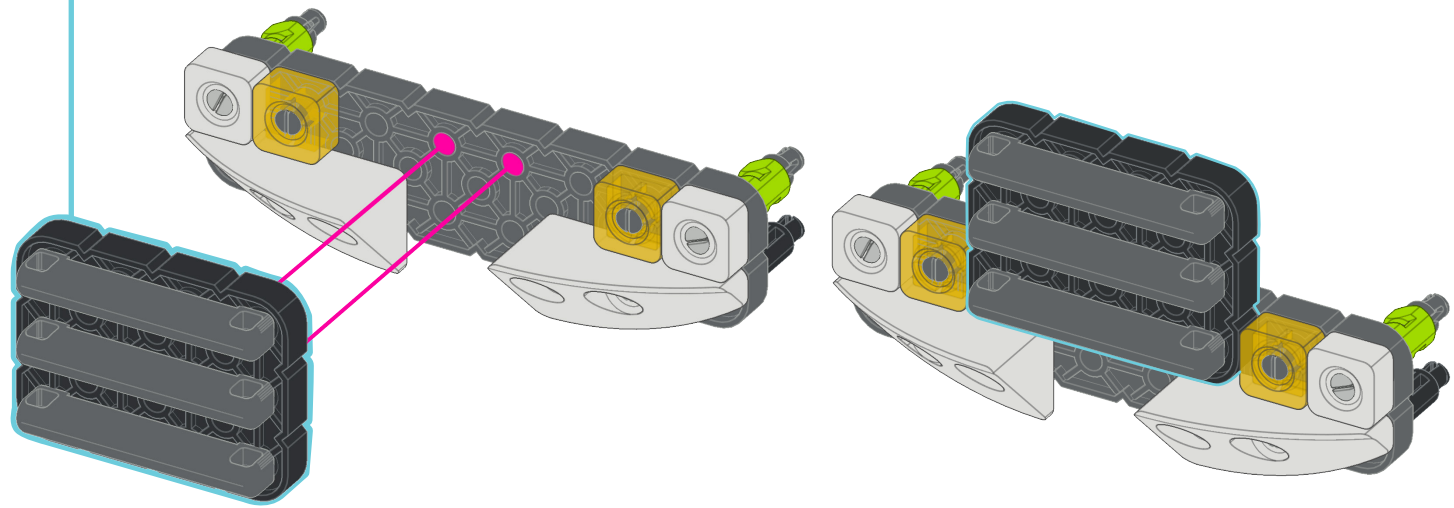
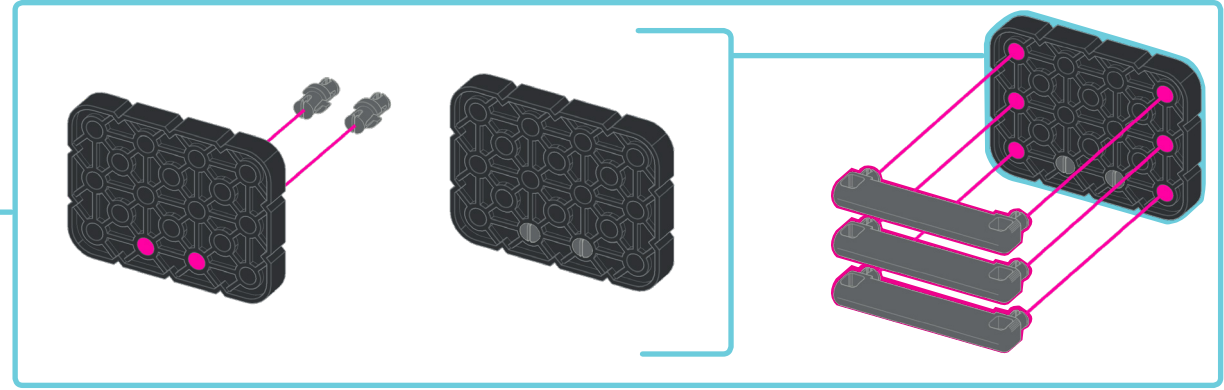

61

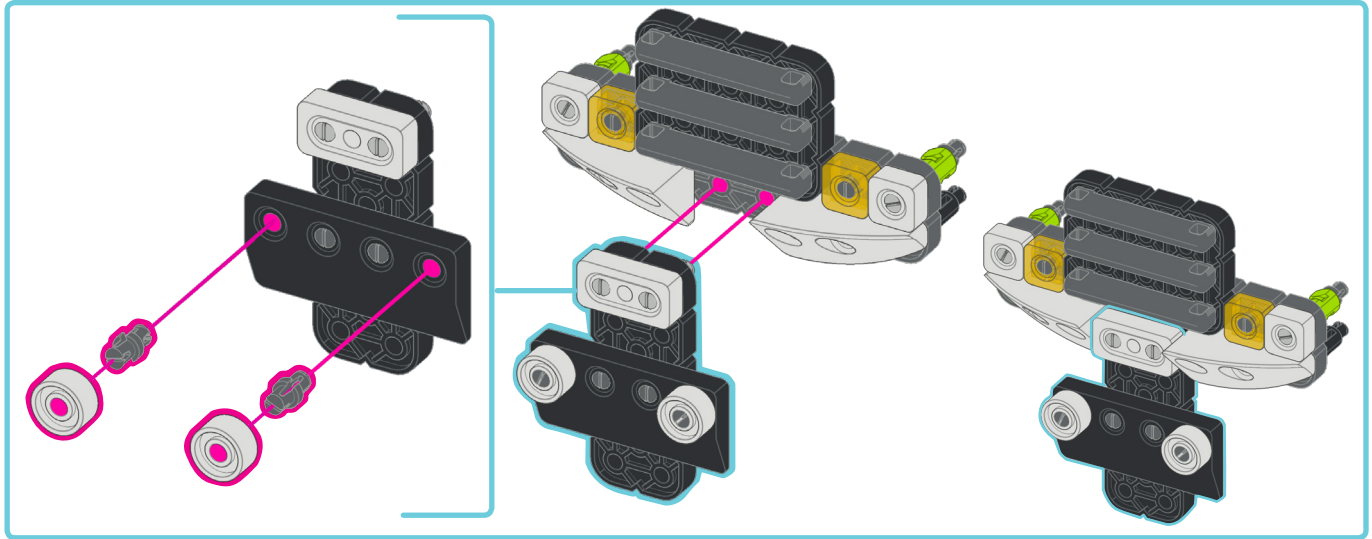

60

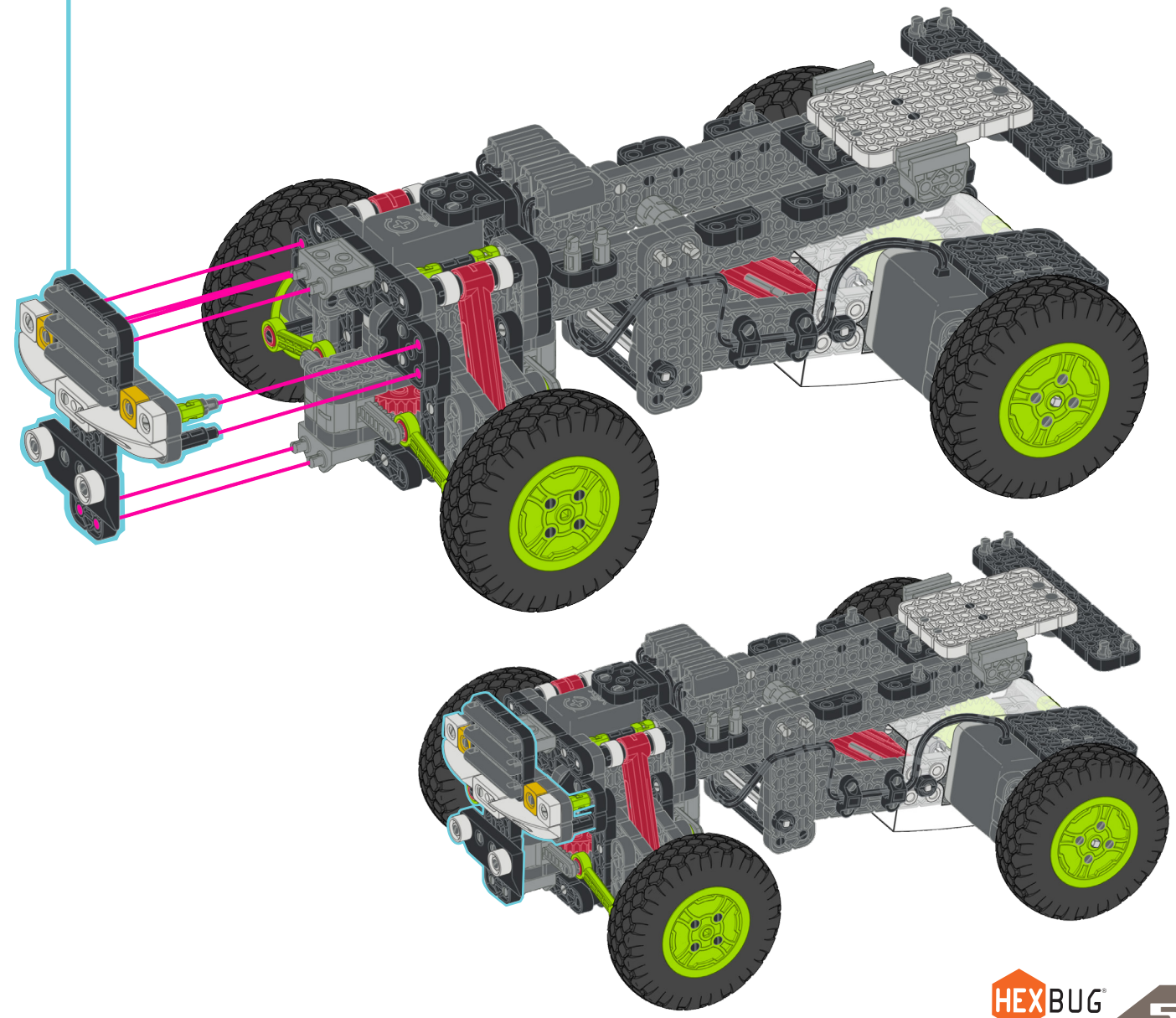
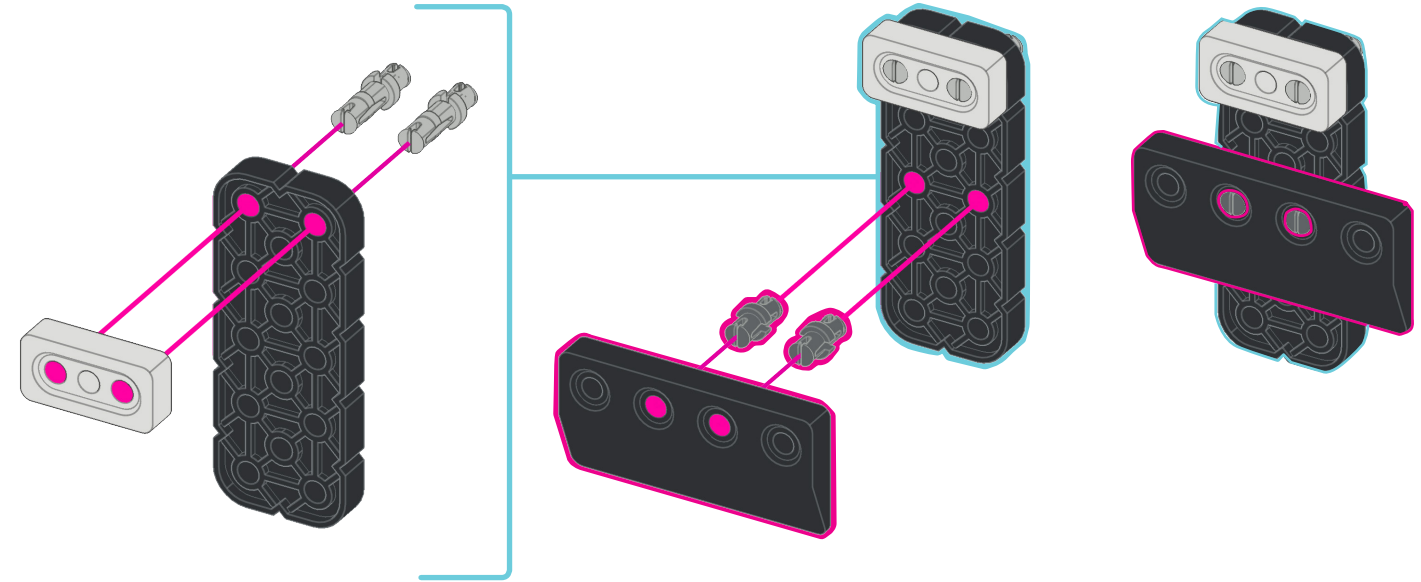

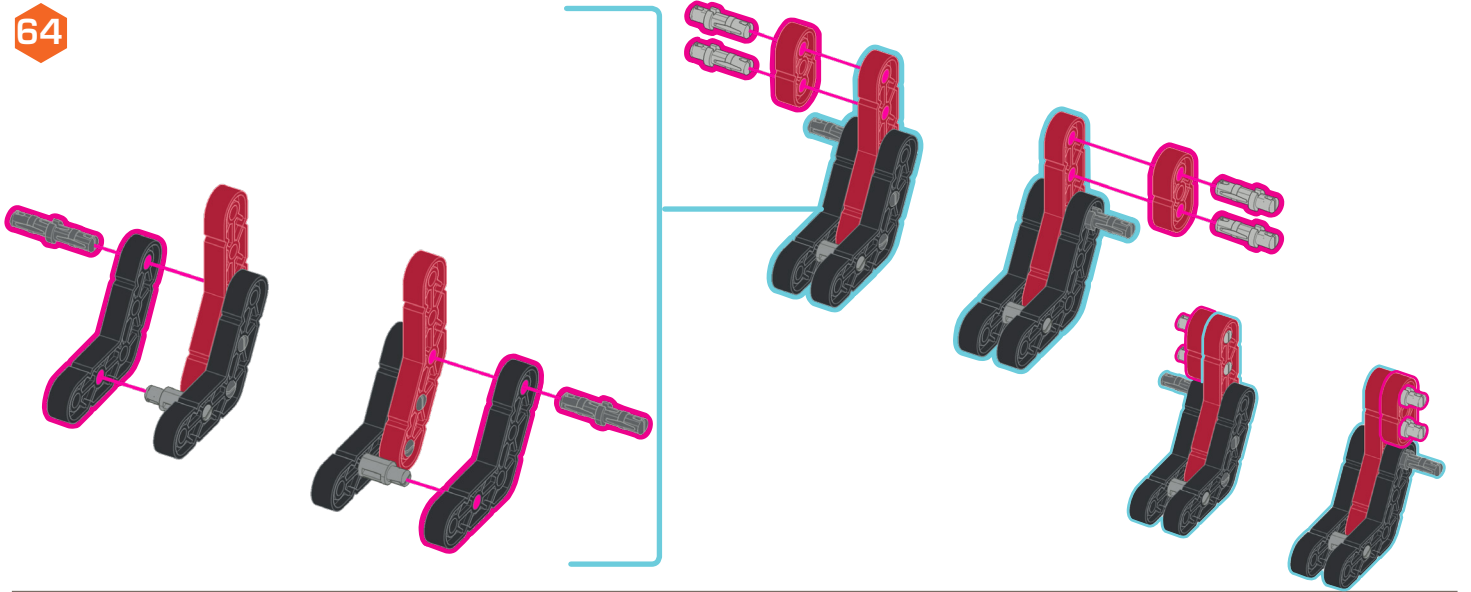
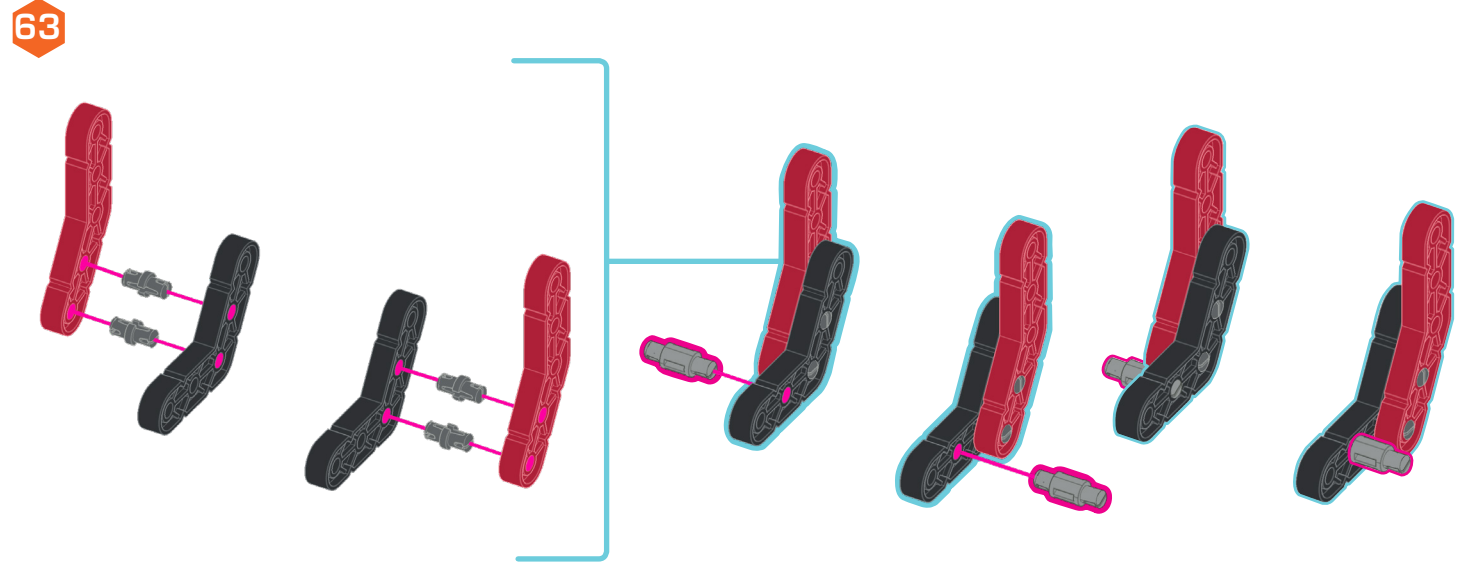
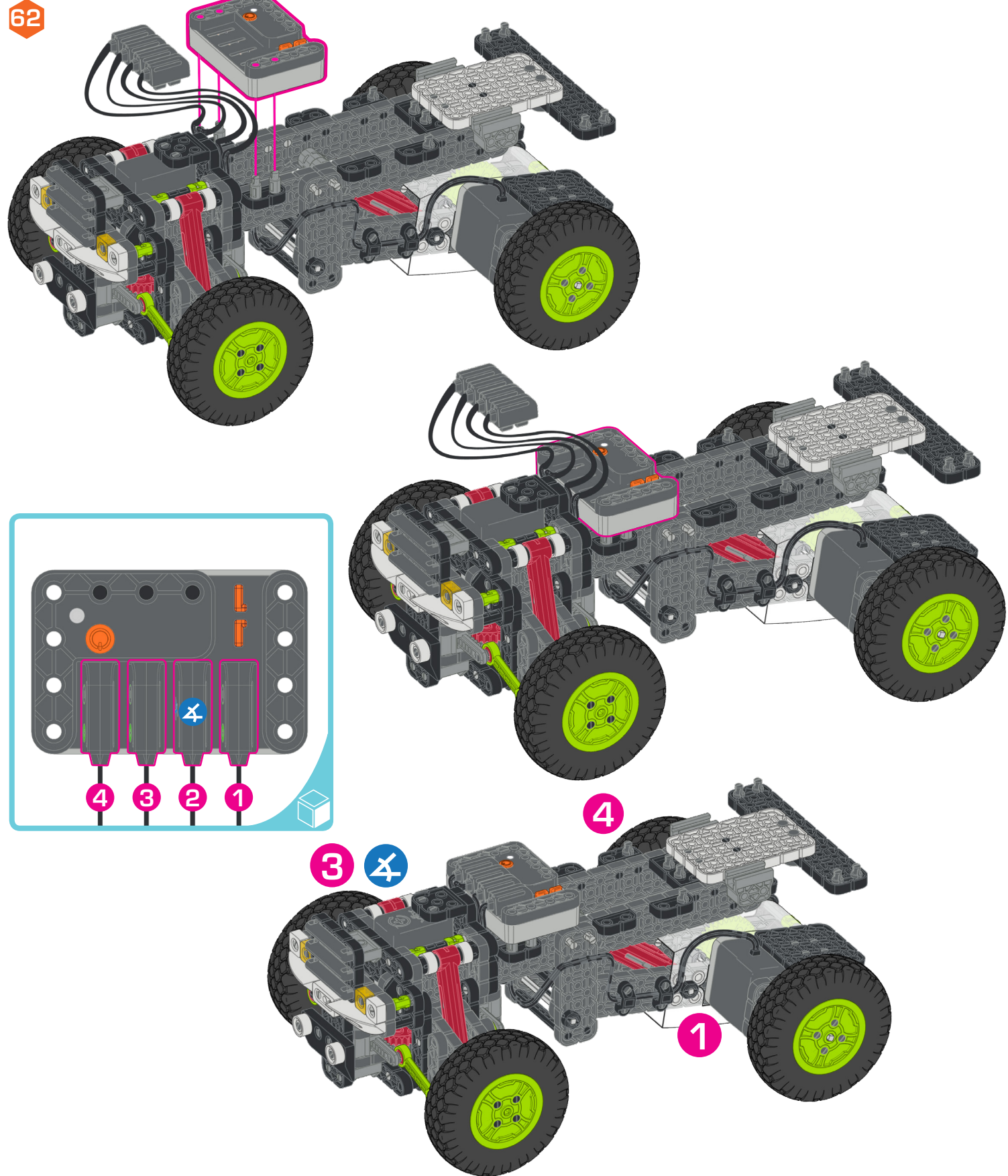
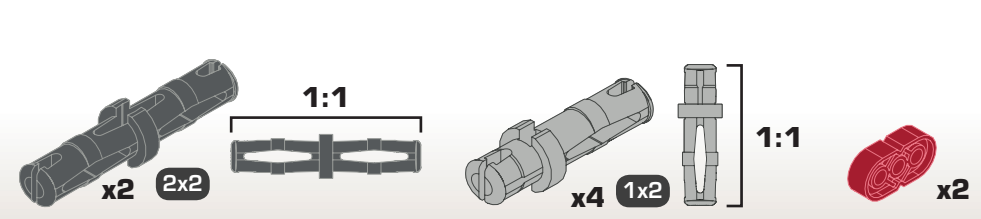
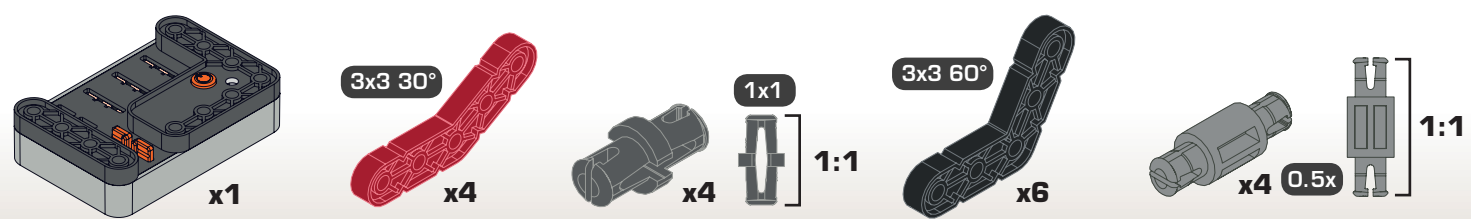

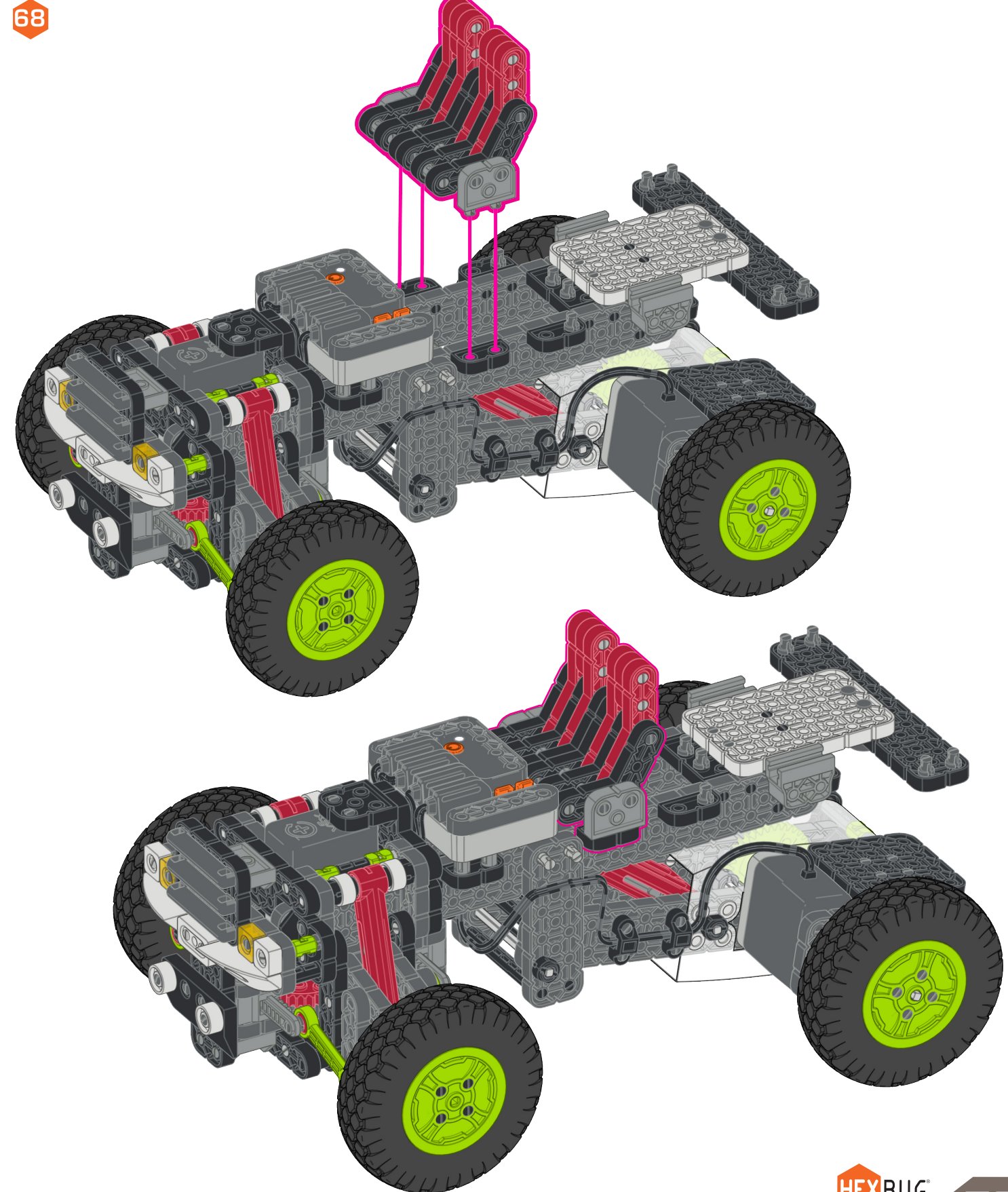
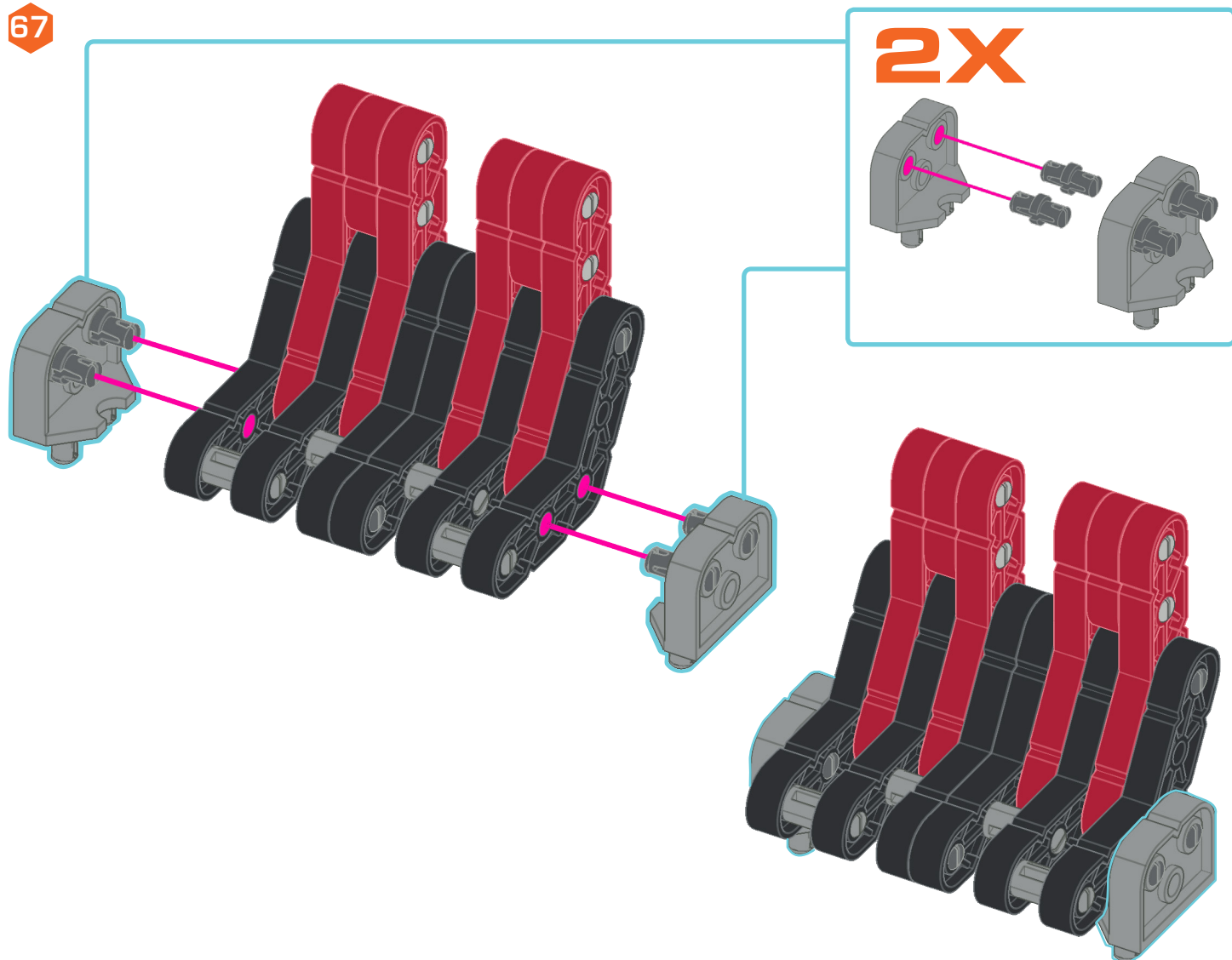
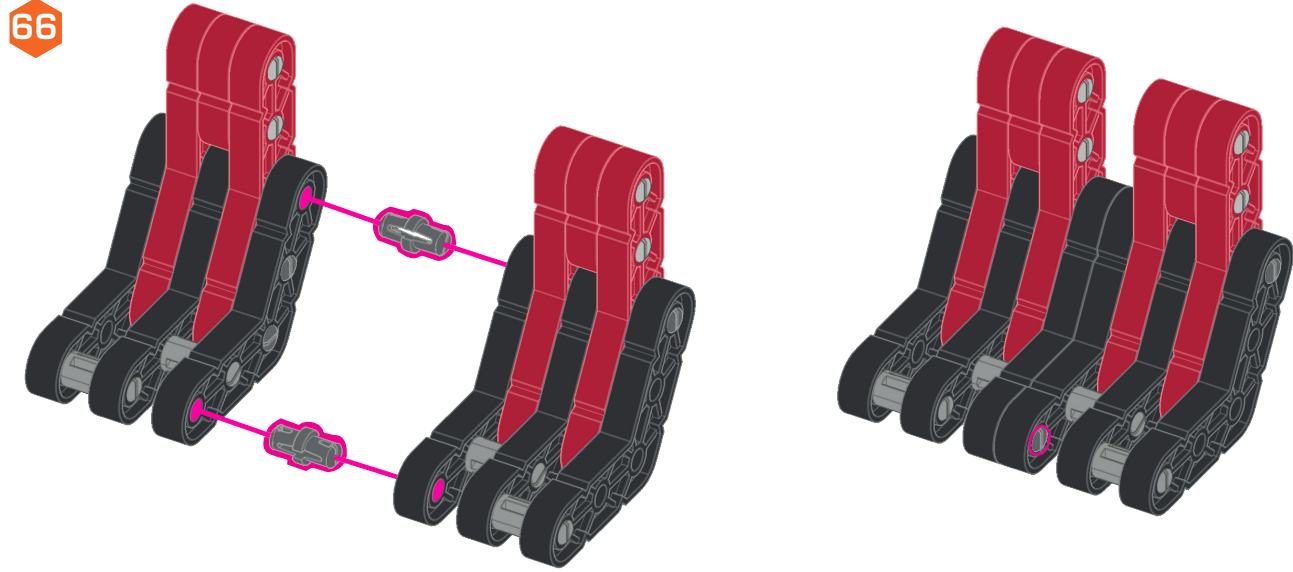

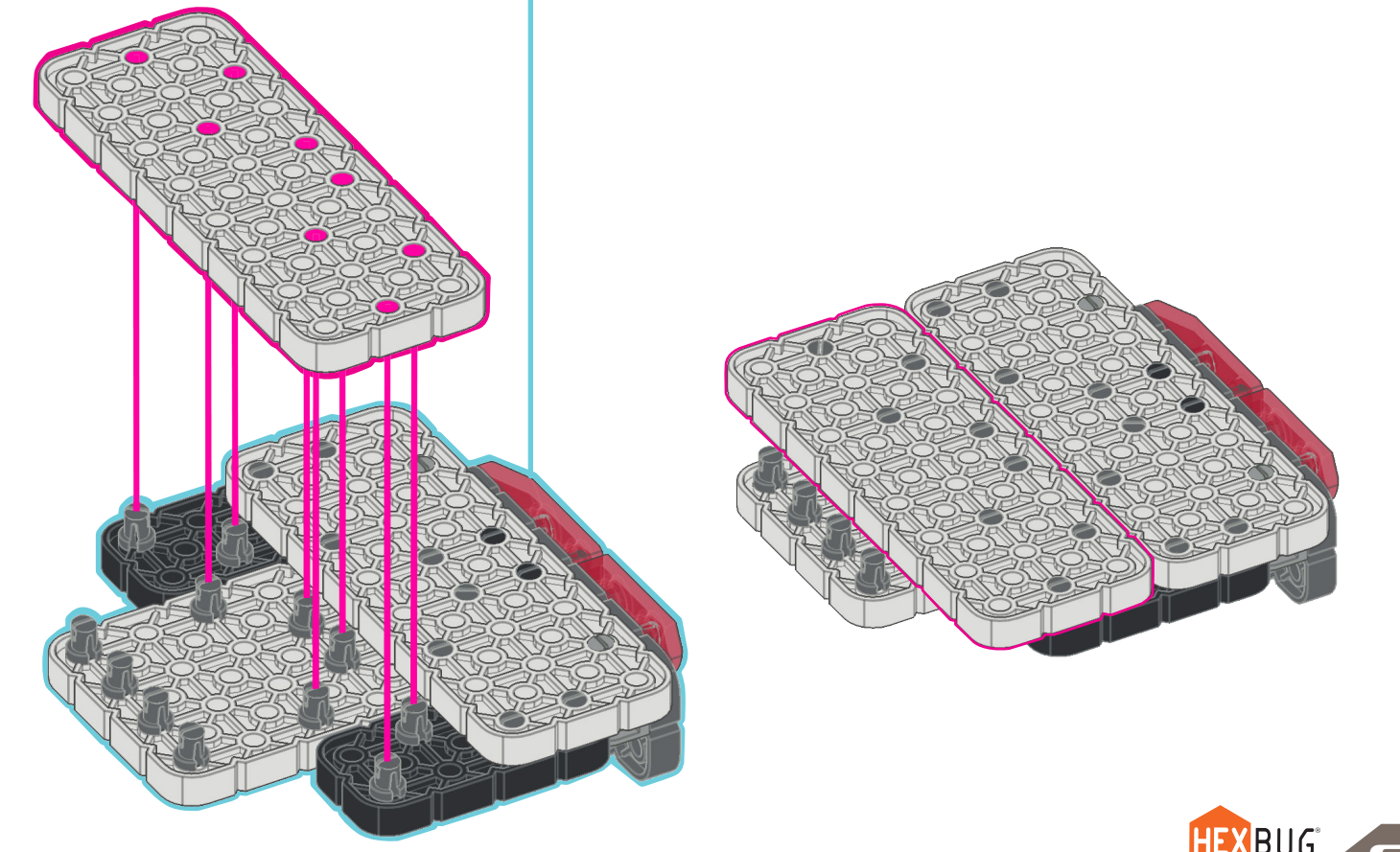
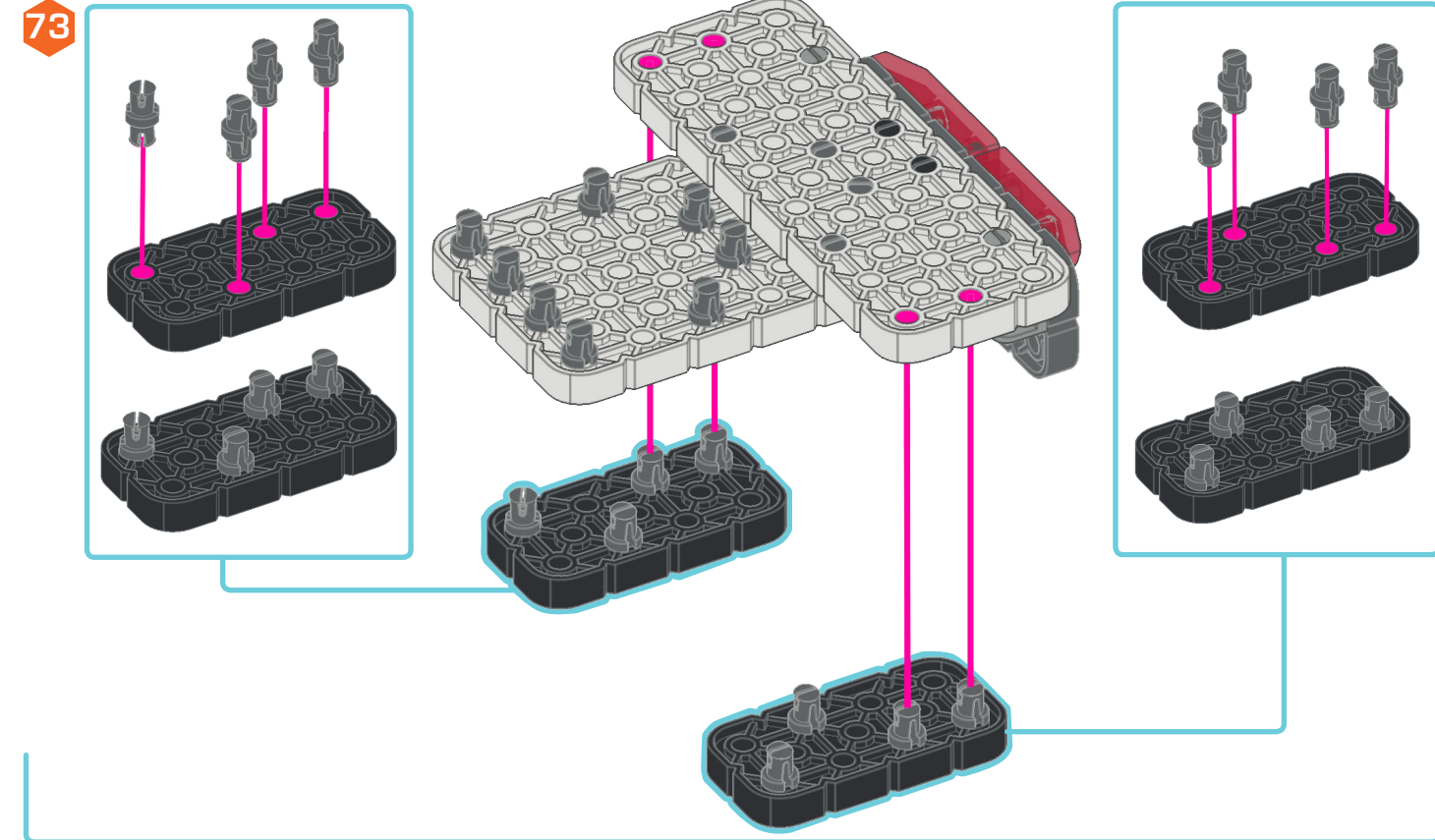
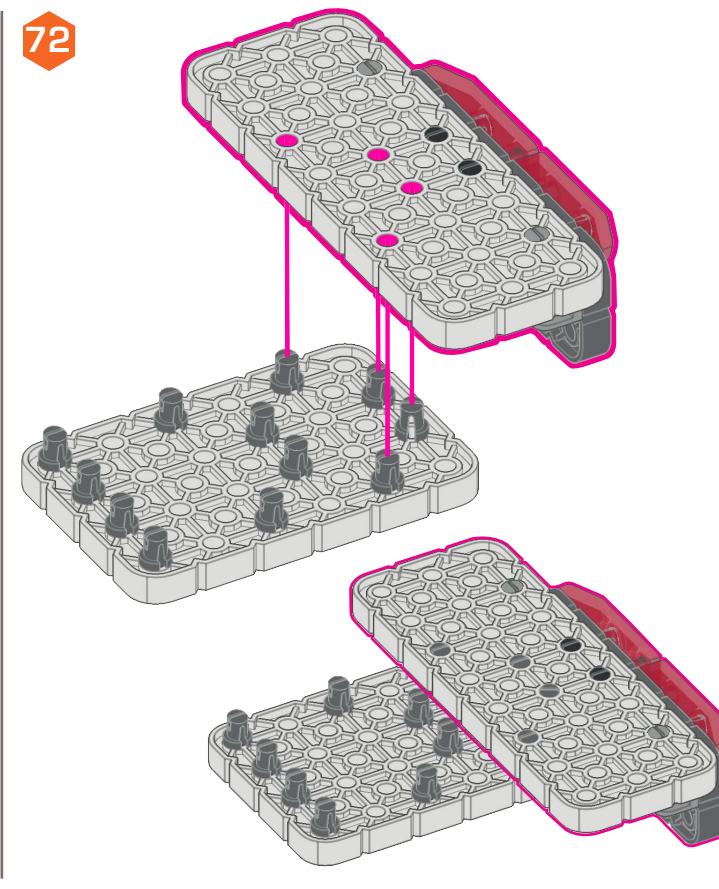
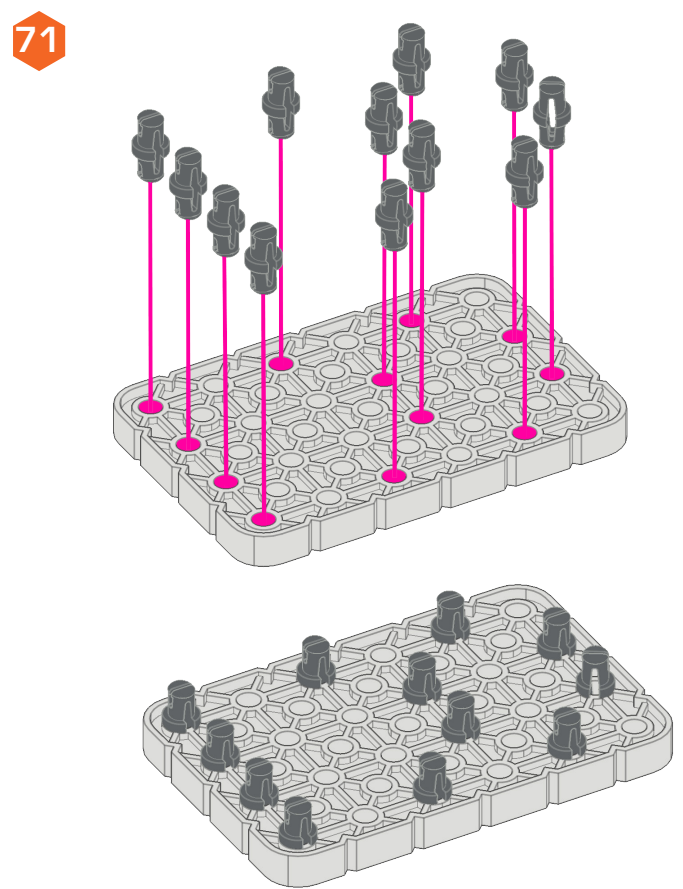
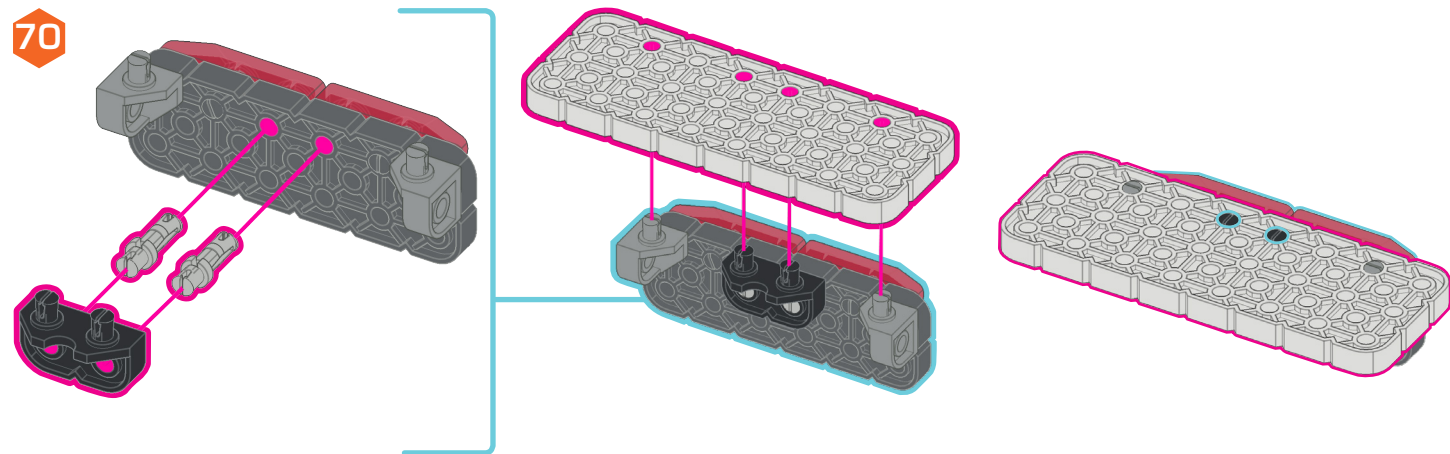
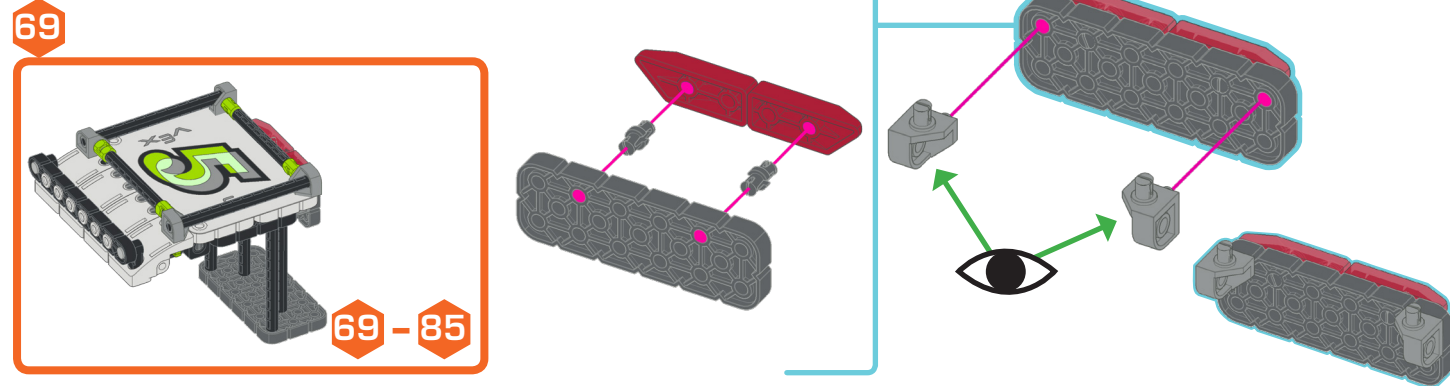
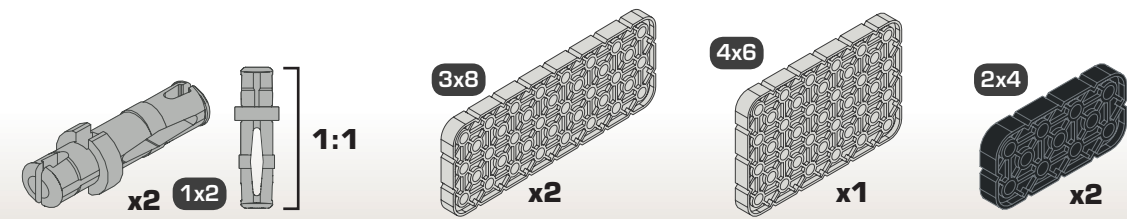
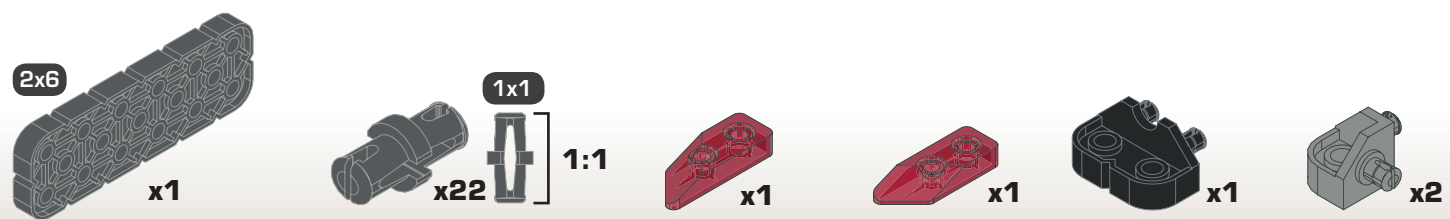

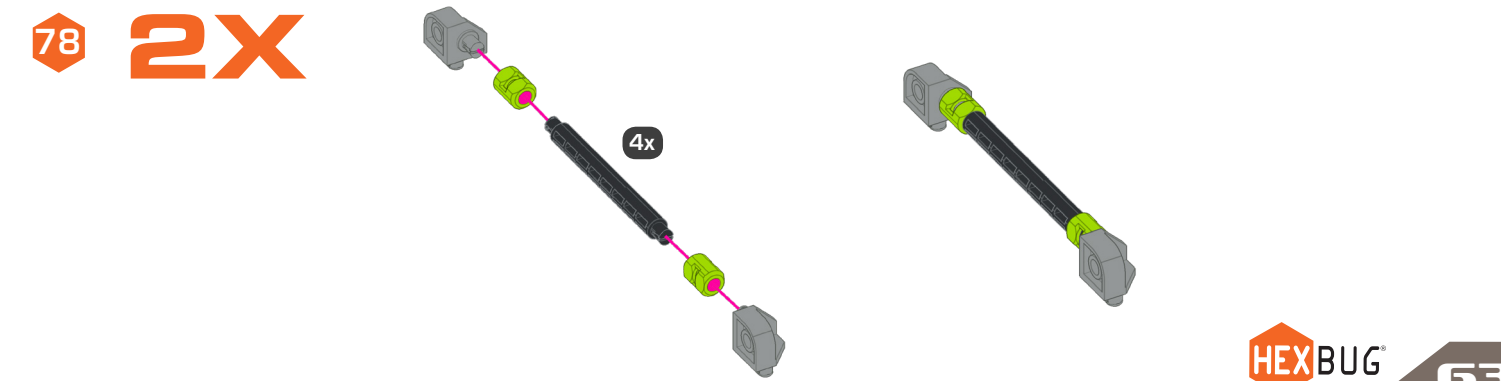
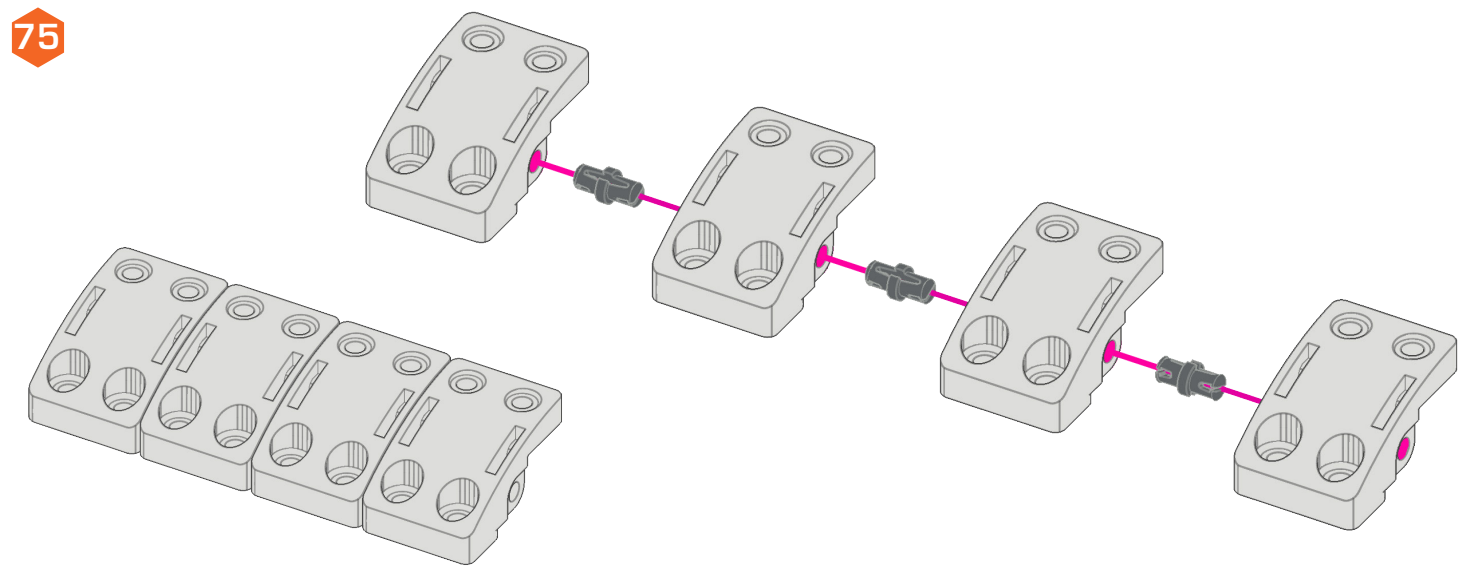
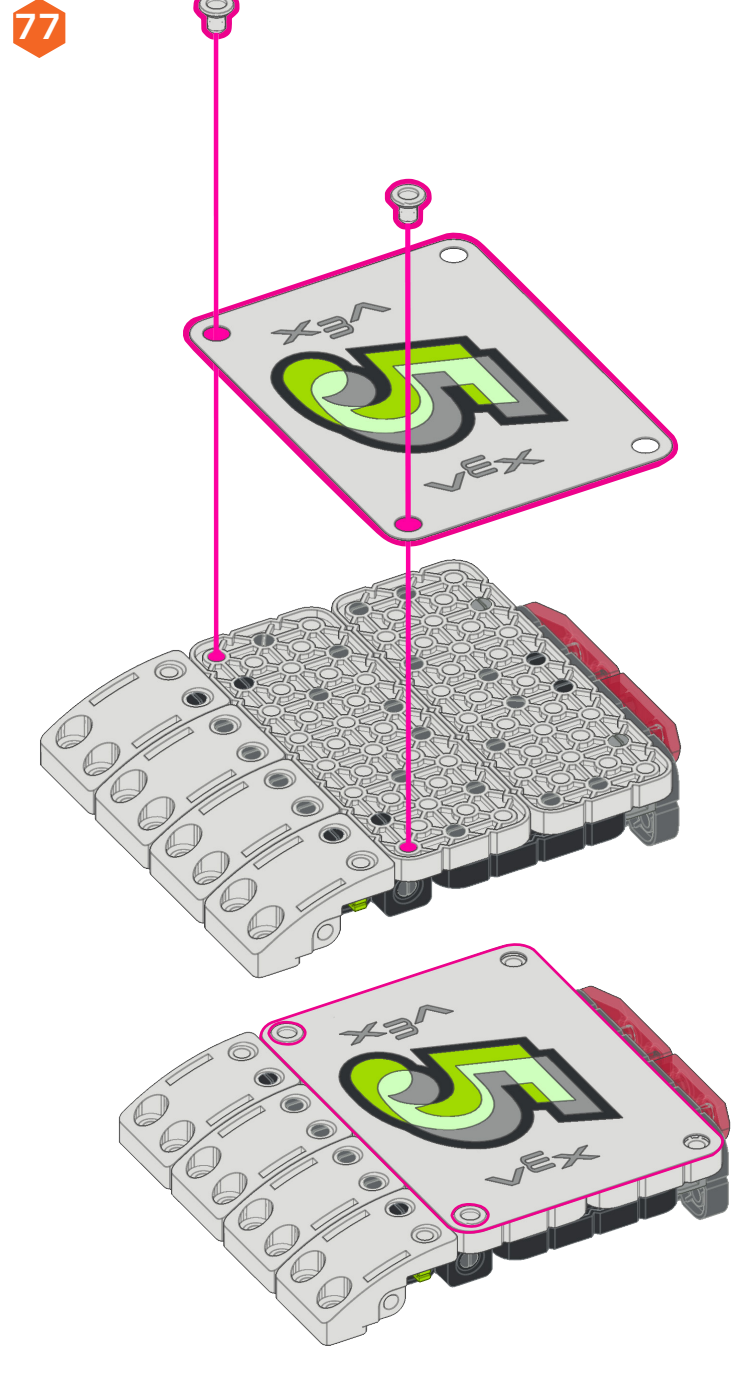
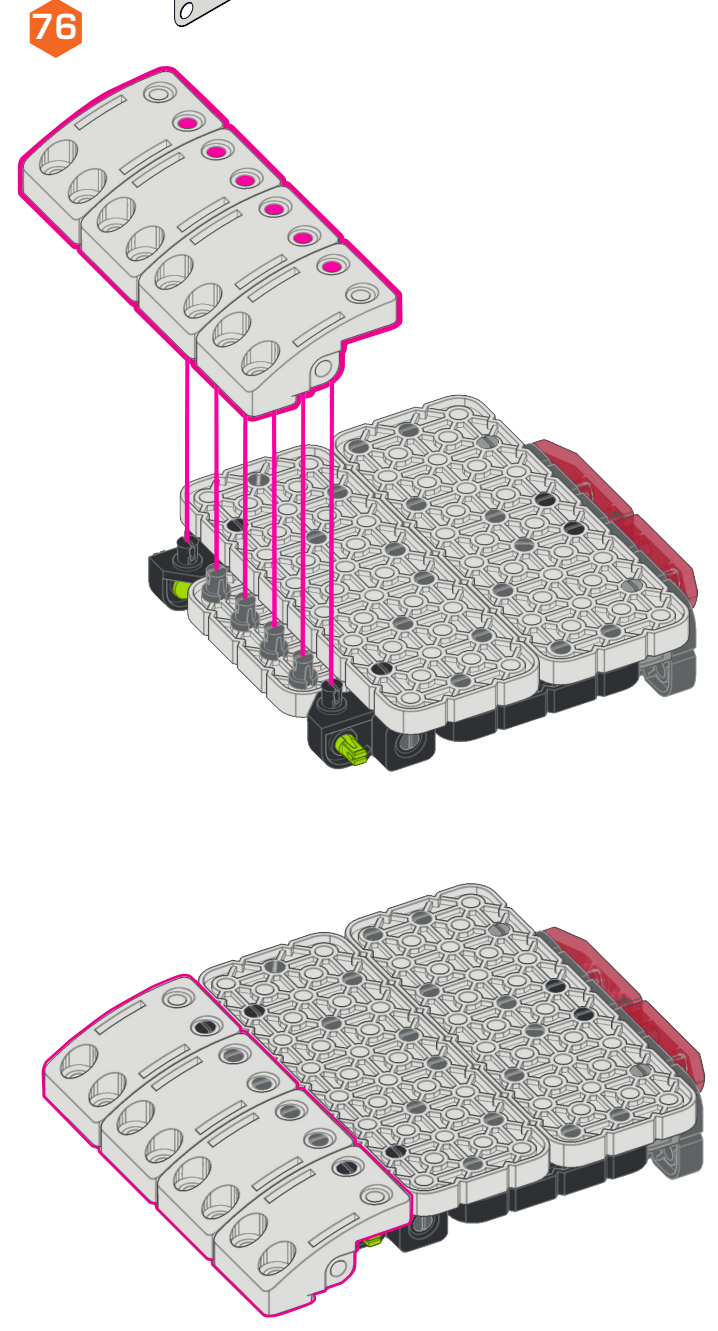
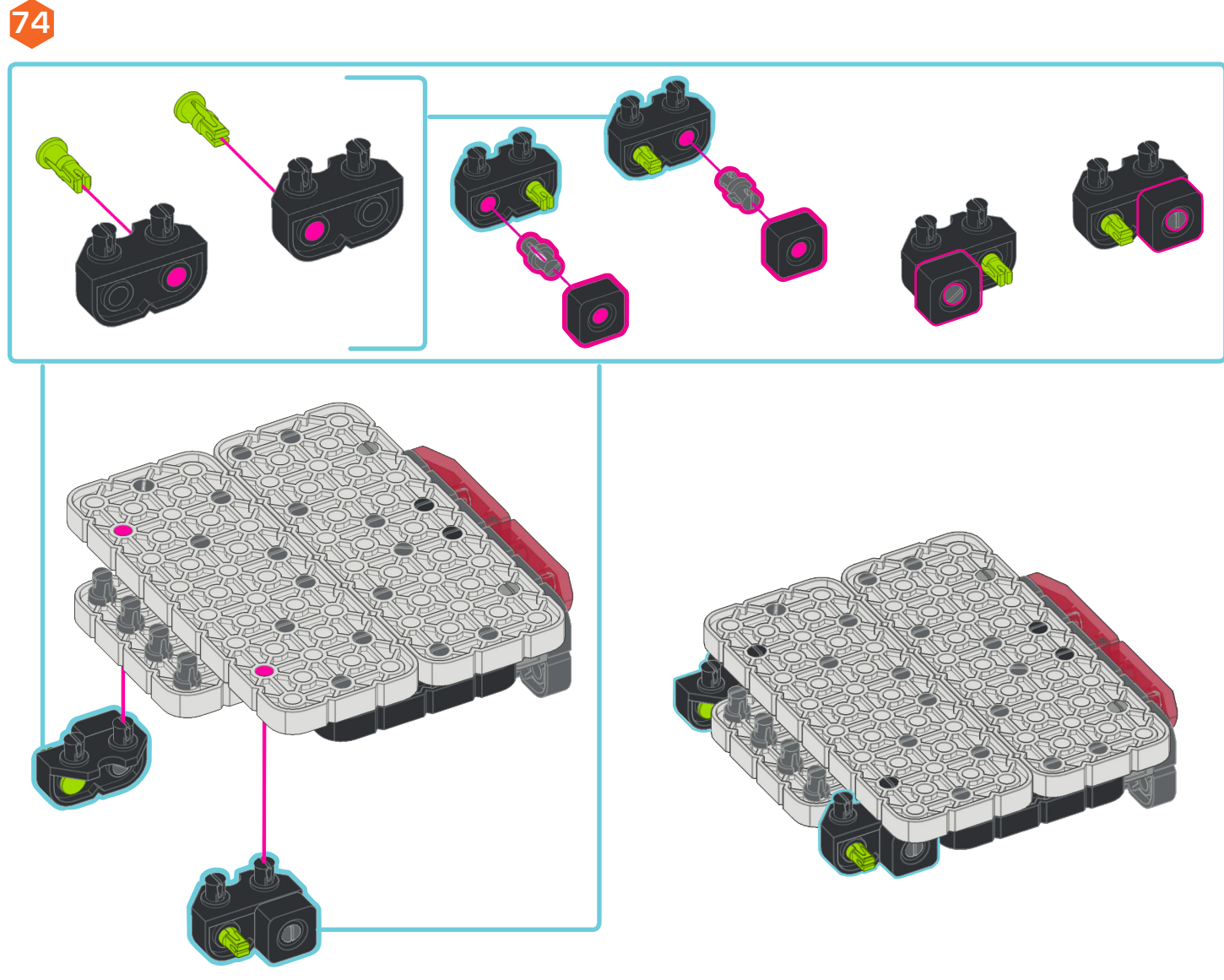
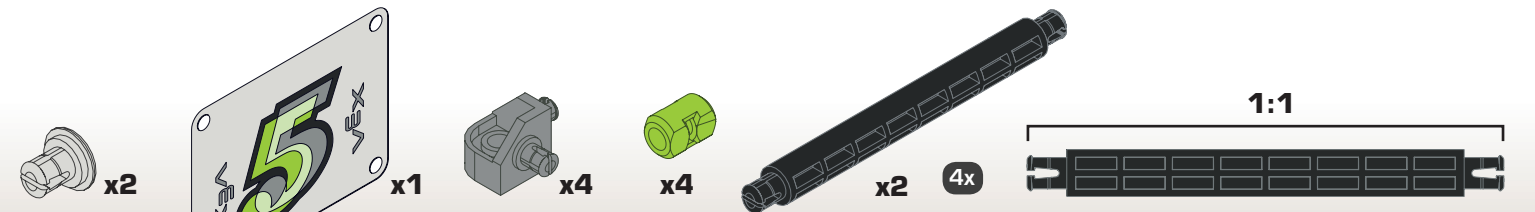
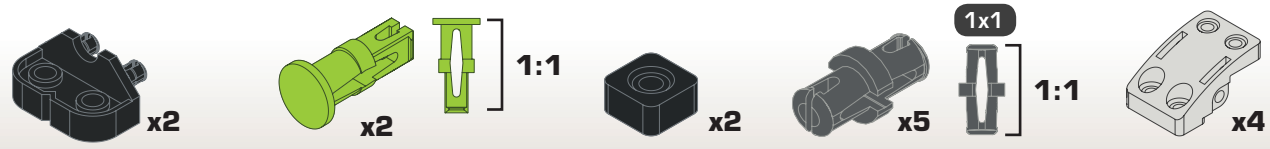

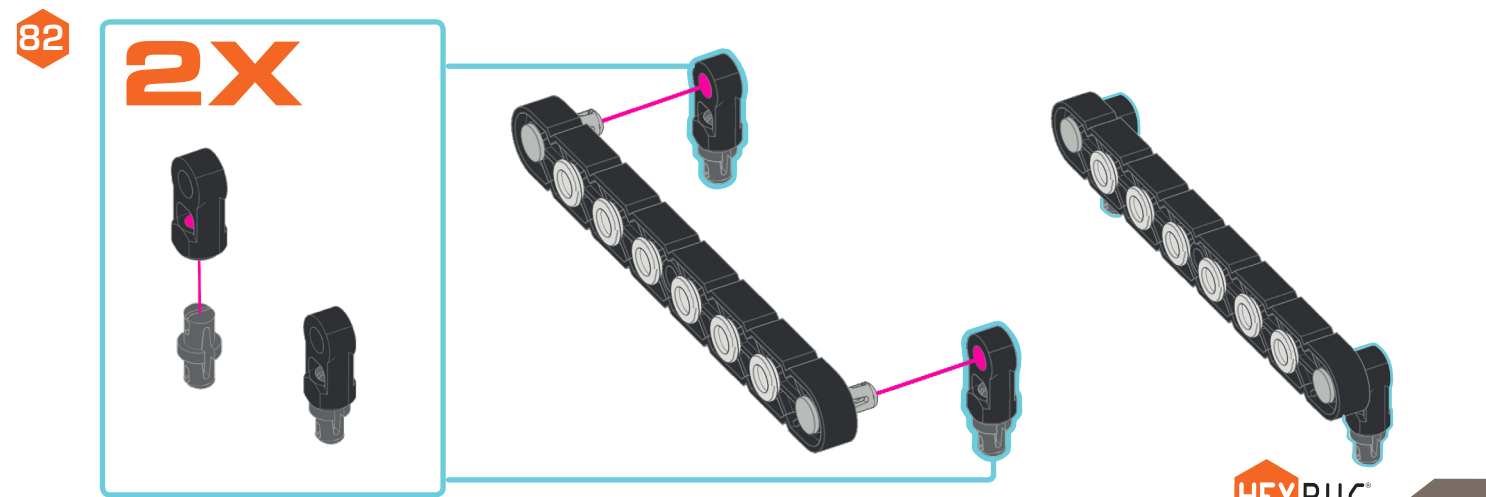
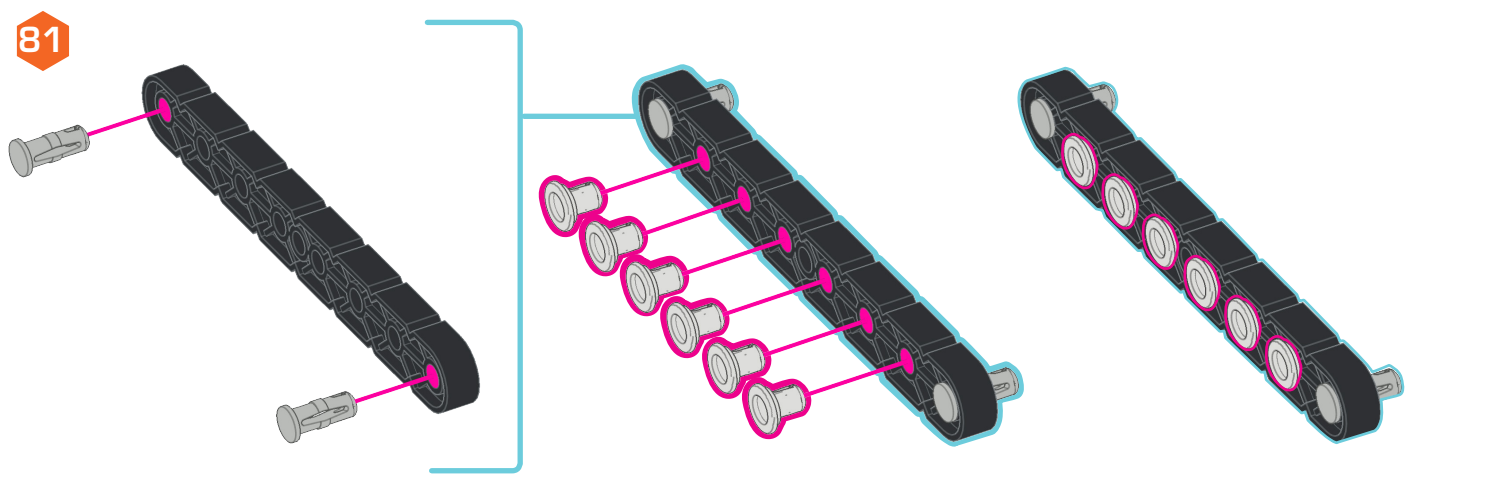
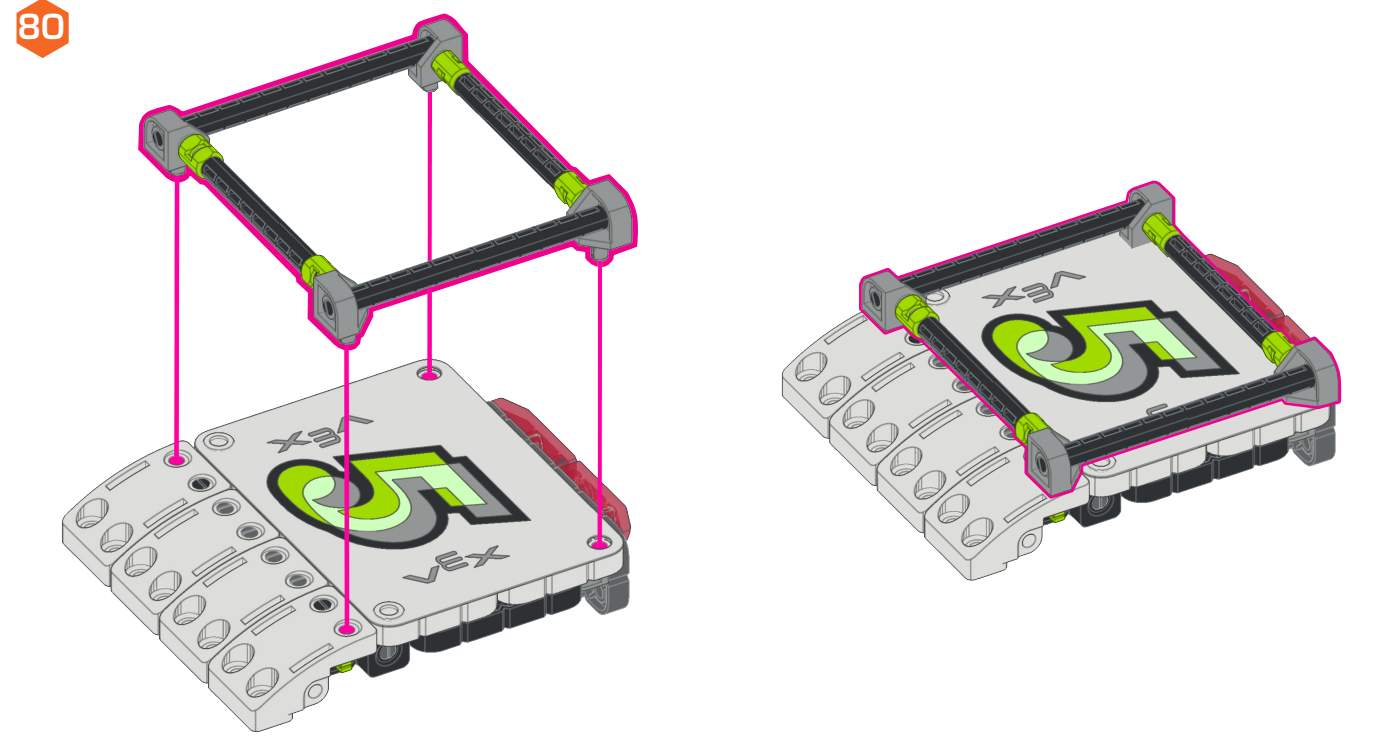
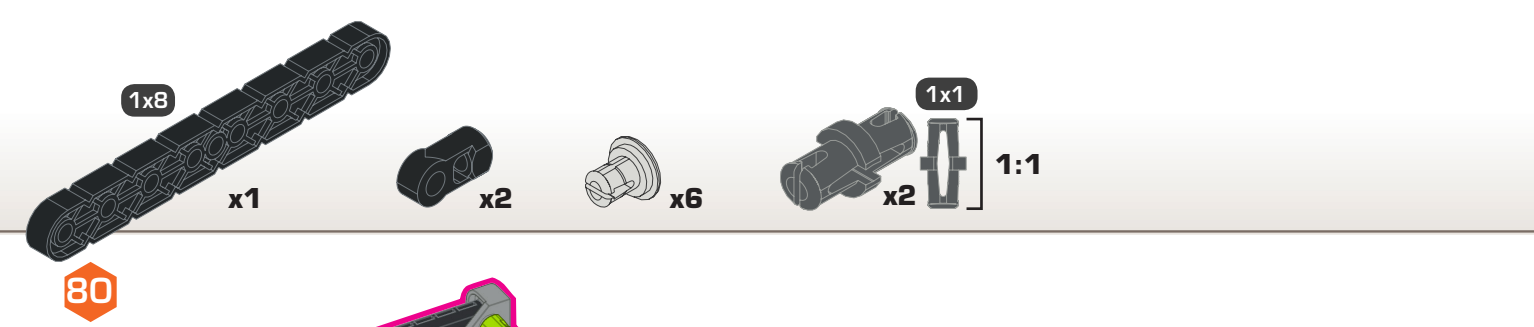
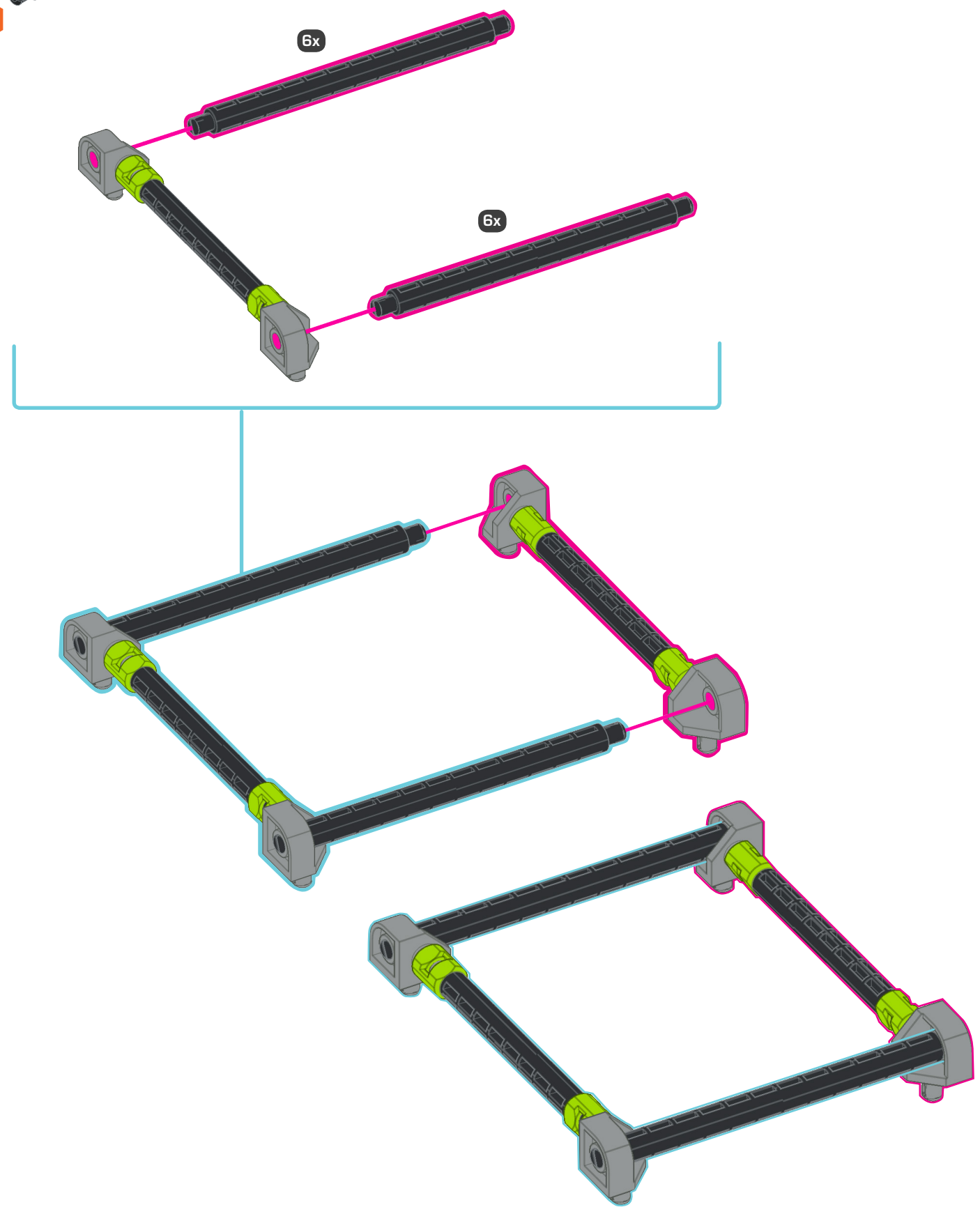
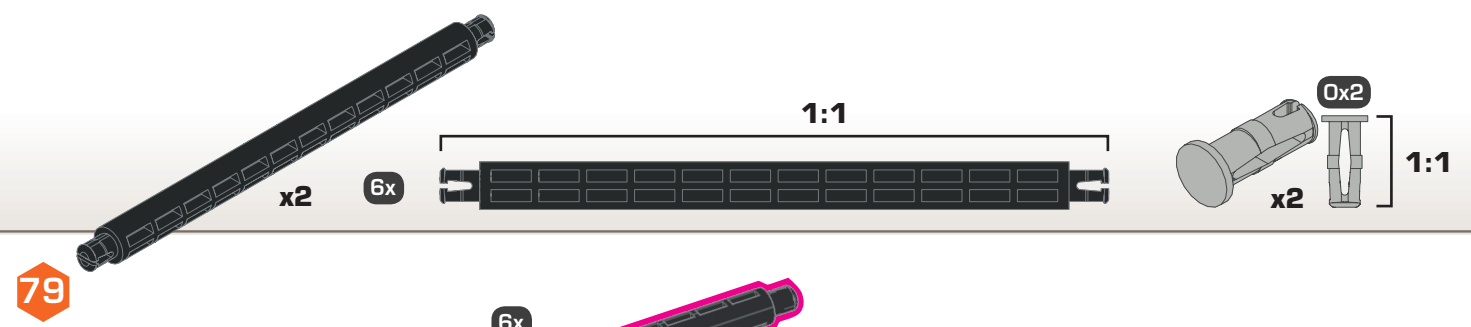

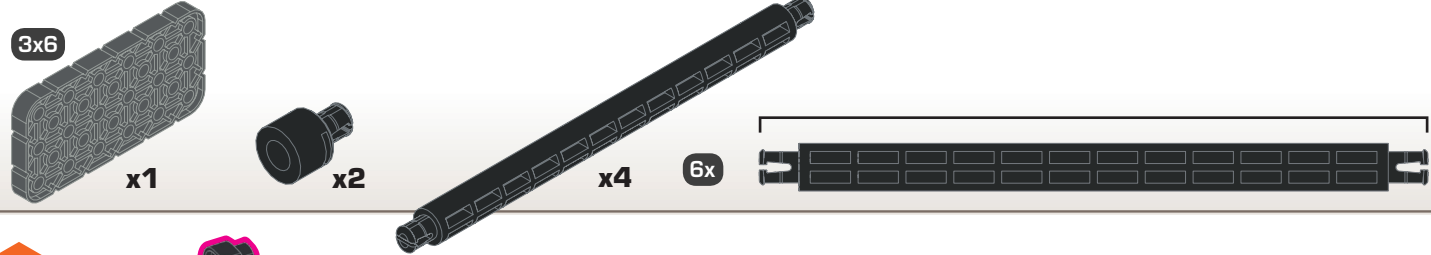

83

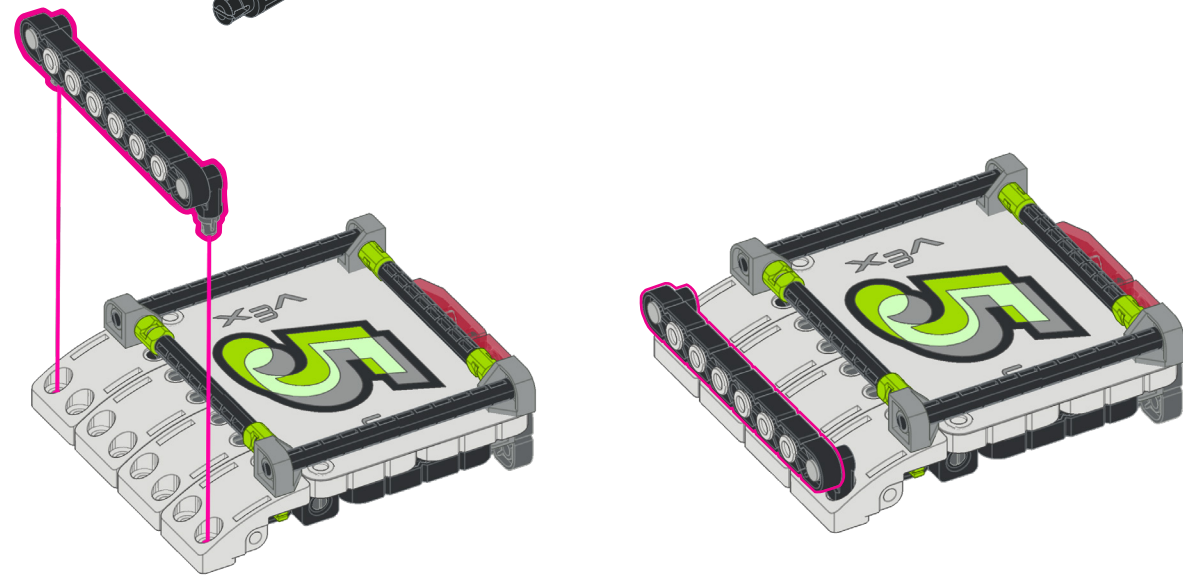

84

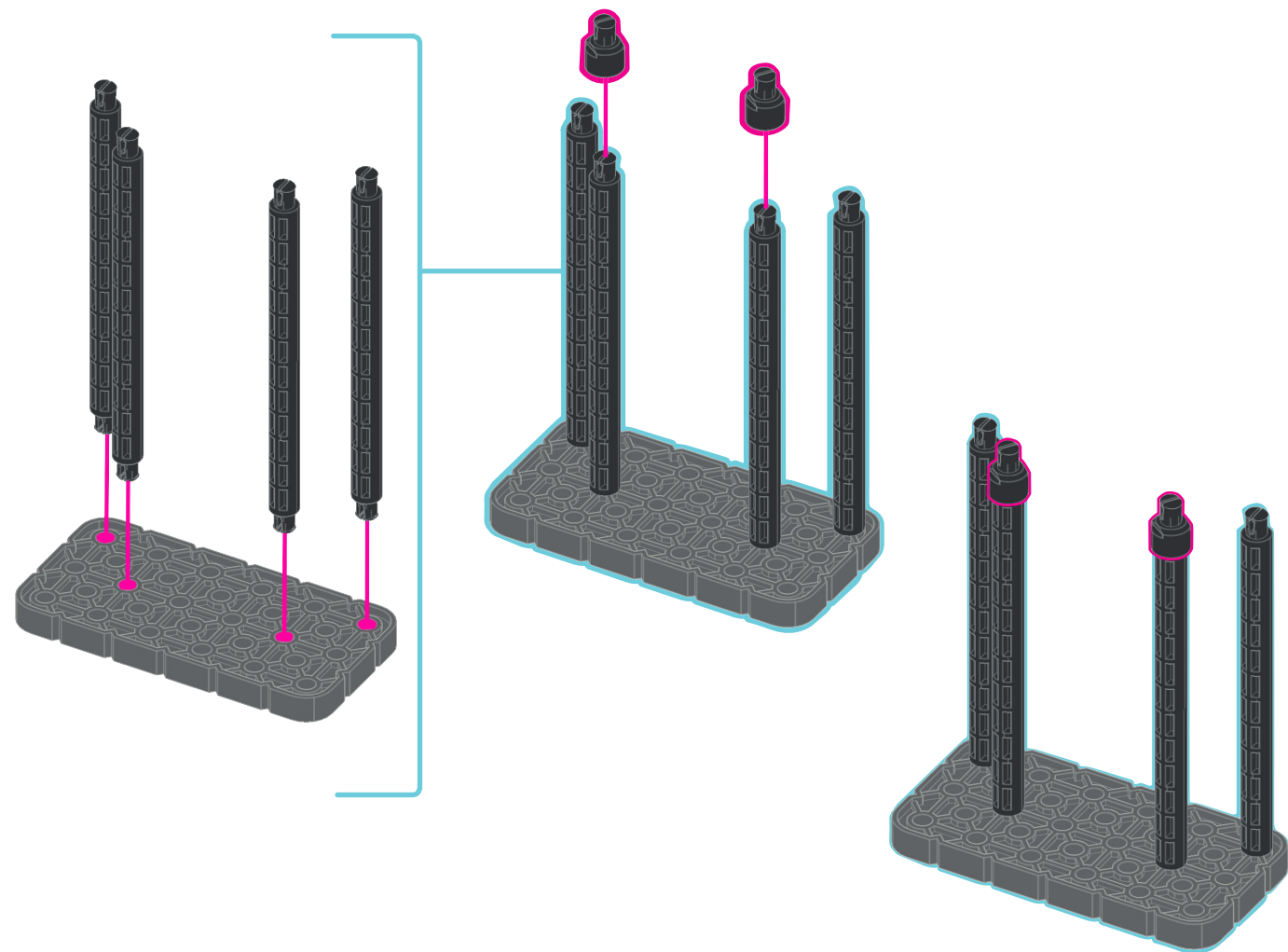

85

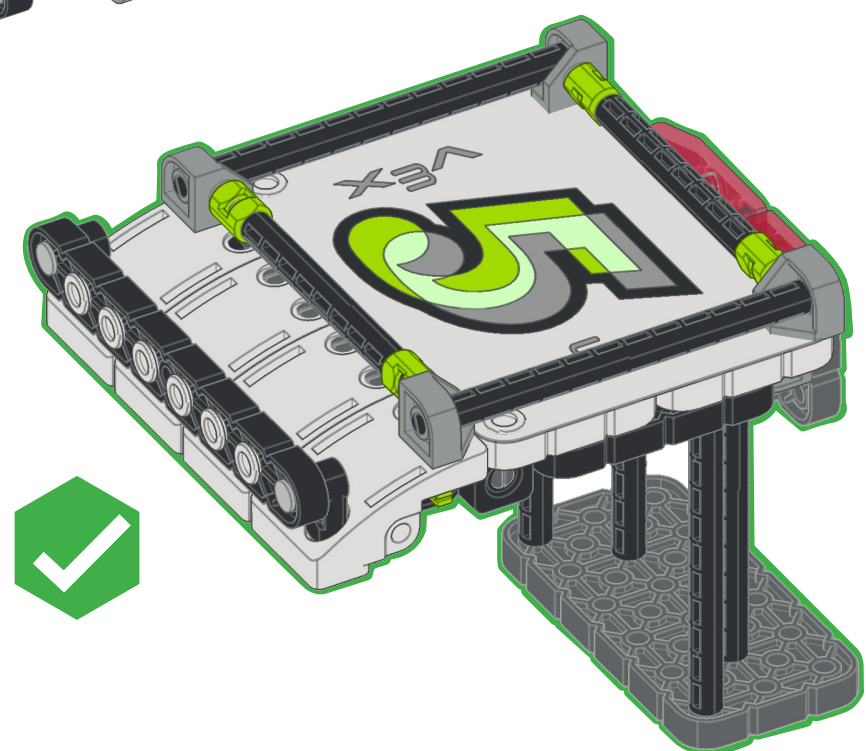
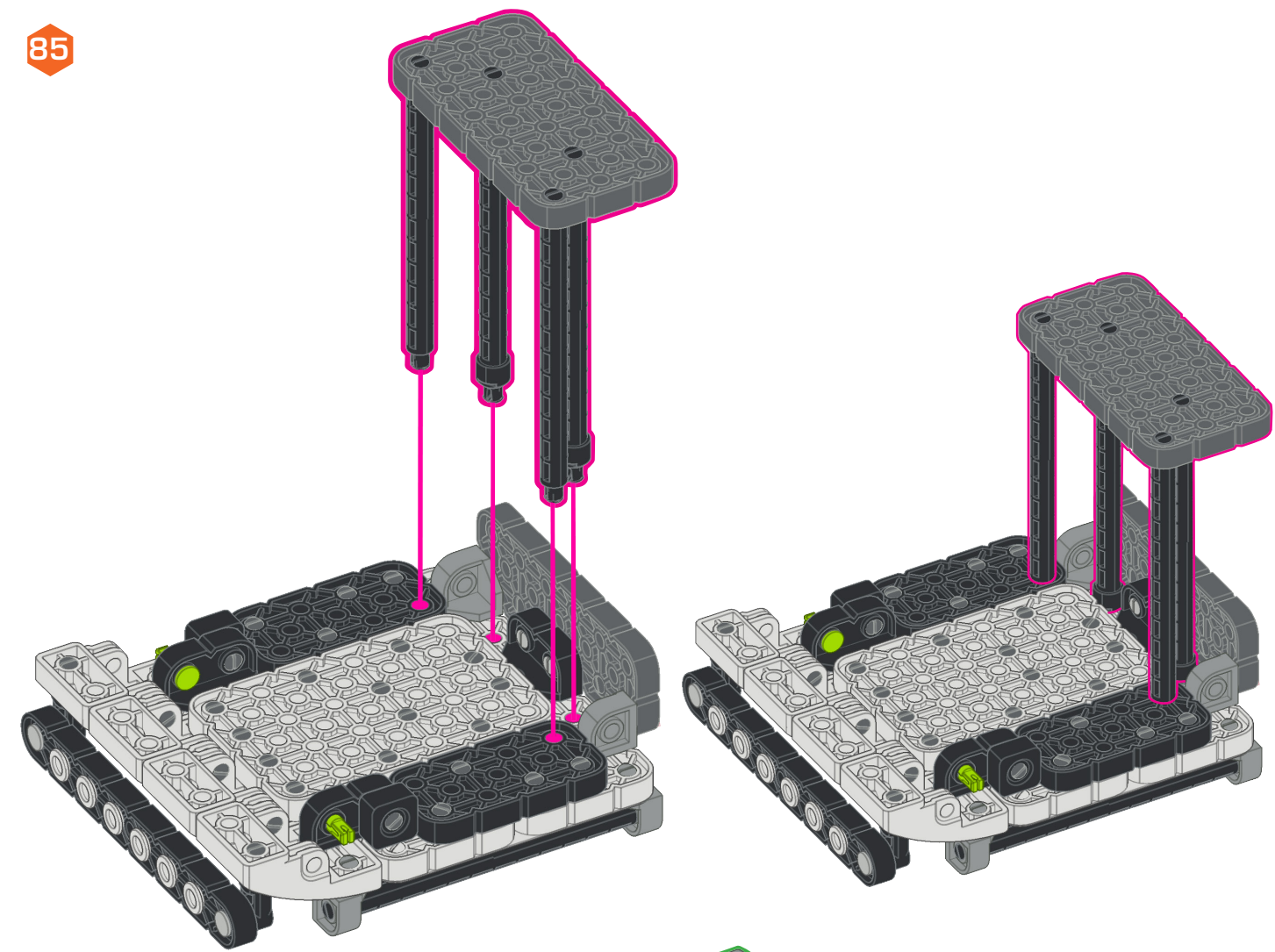

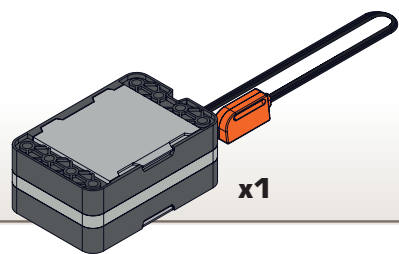

86

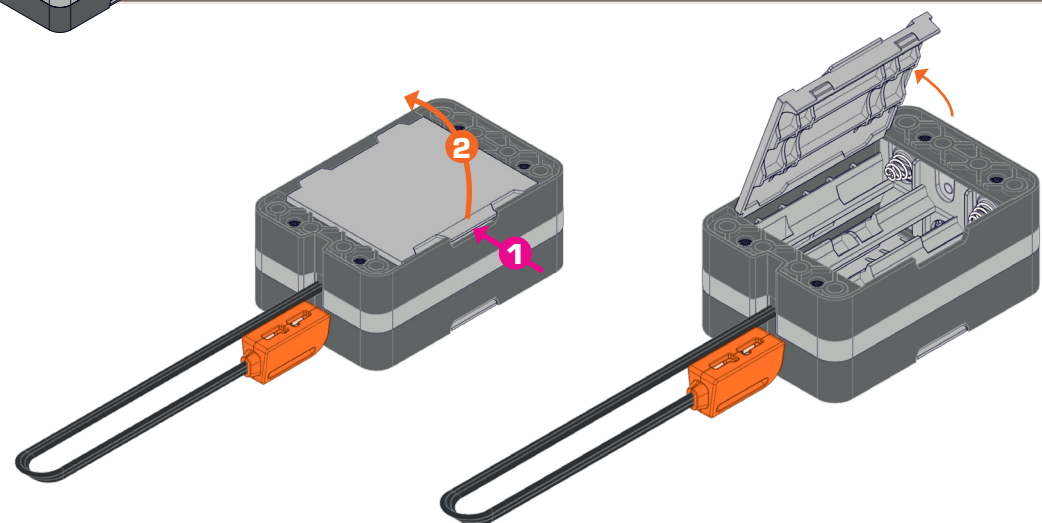

89

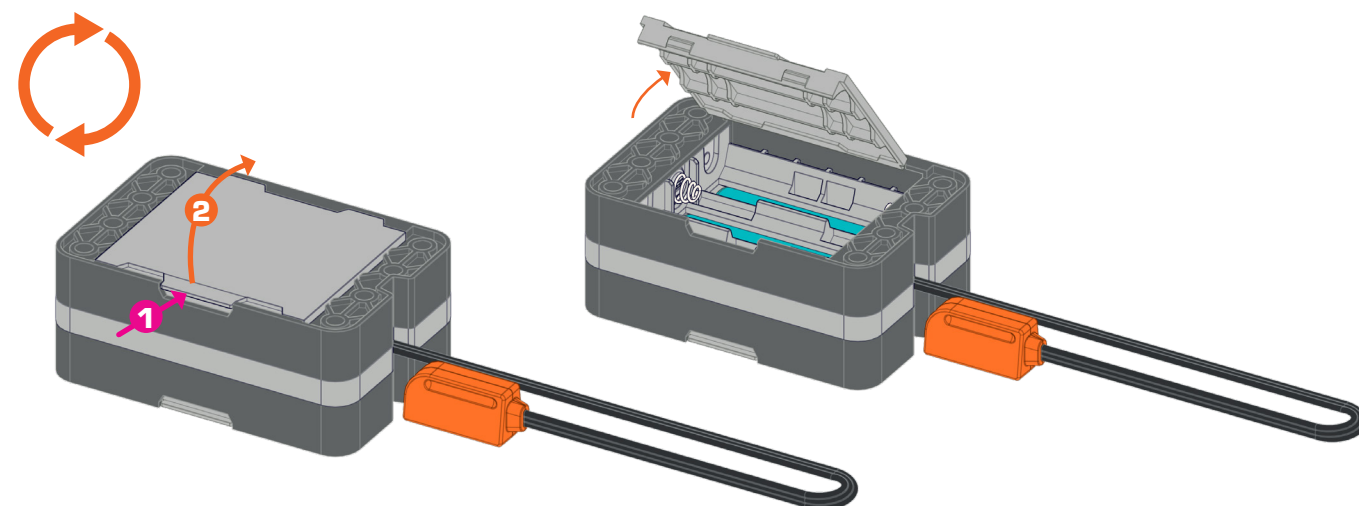

87

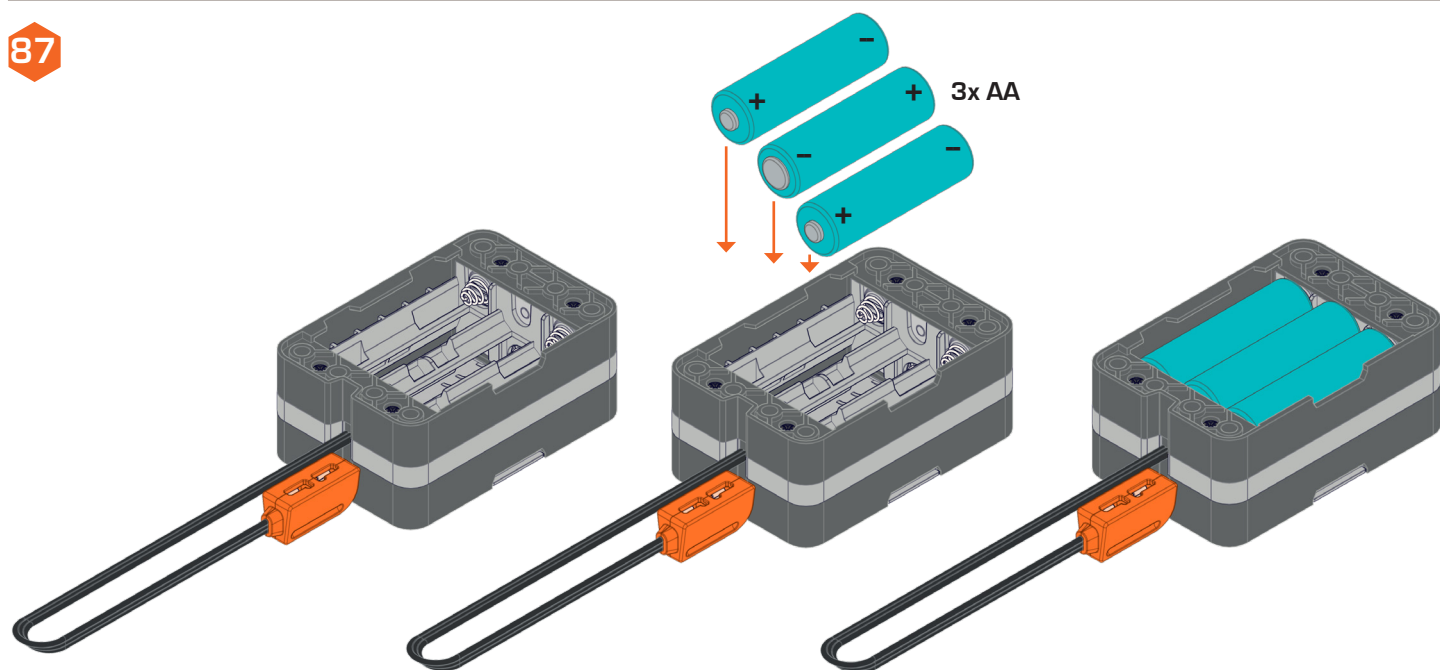

90

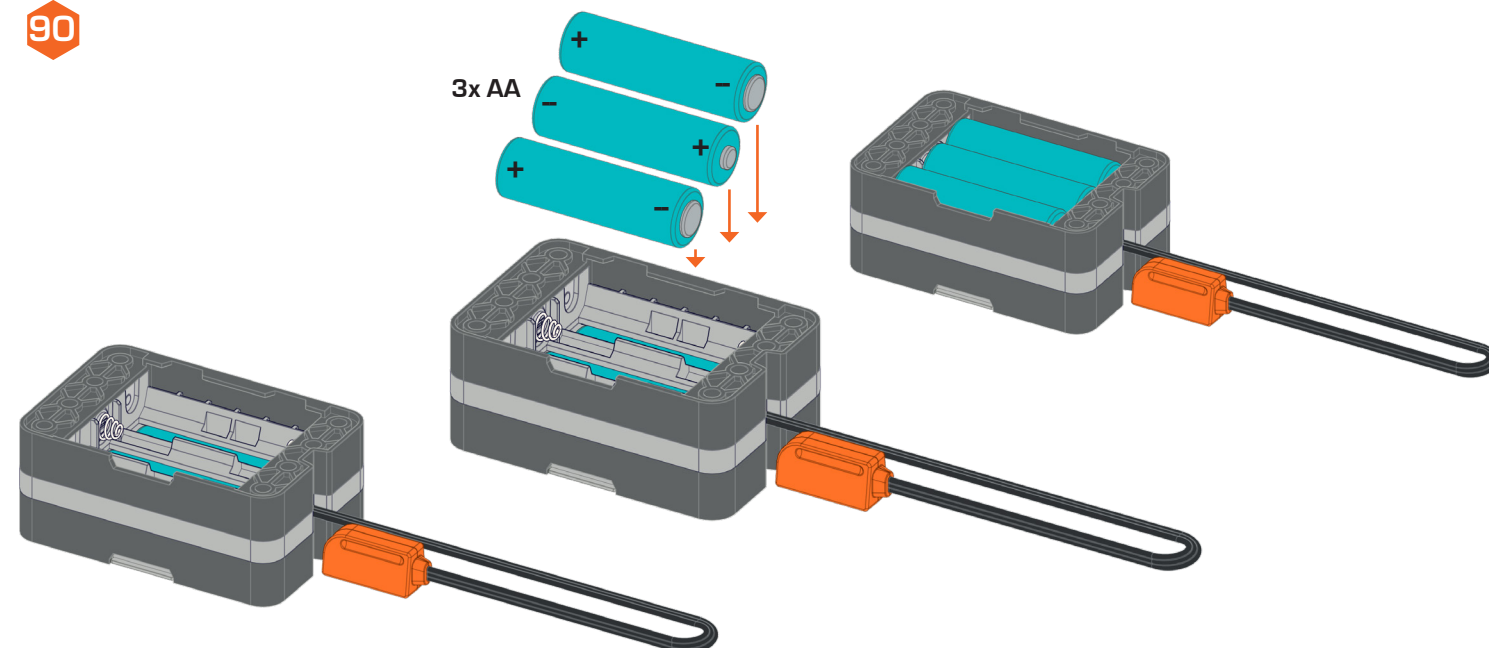

88

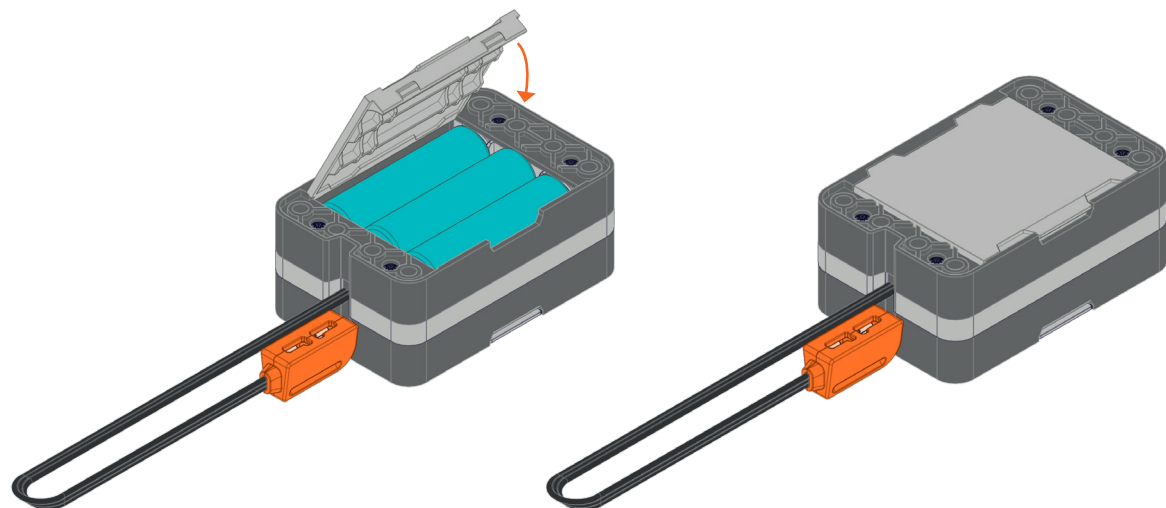

91

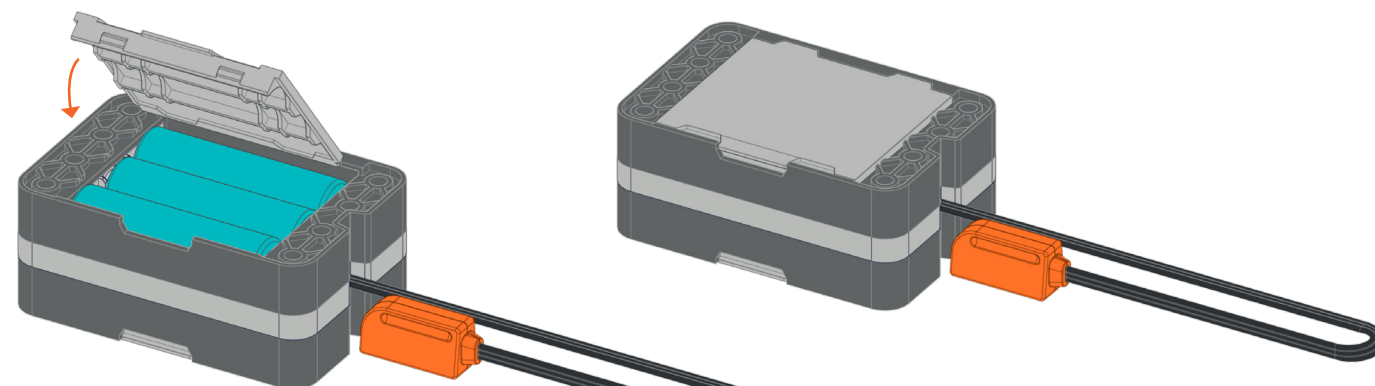

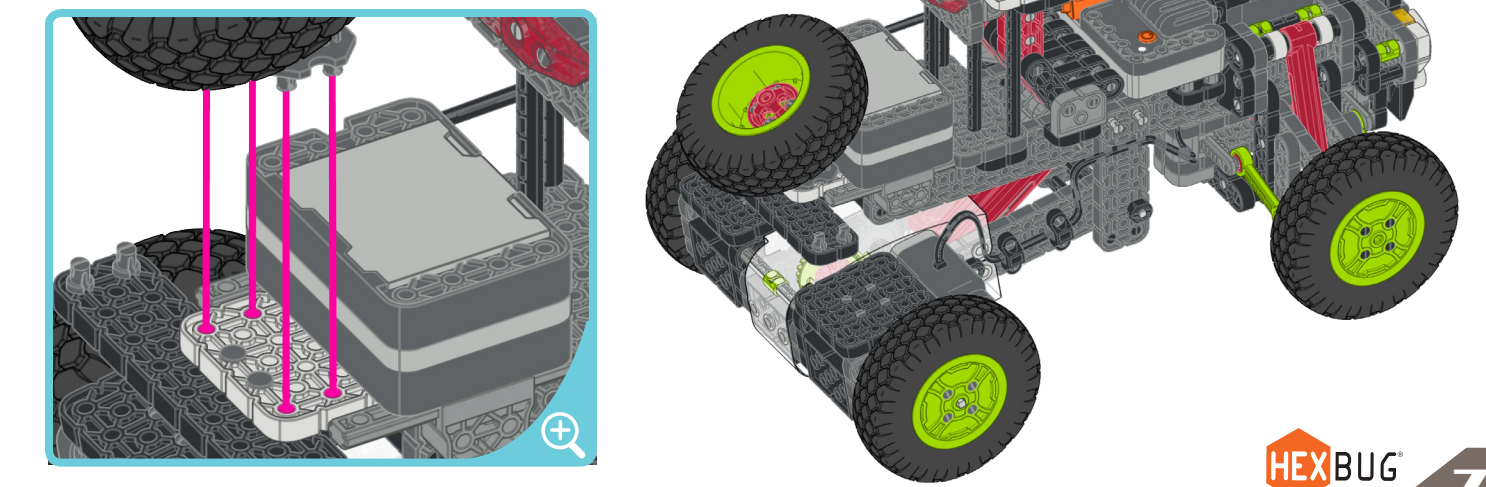
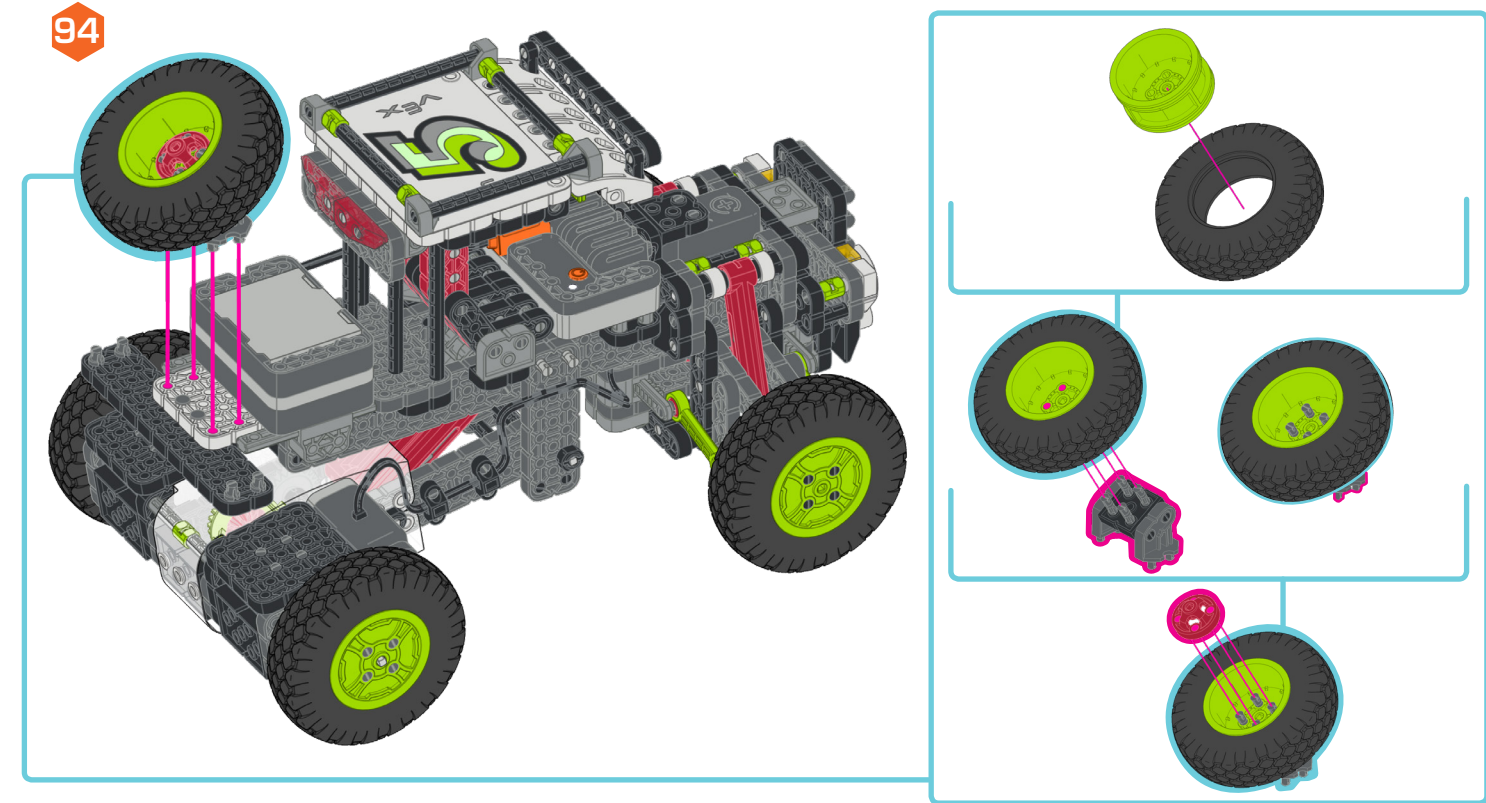
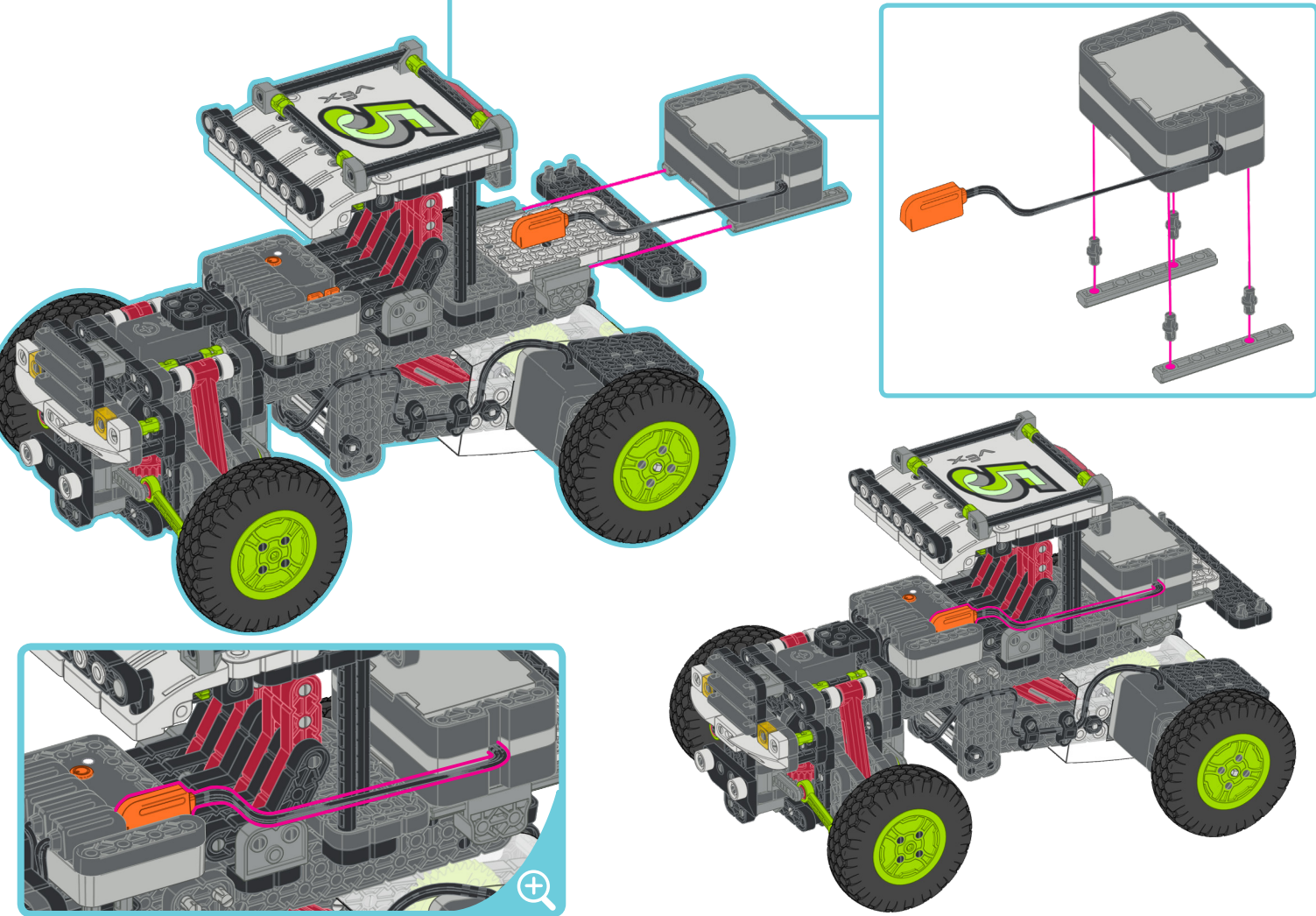
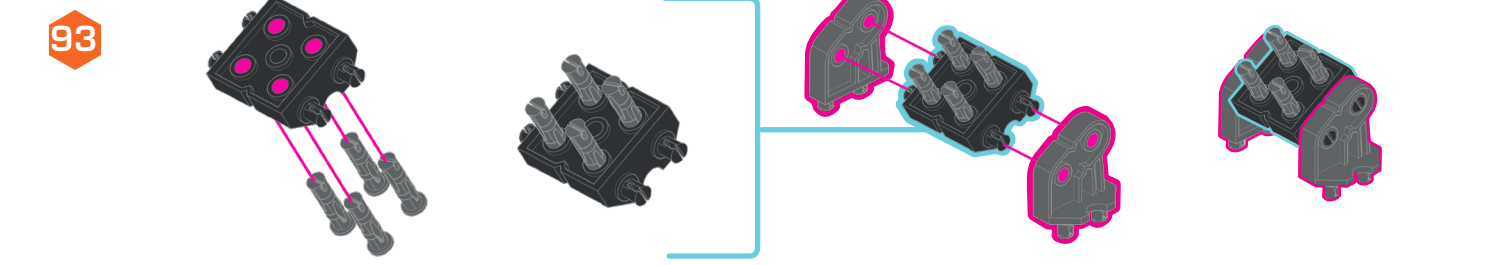
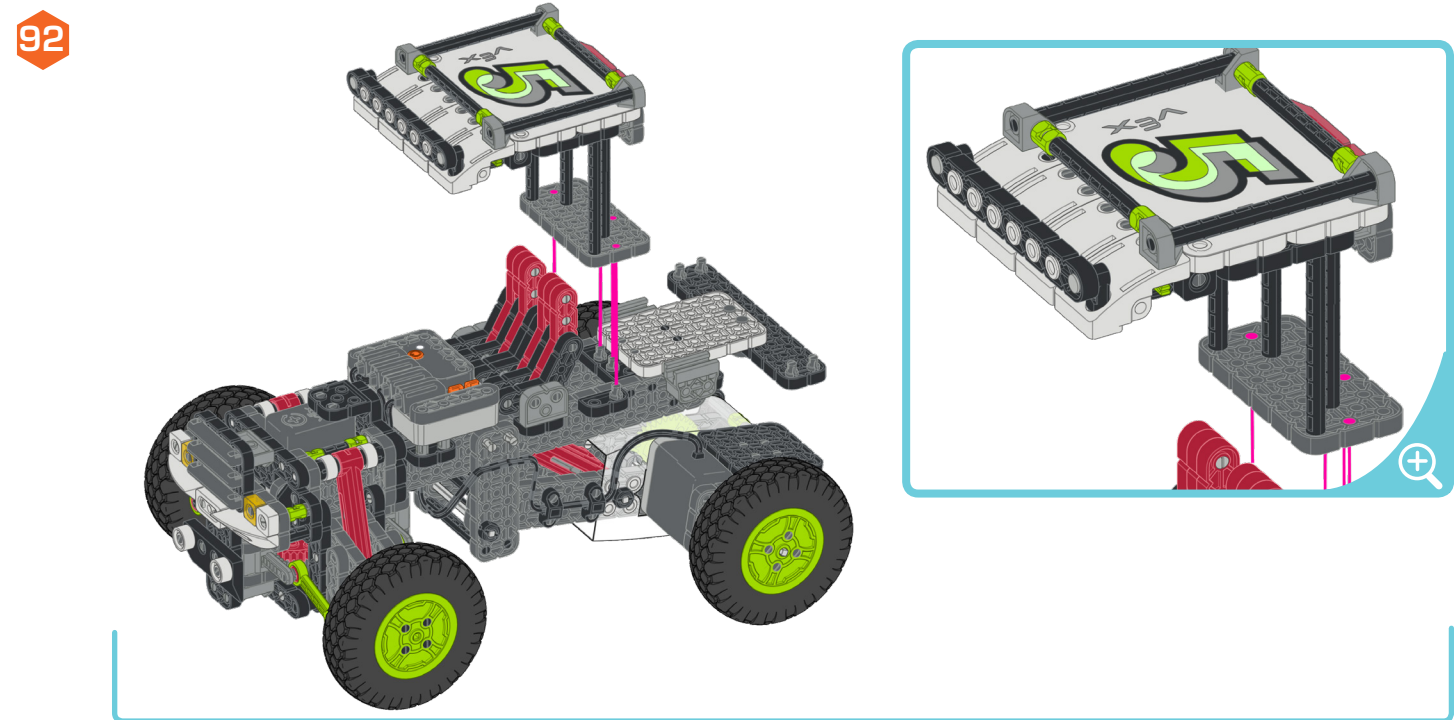
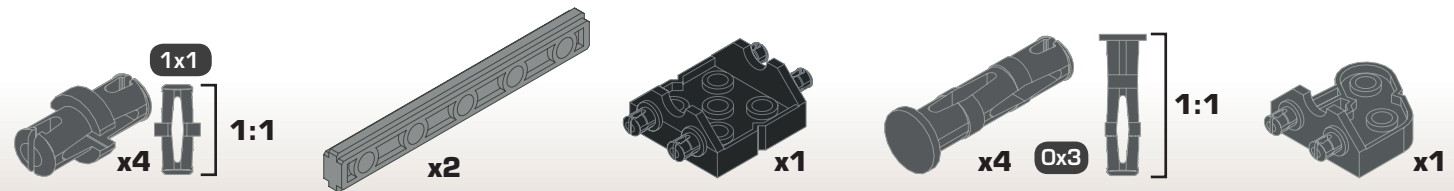

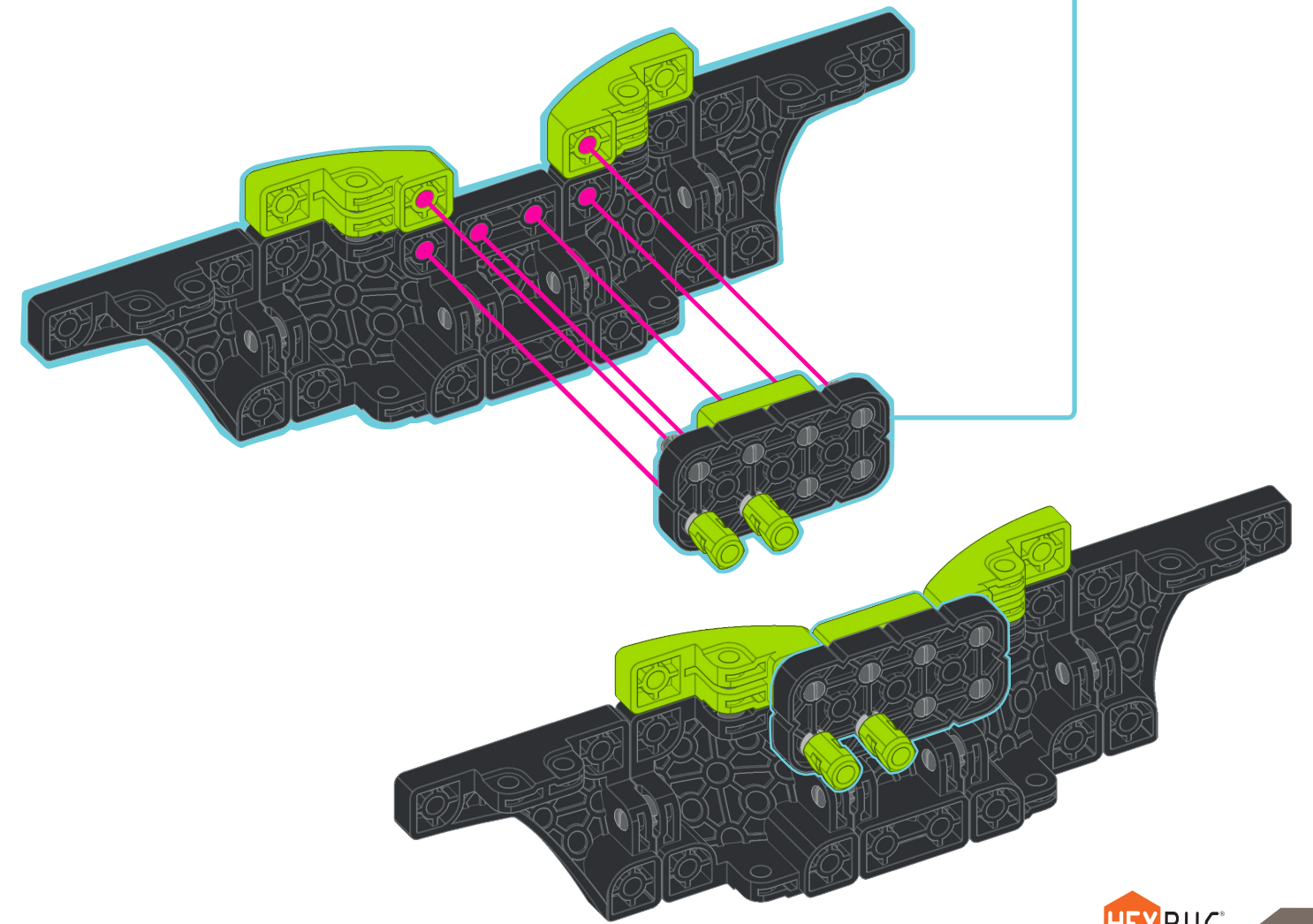
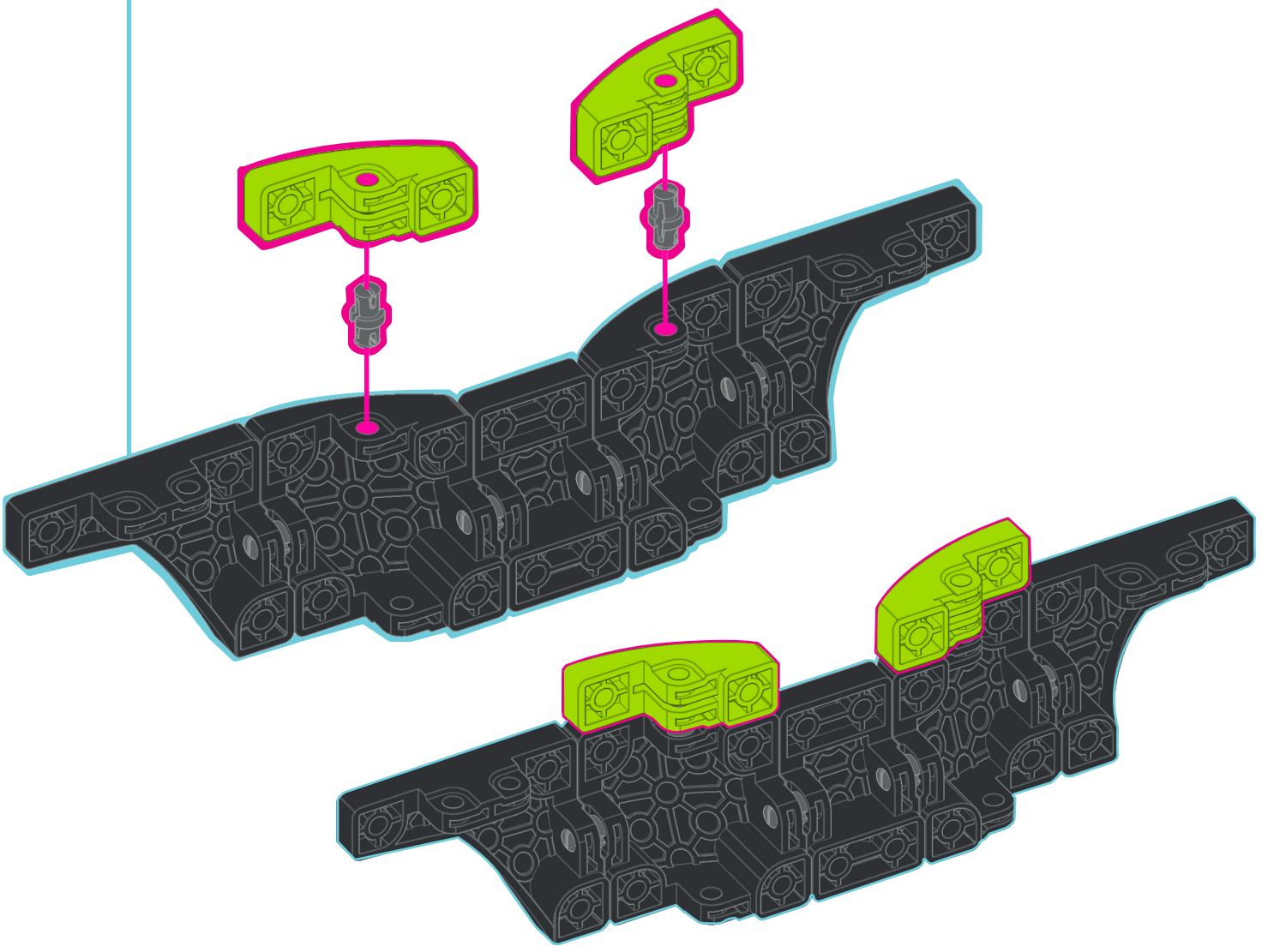
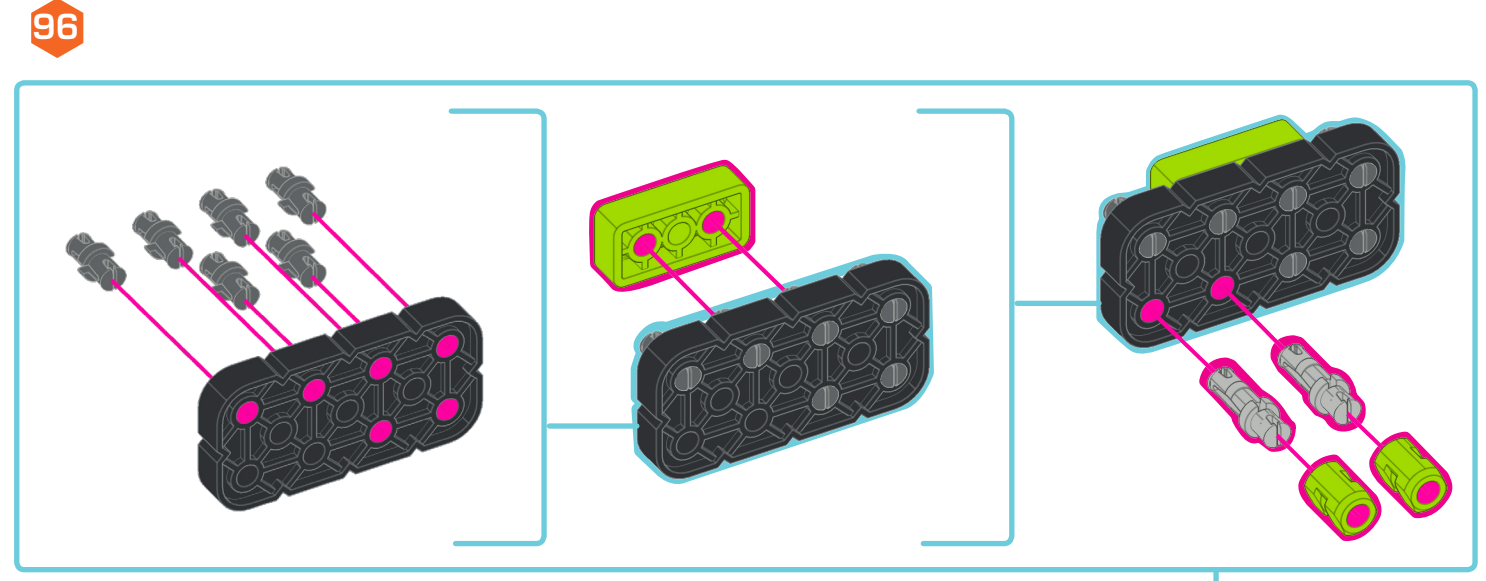
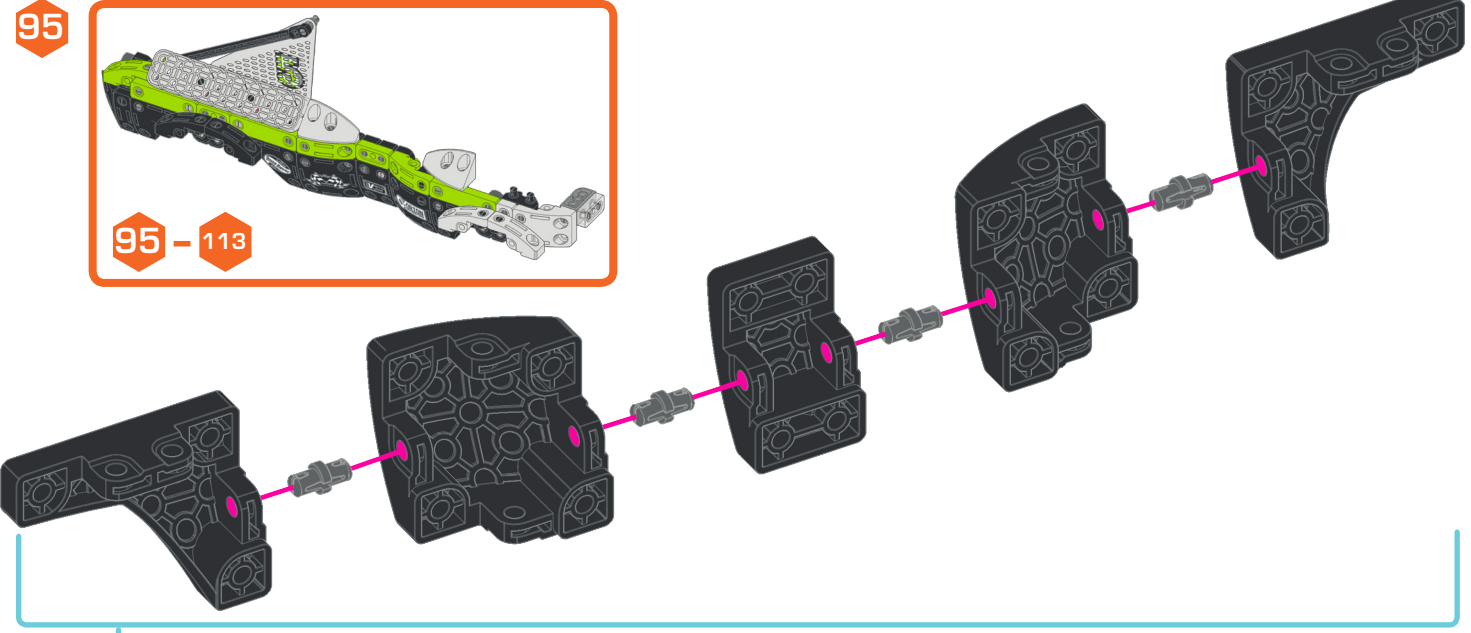
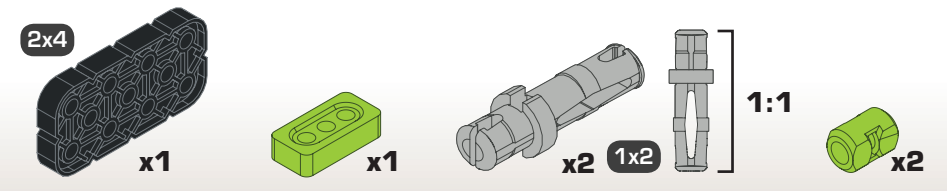
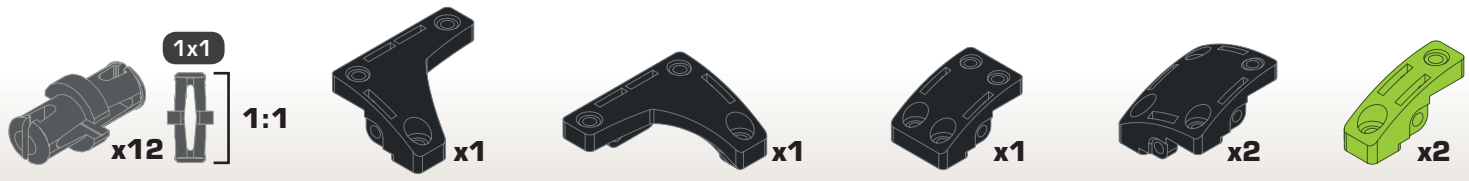

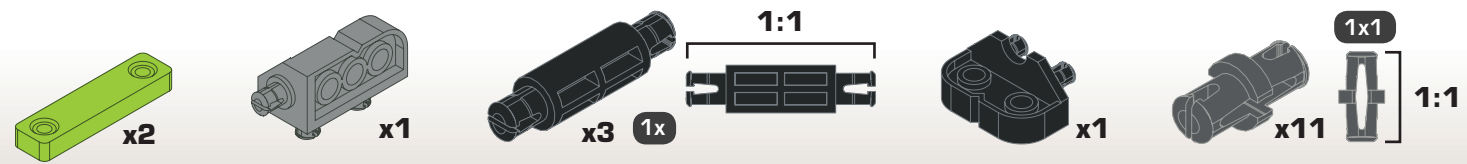

97

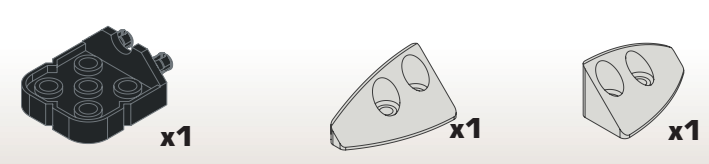
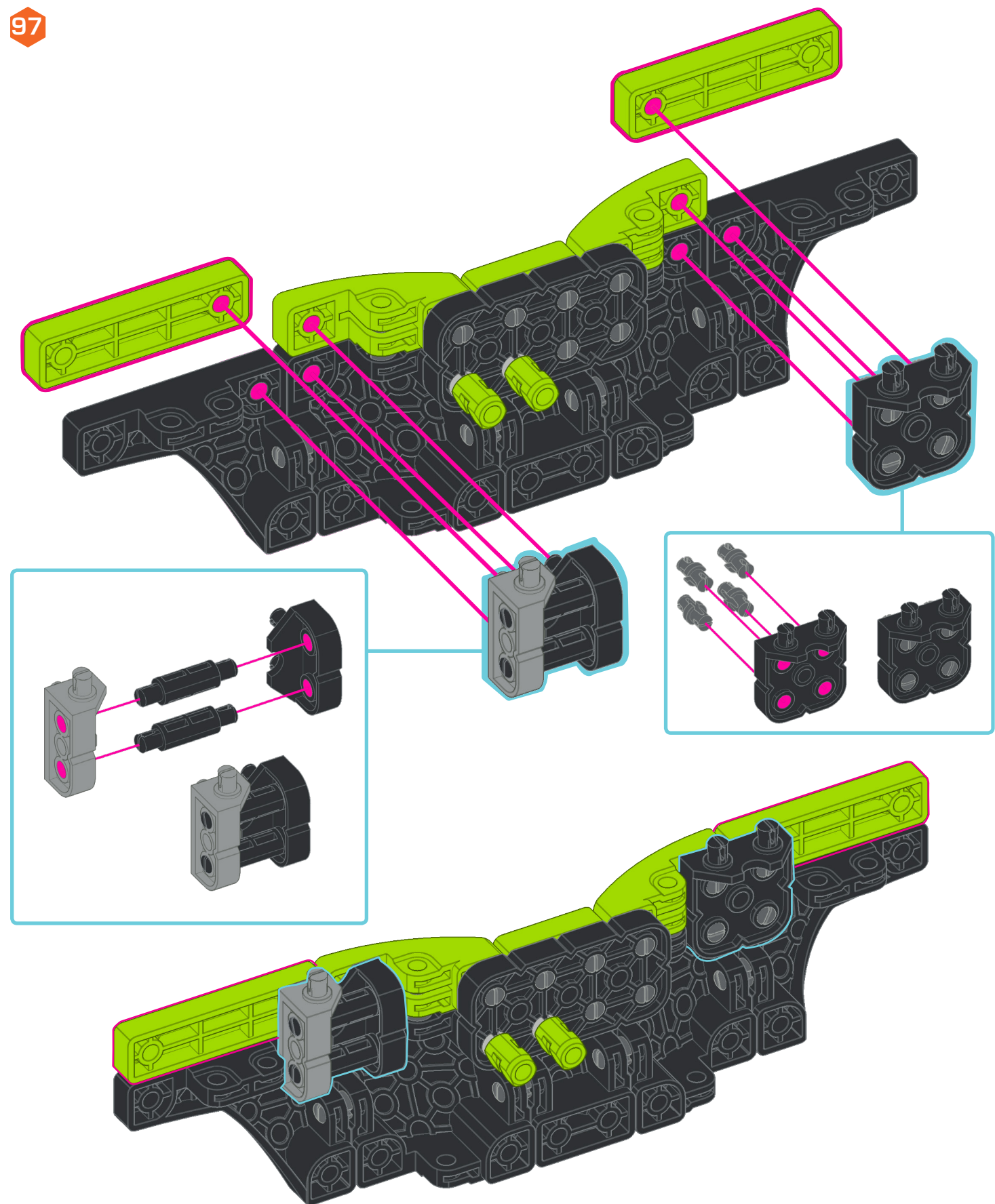

98

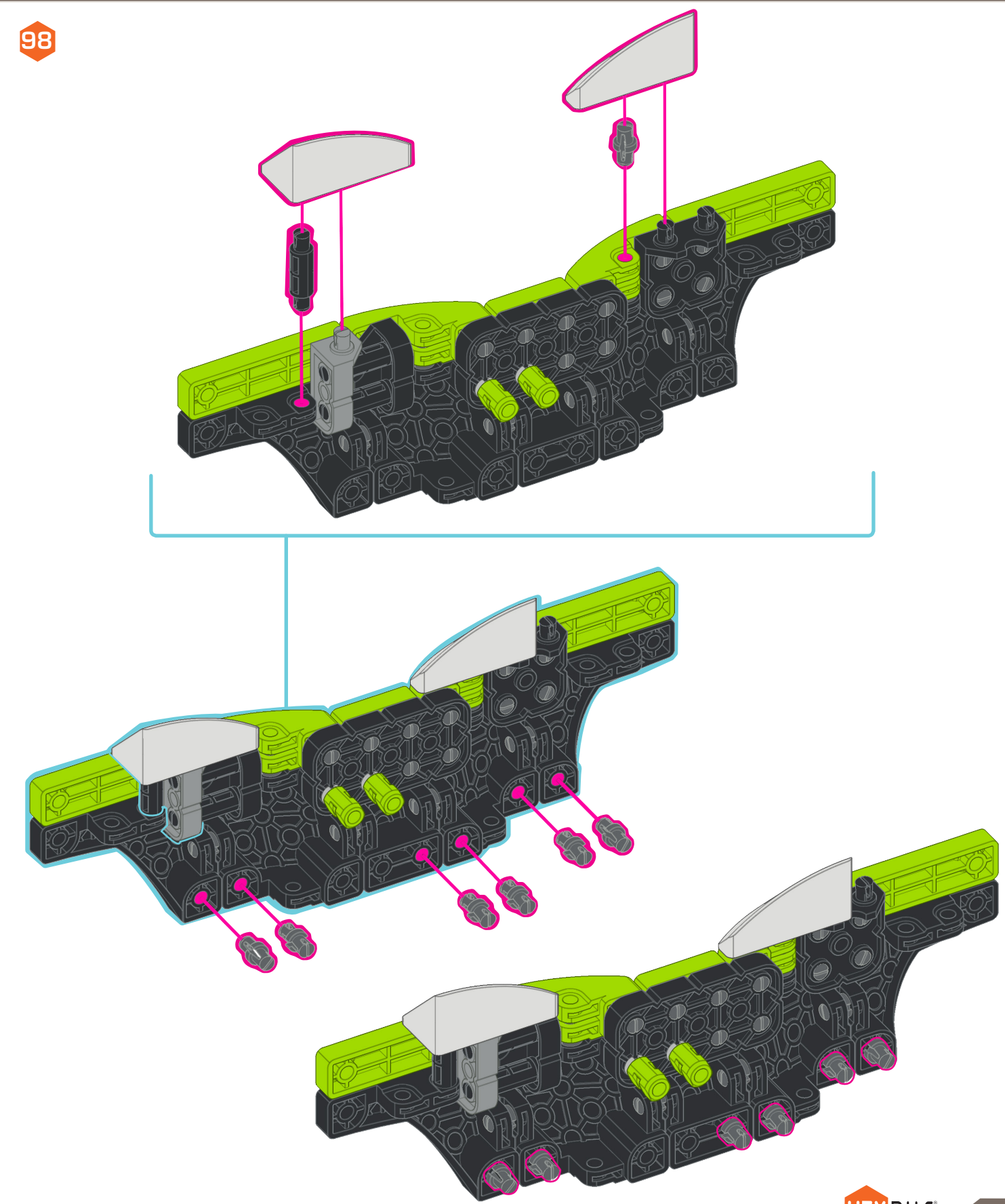

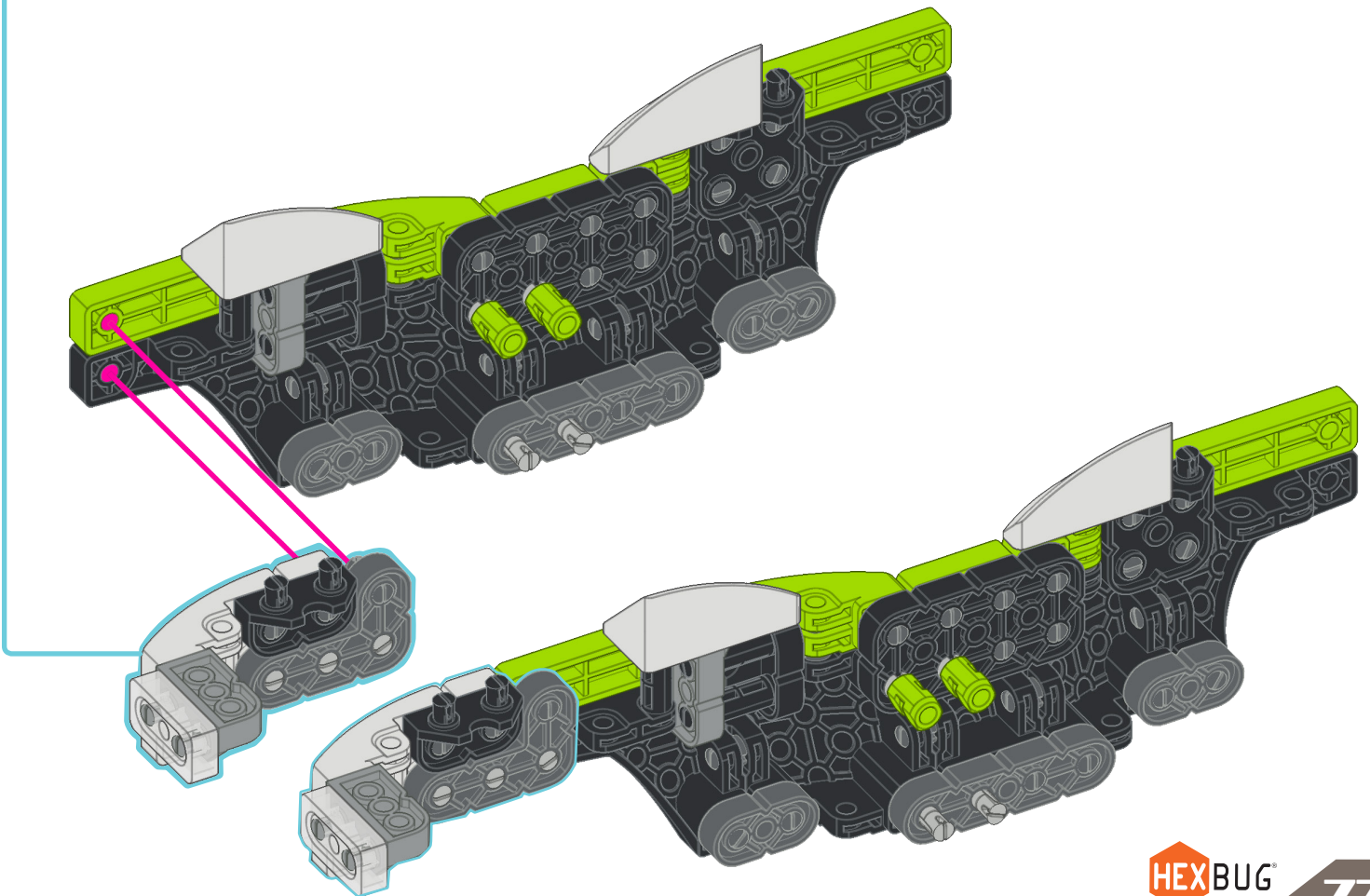
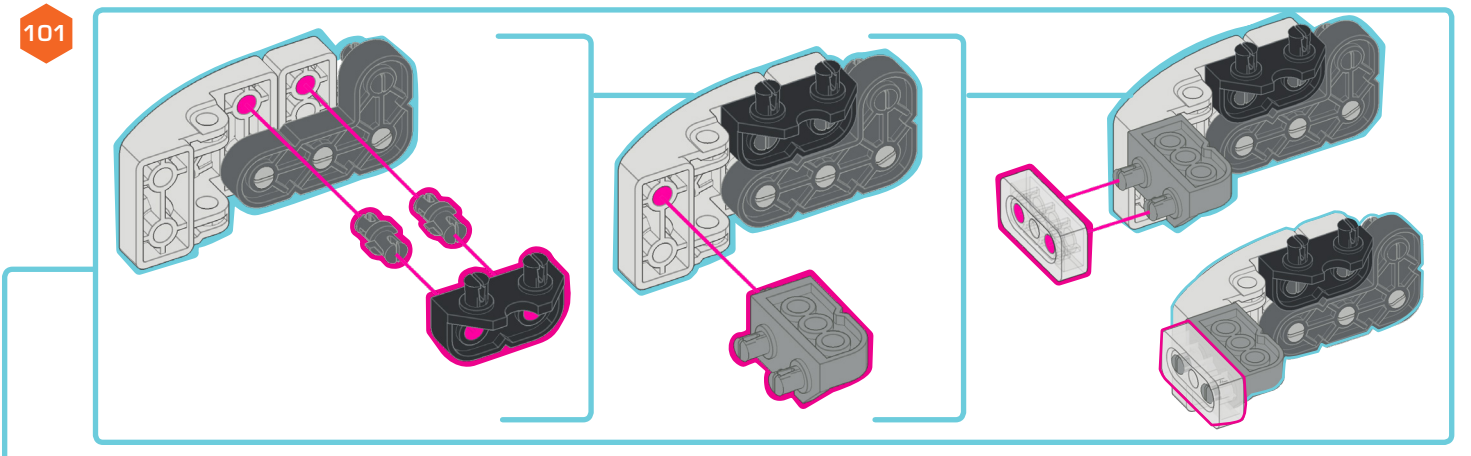
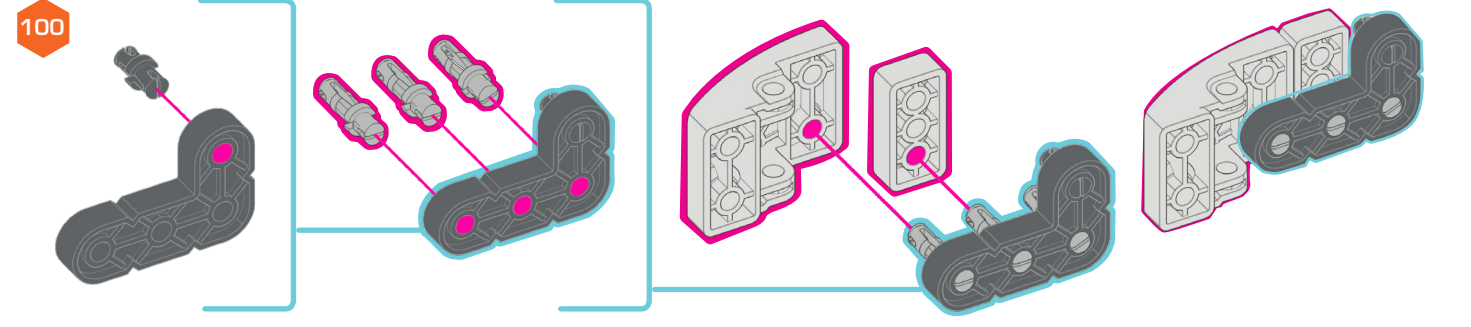
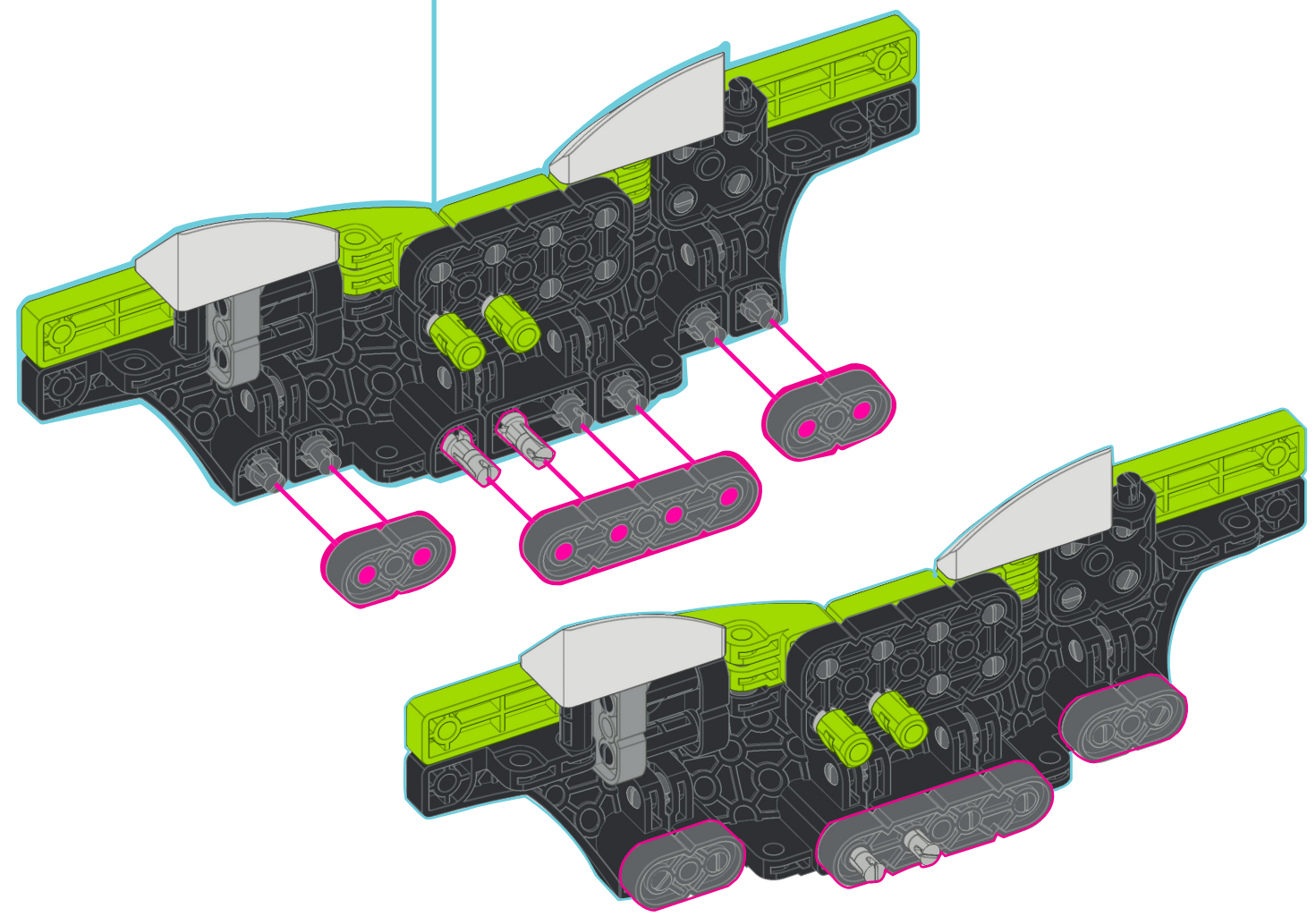
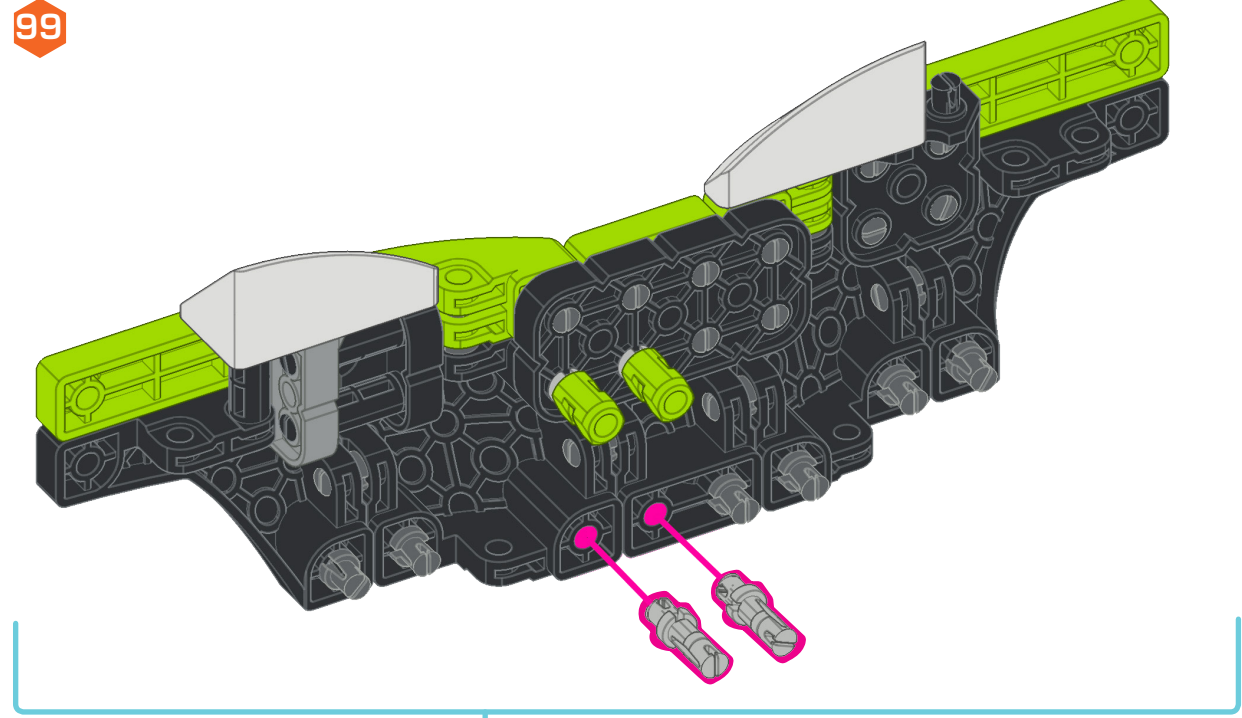
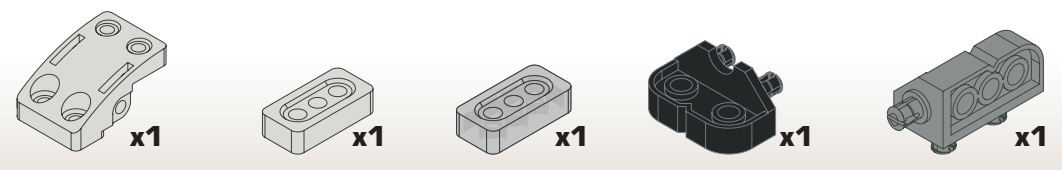

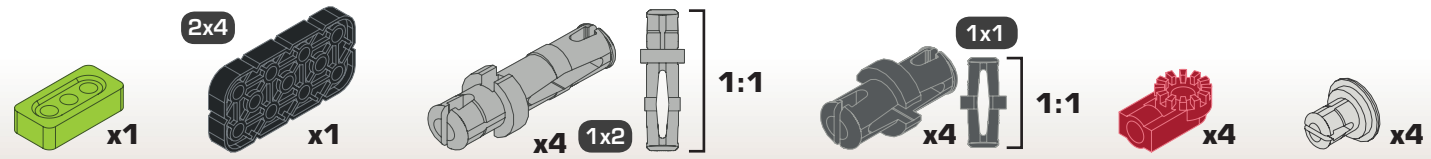

102

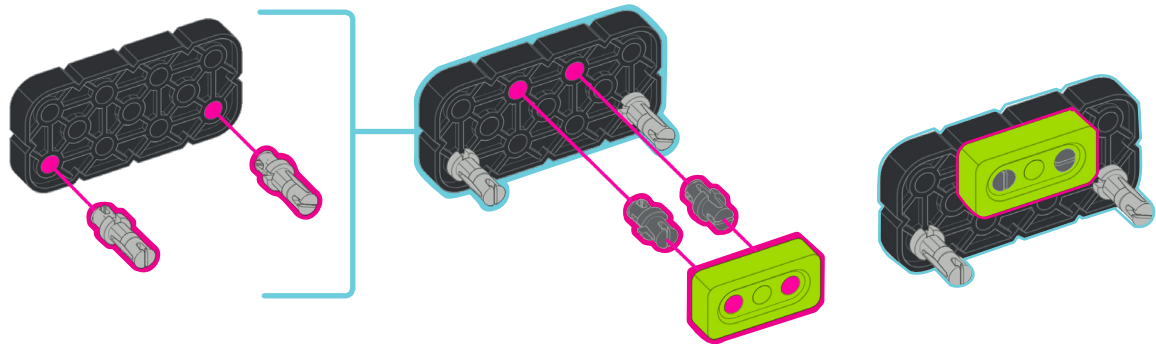

105

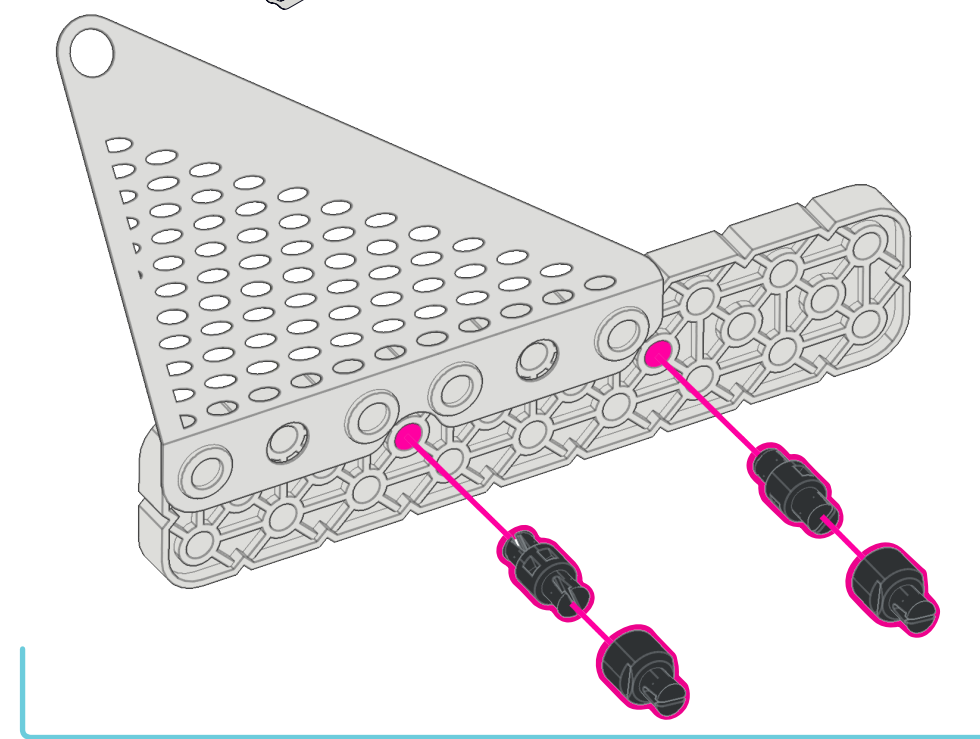
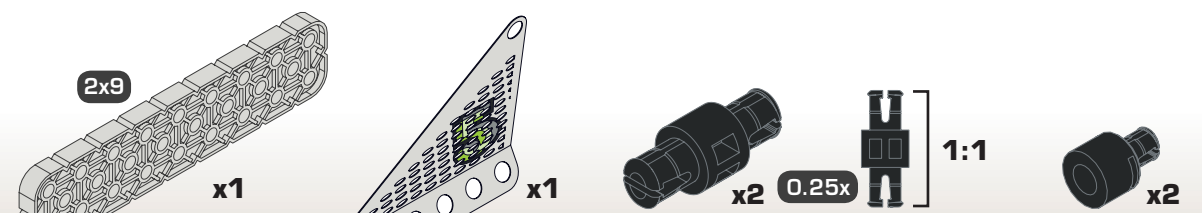

103

2X

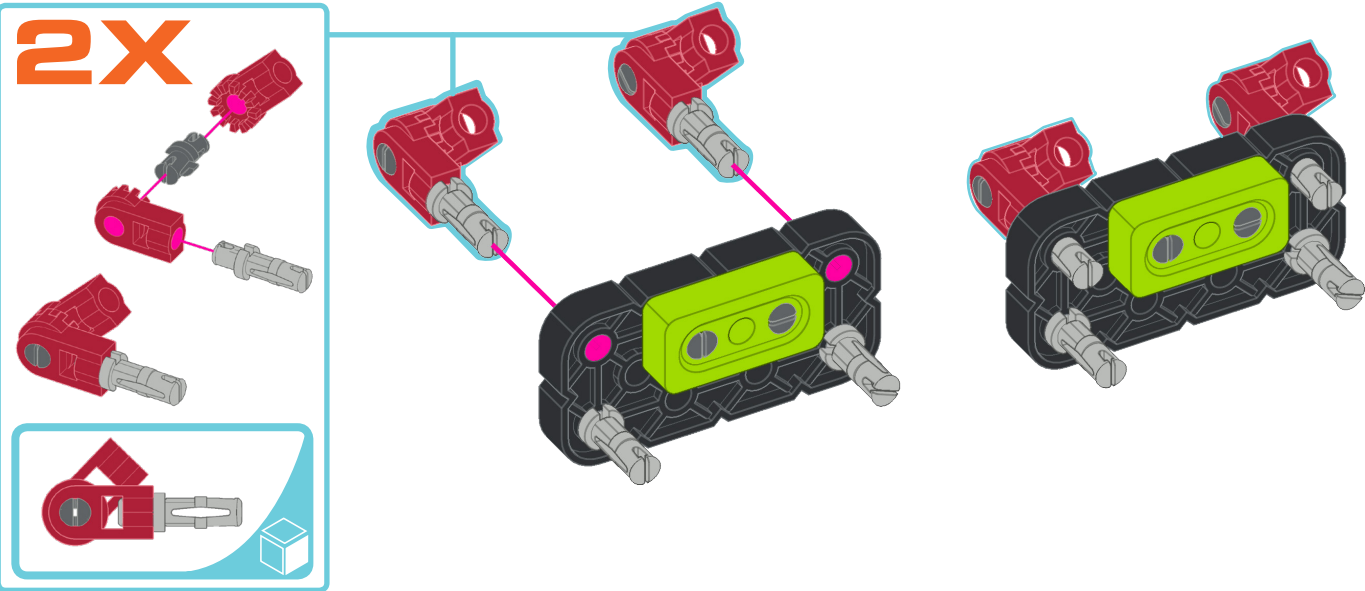

104

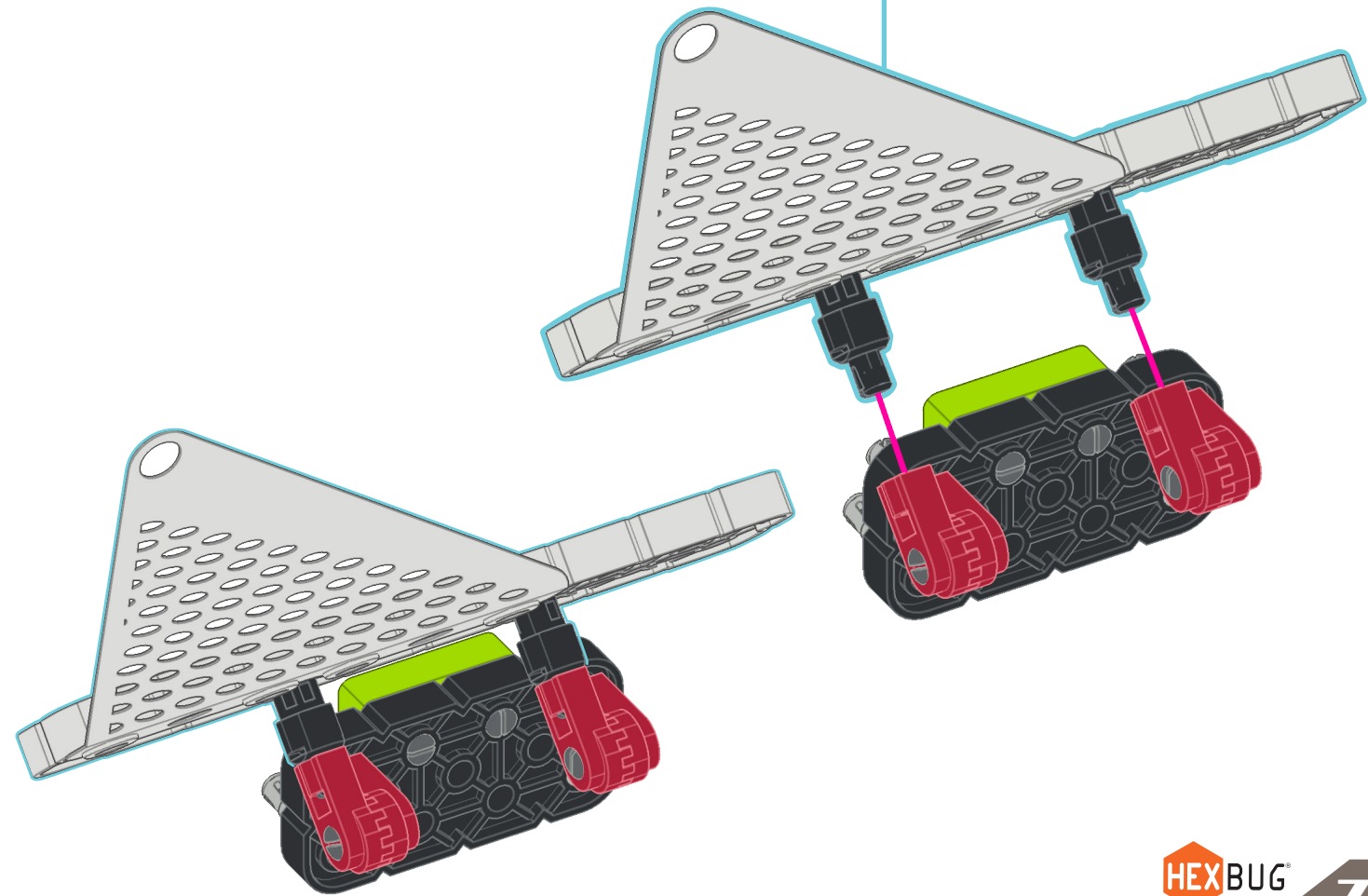
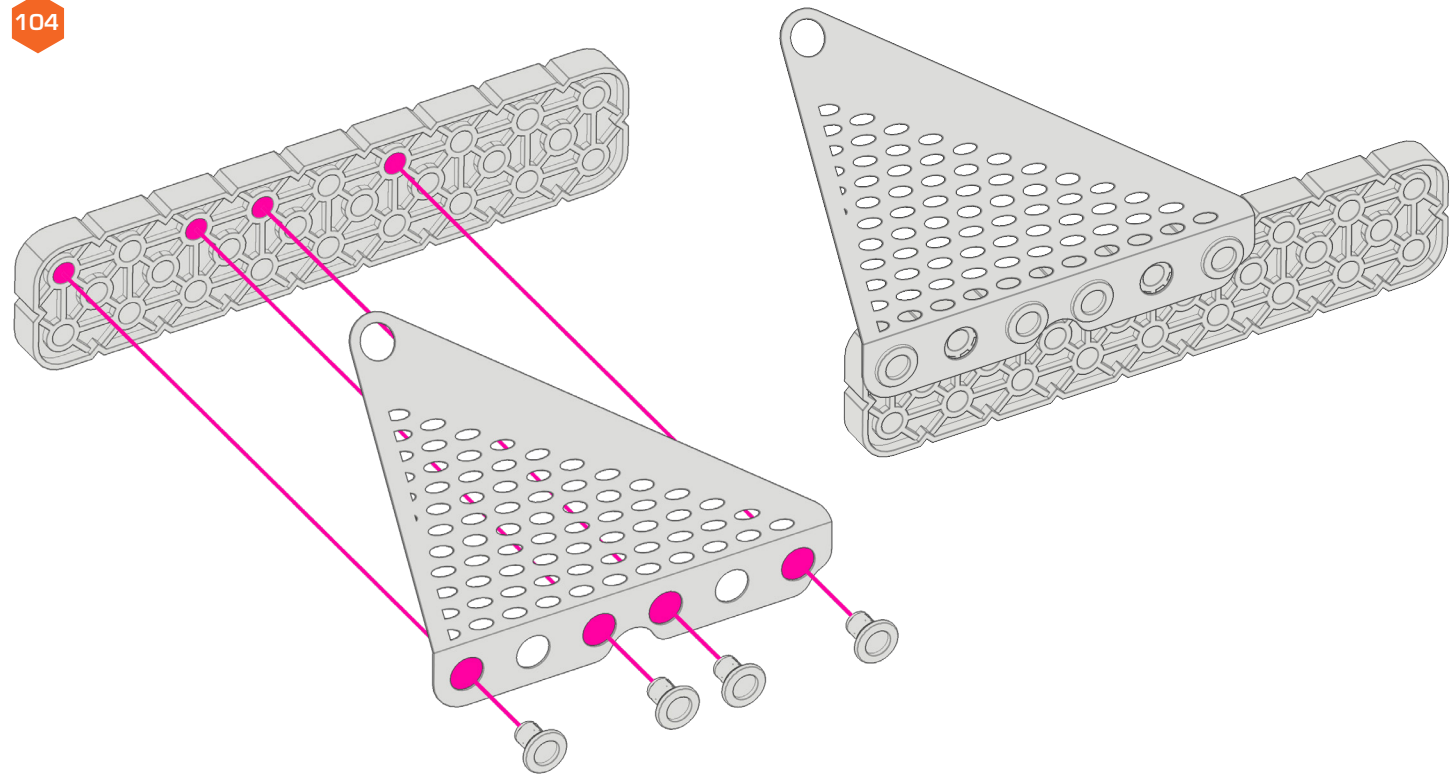

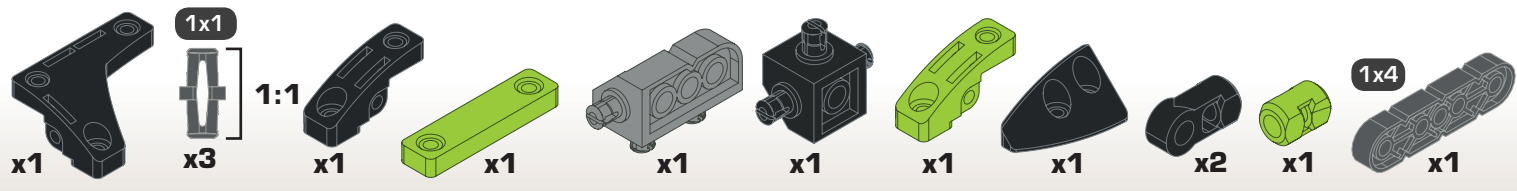

106

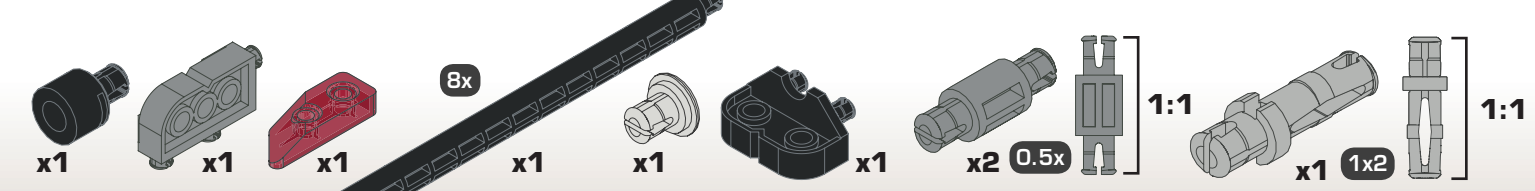
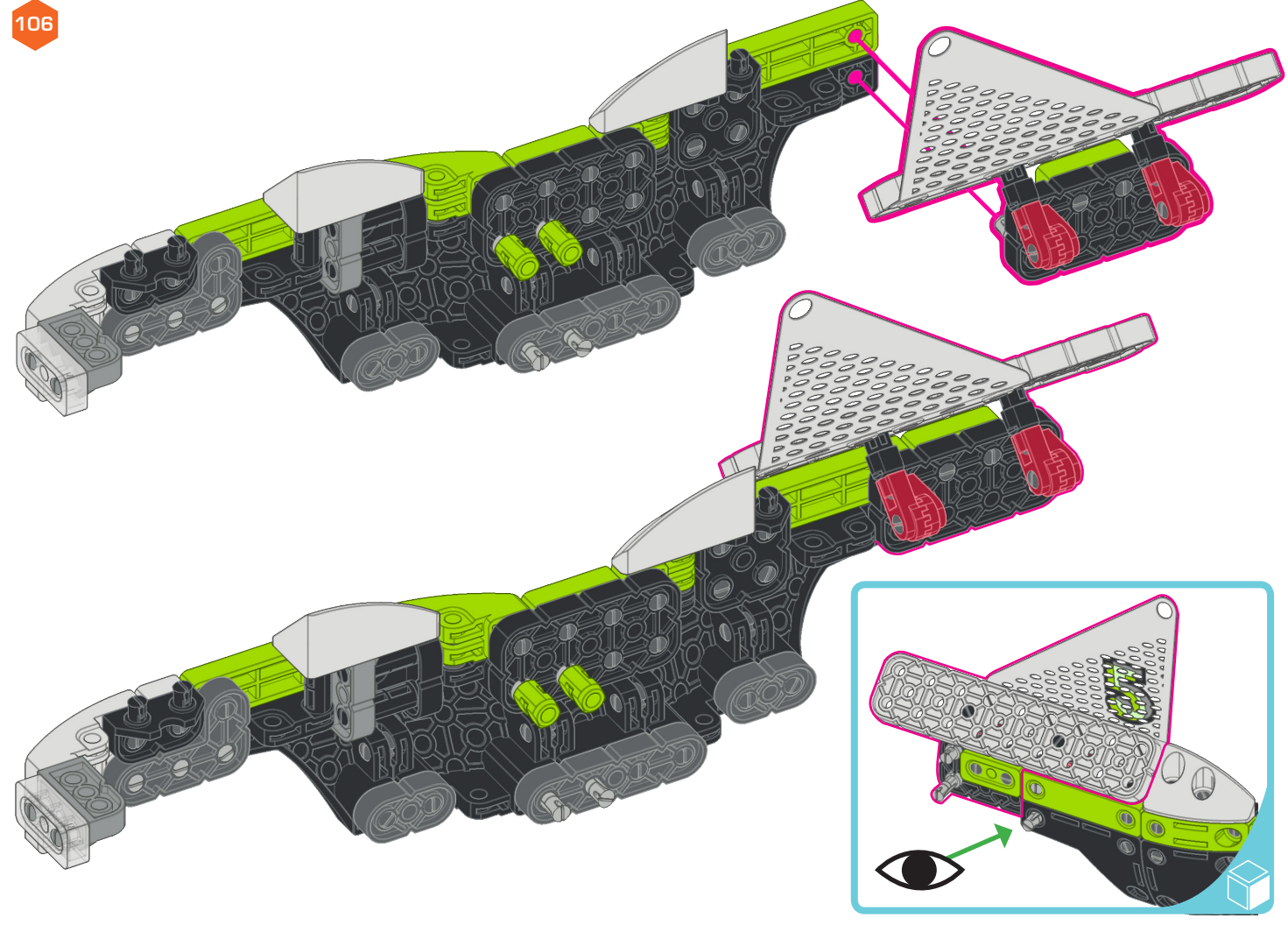

110

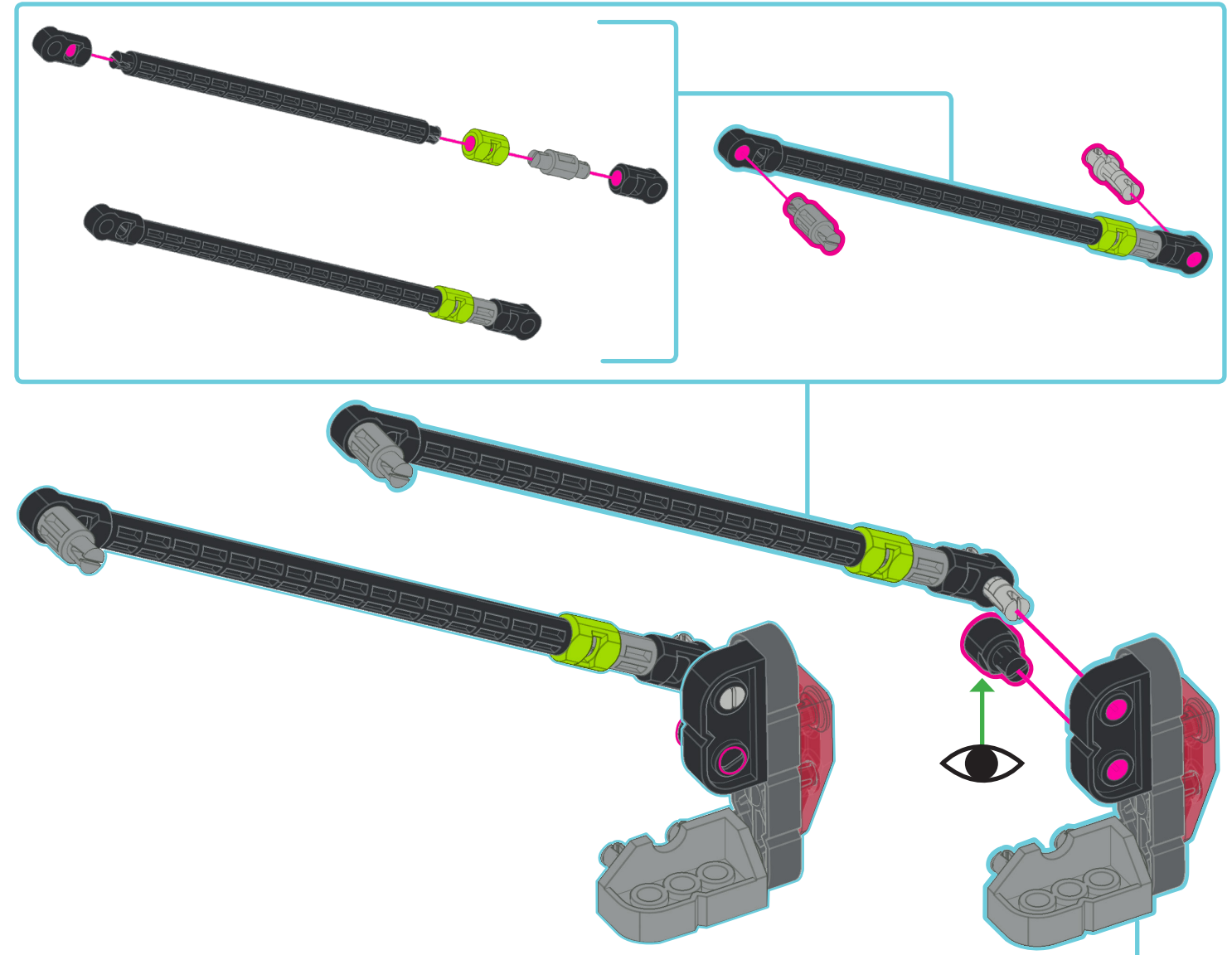

107

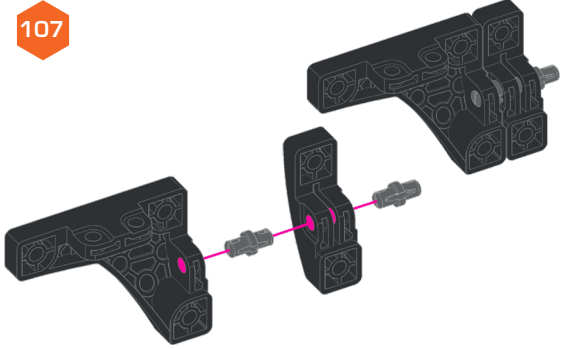

108

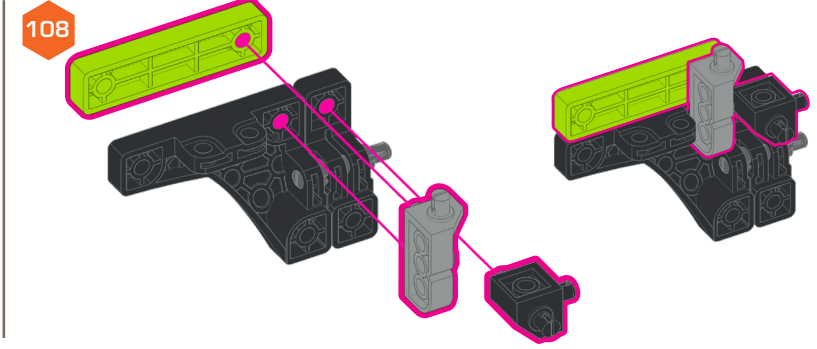

109

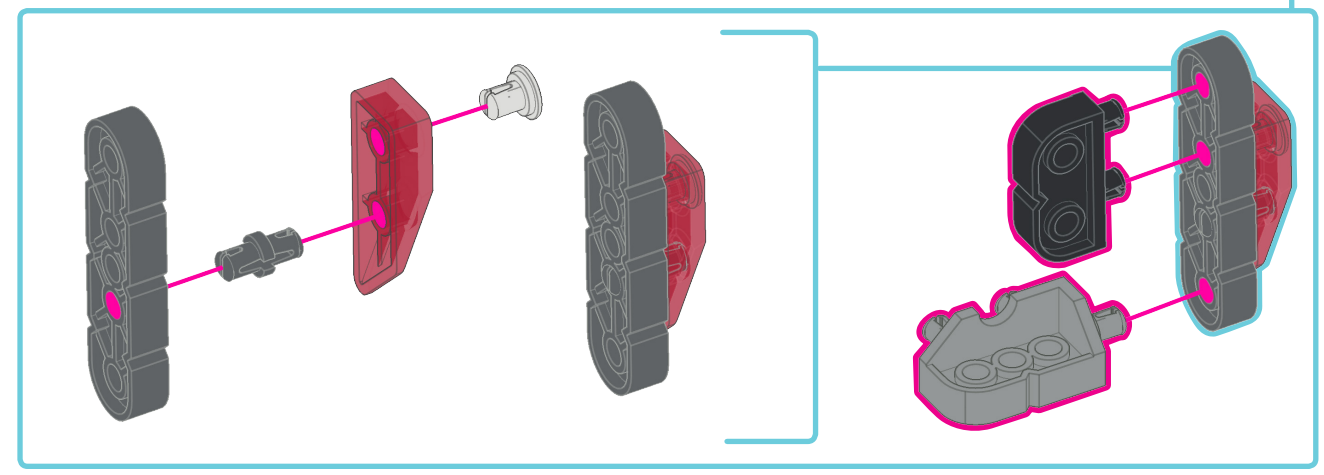
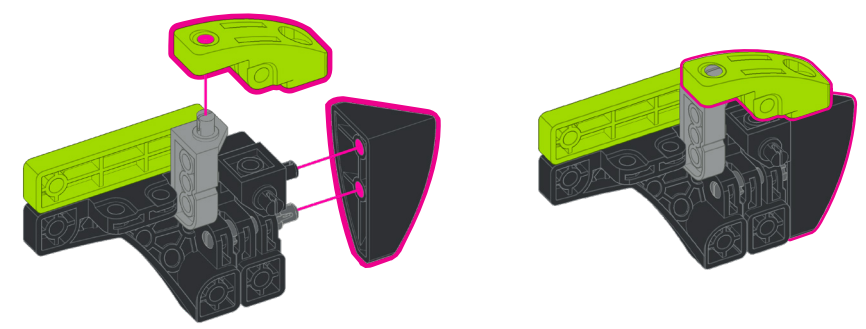

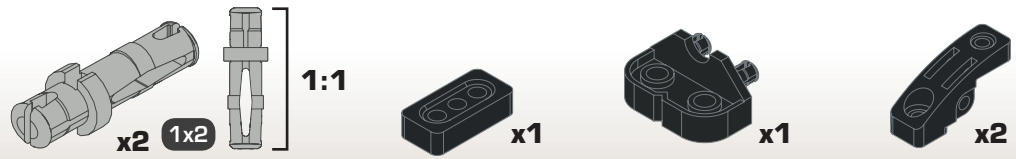

111

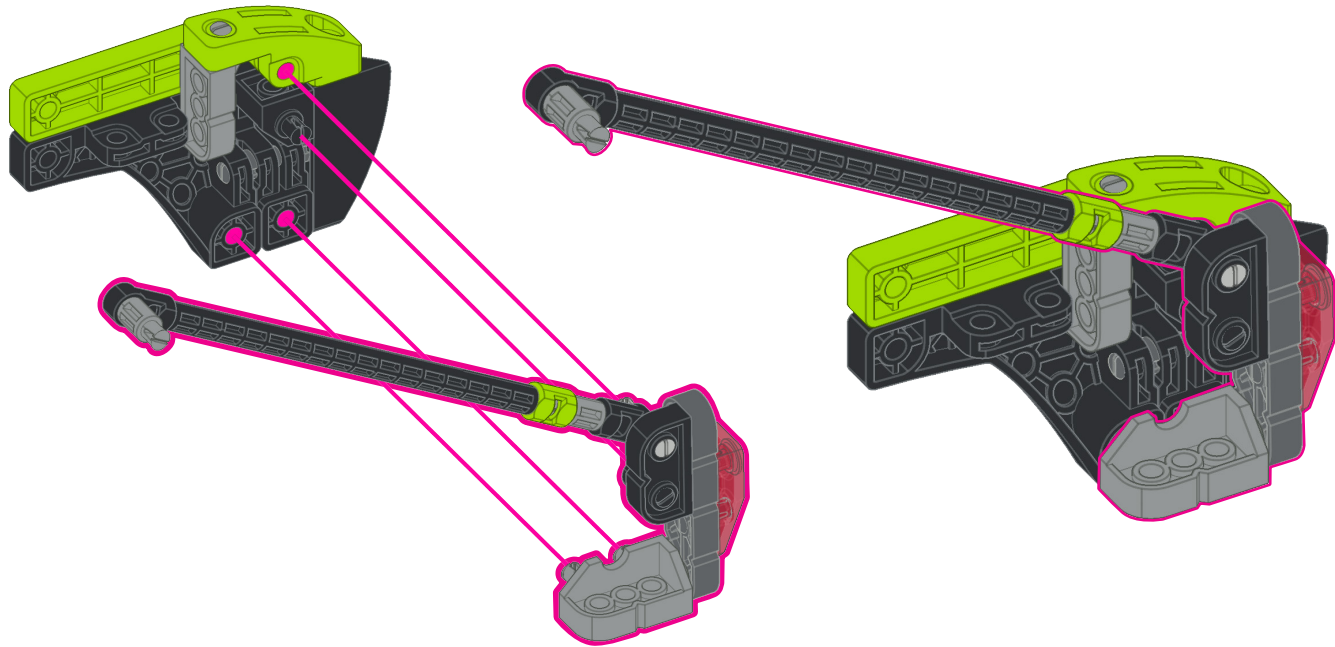

112

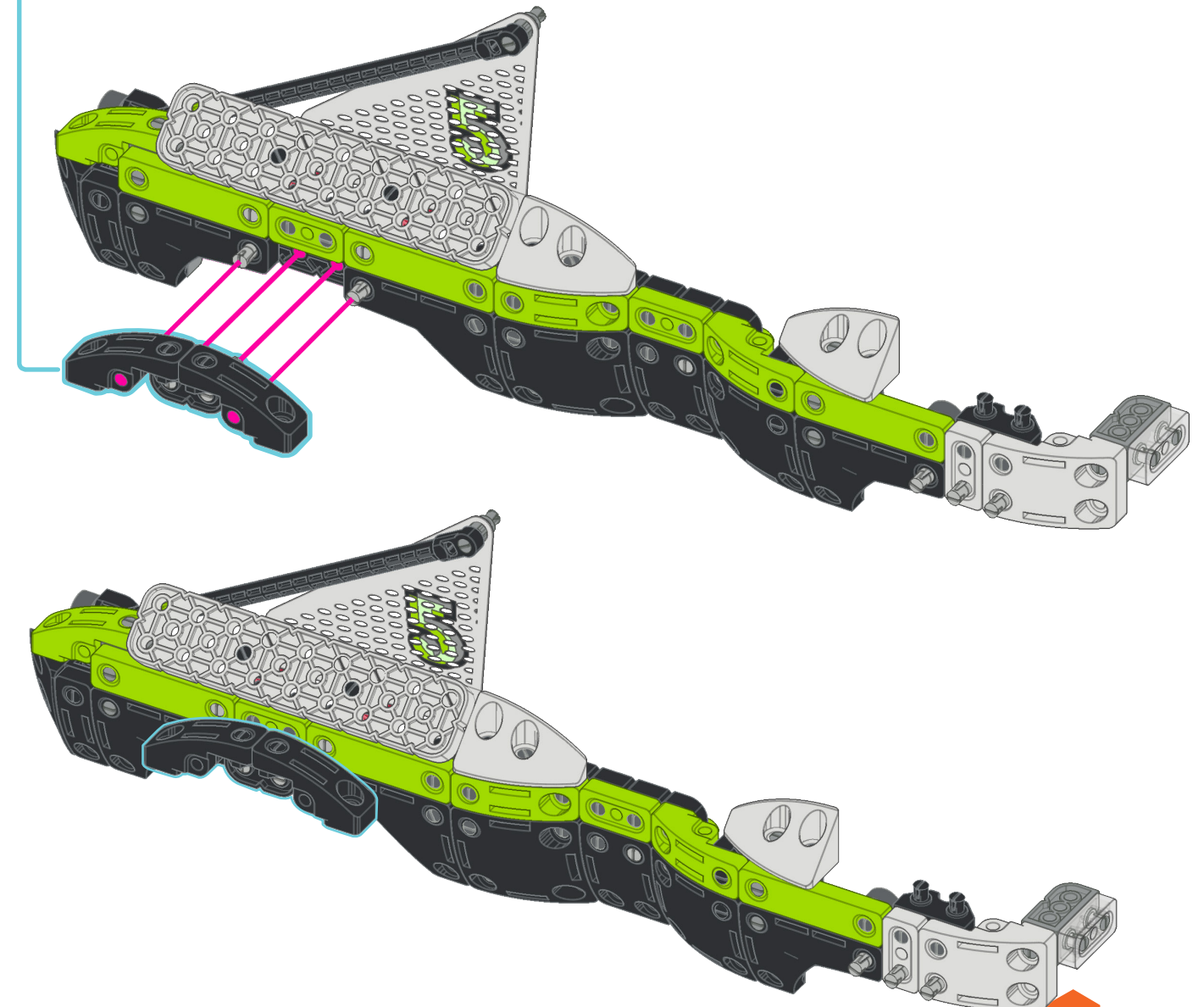
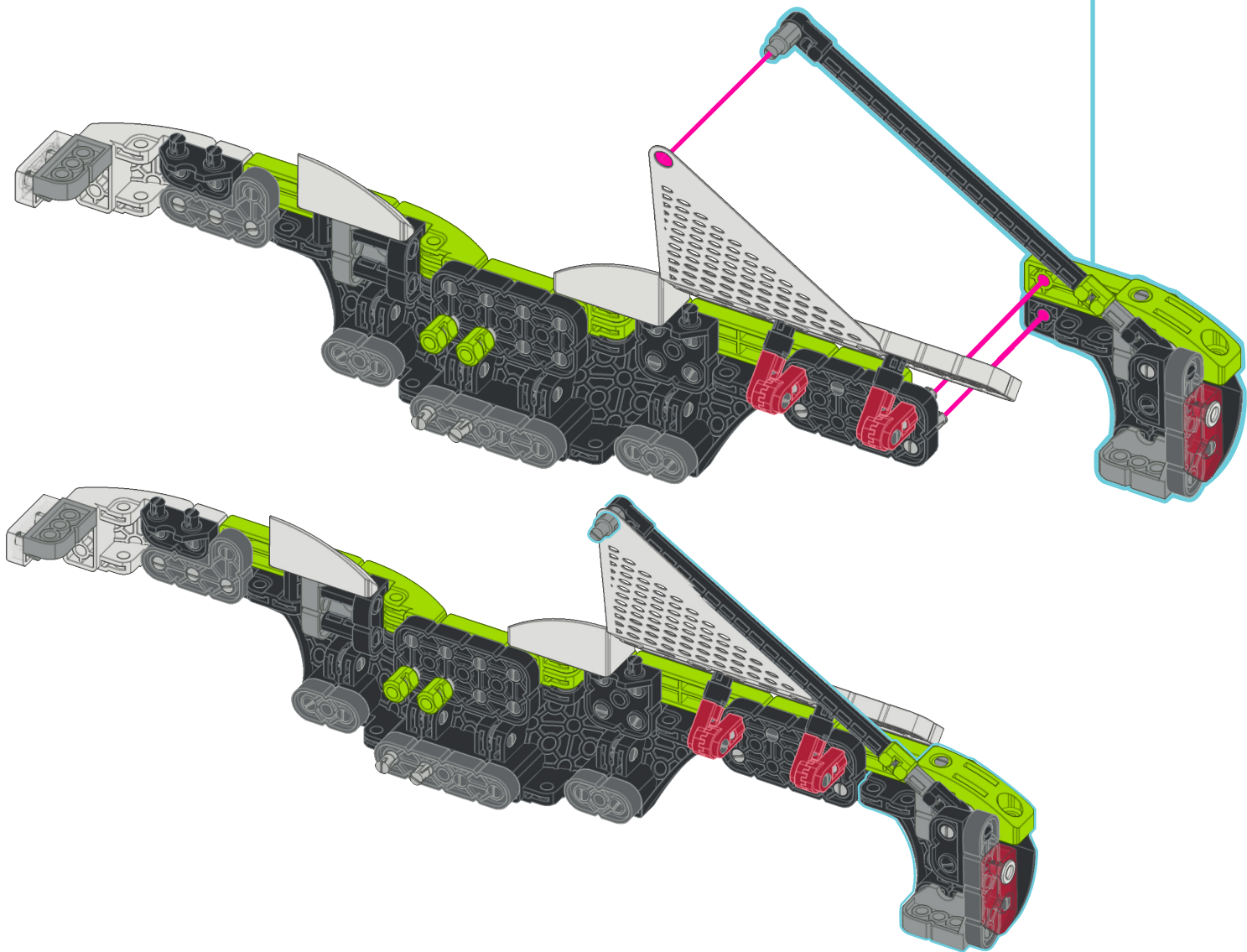
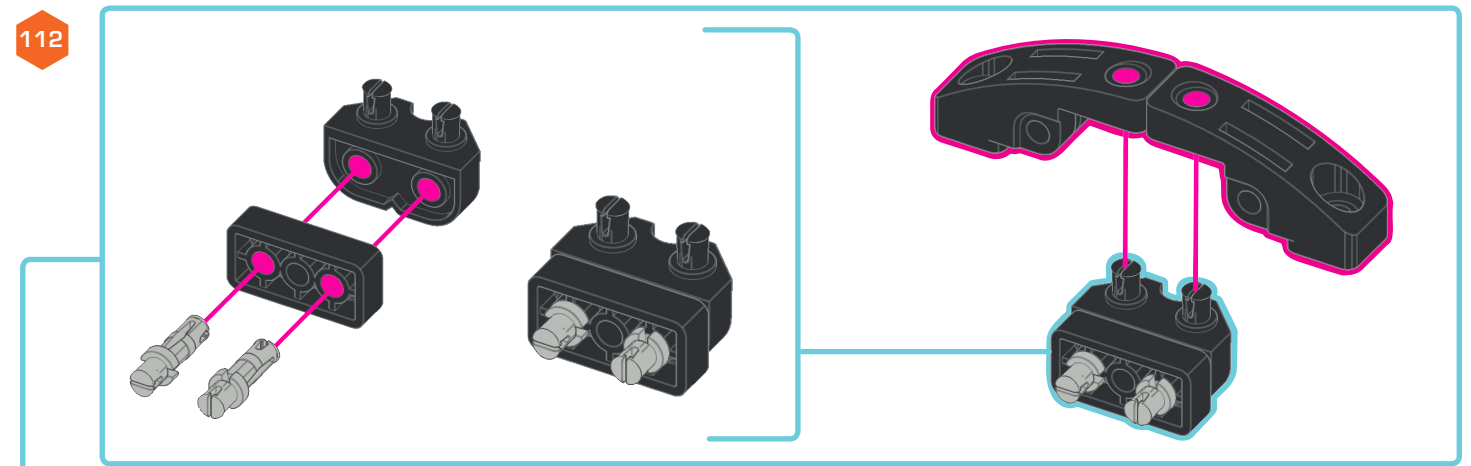

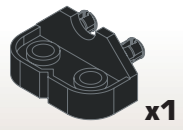

113



114

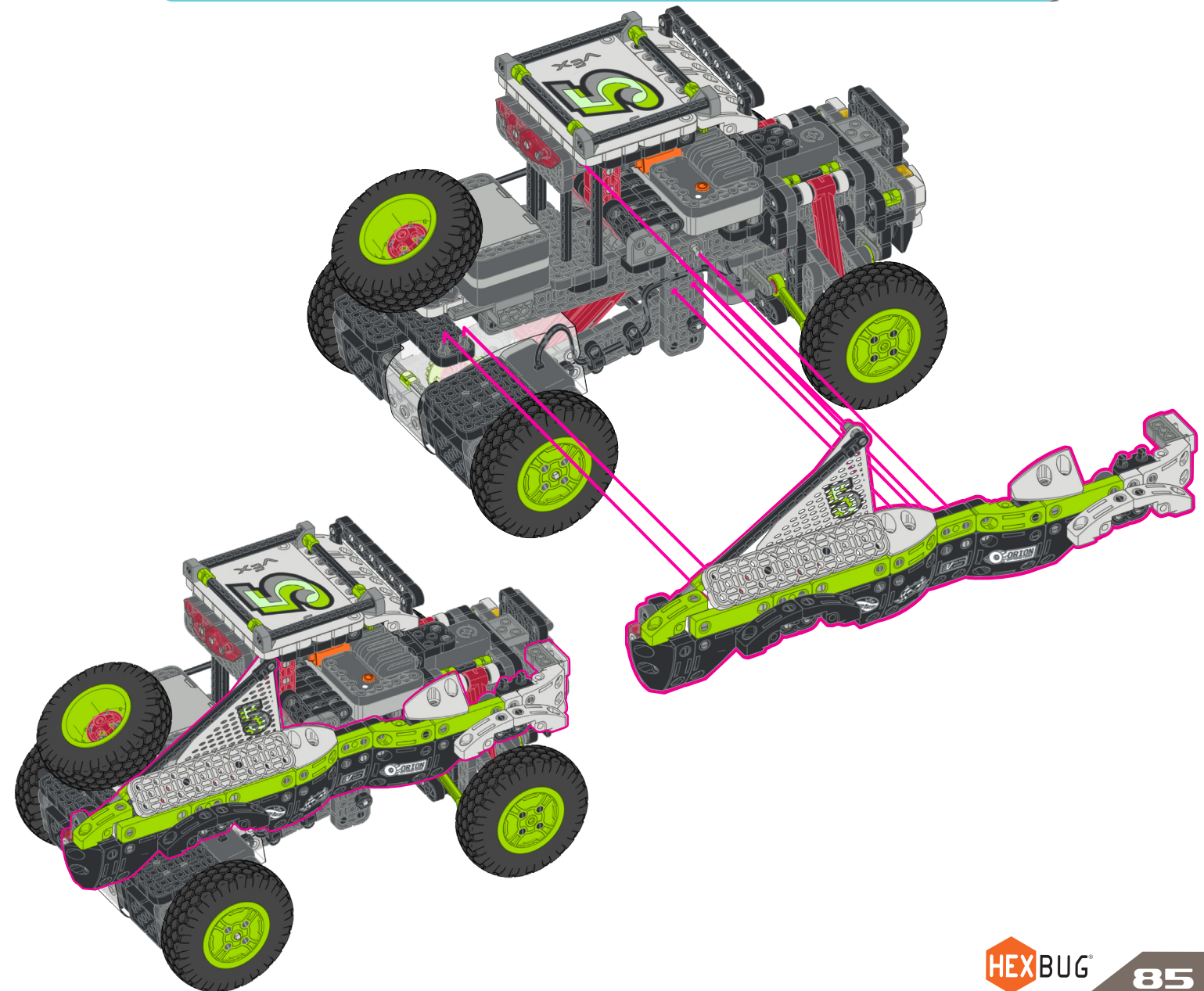
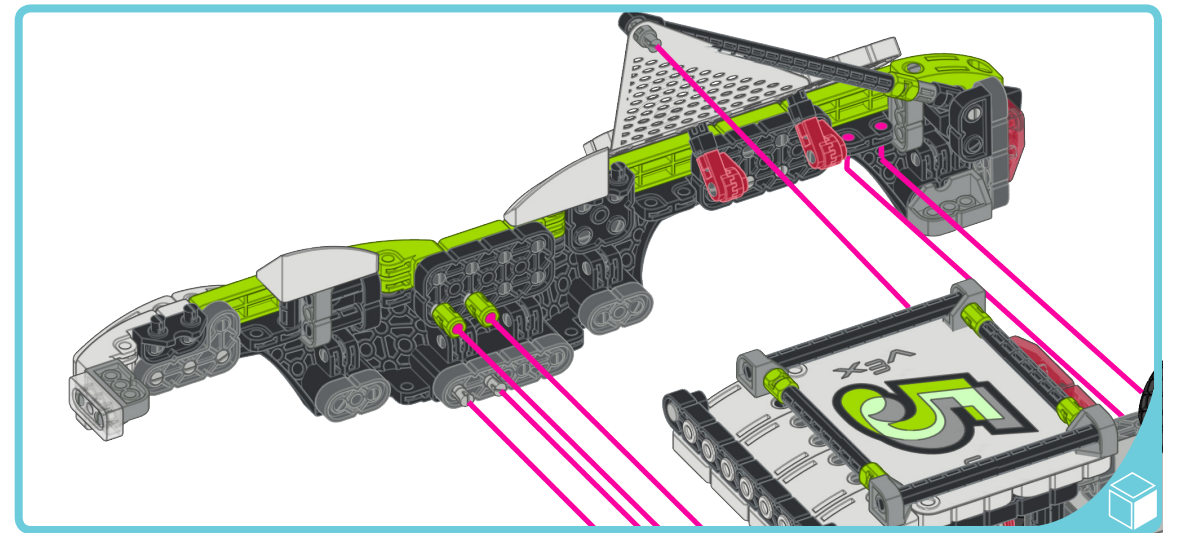

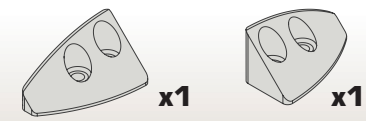
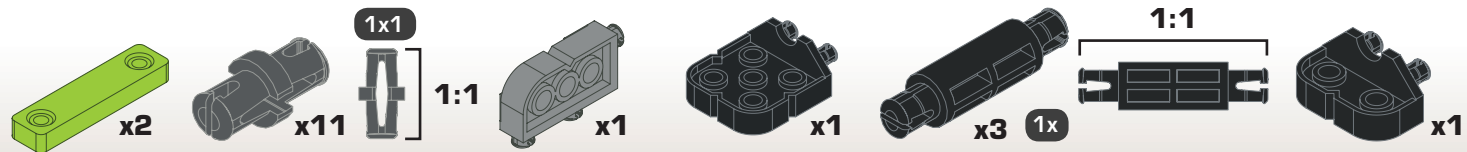

117

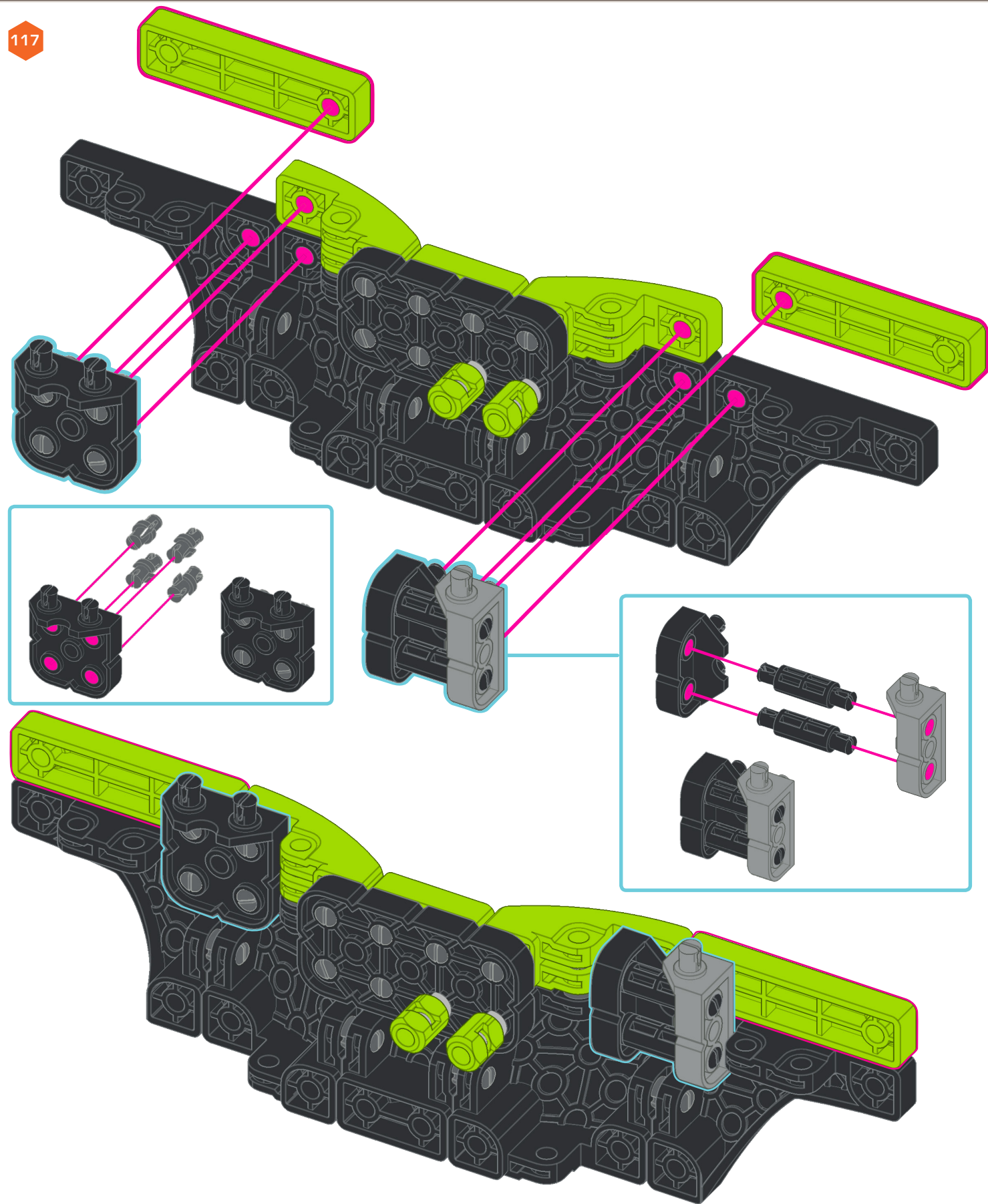

118

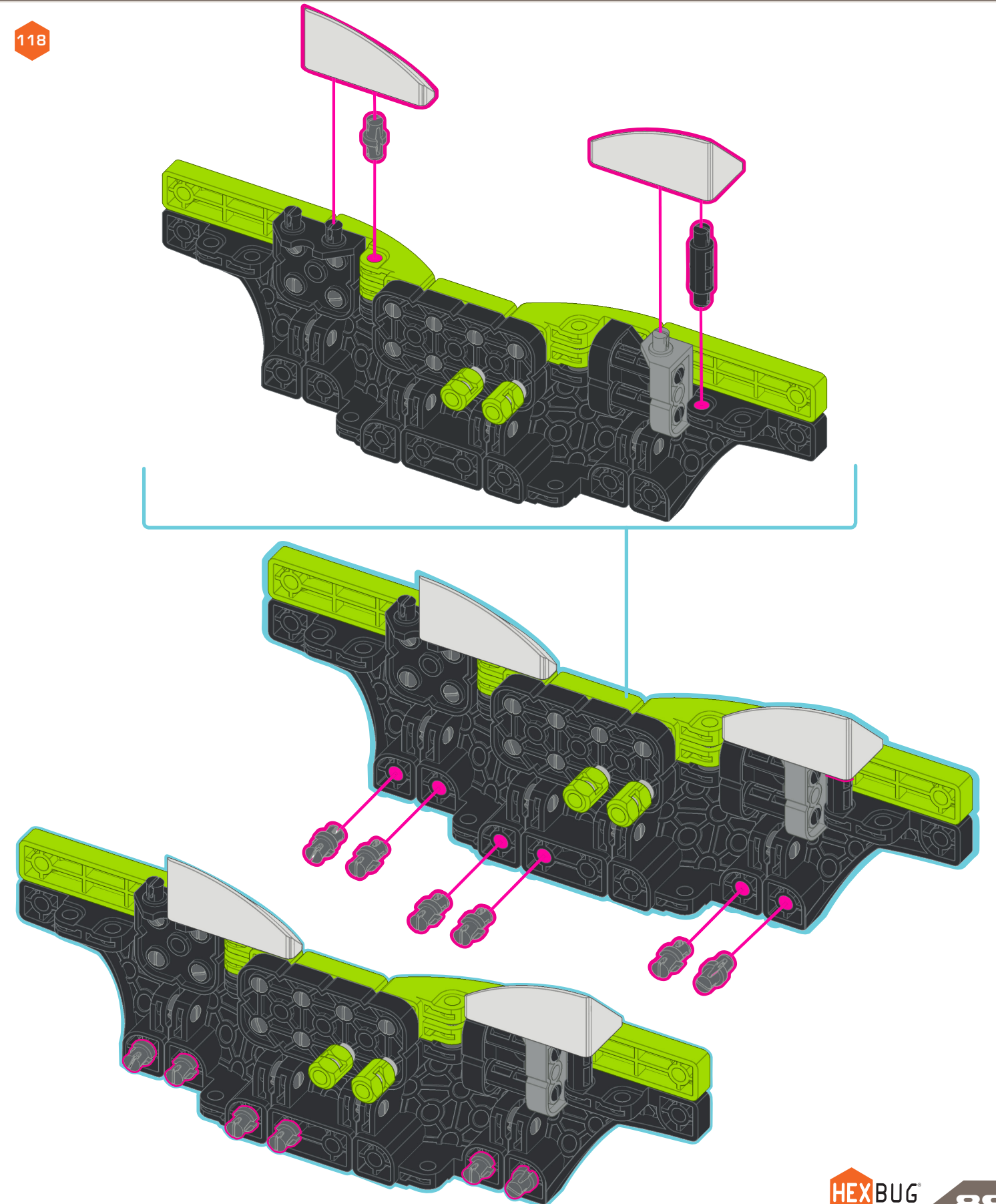

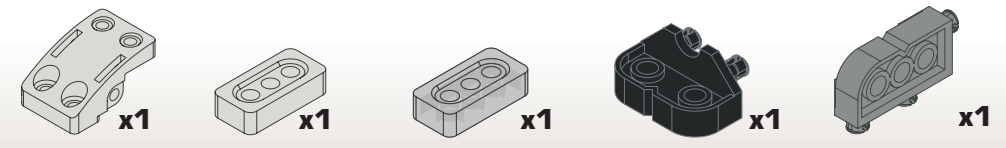
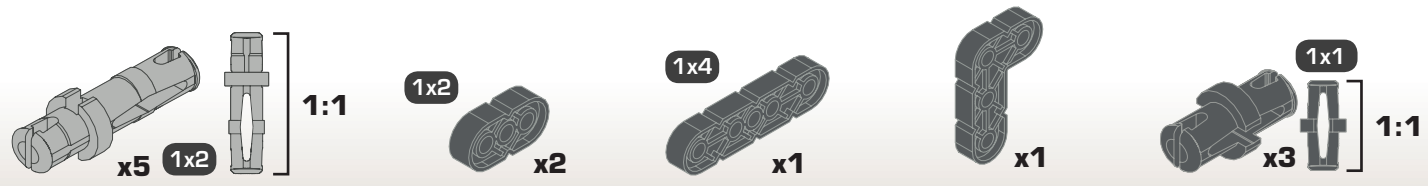

119

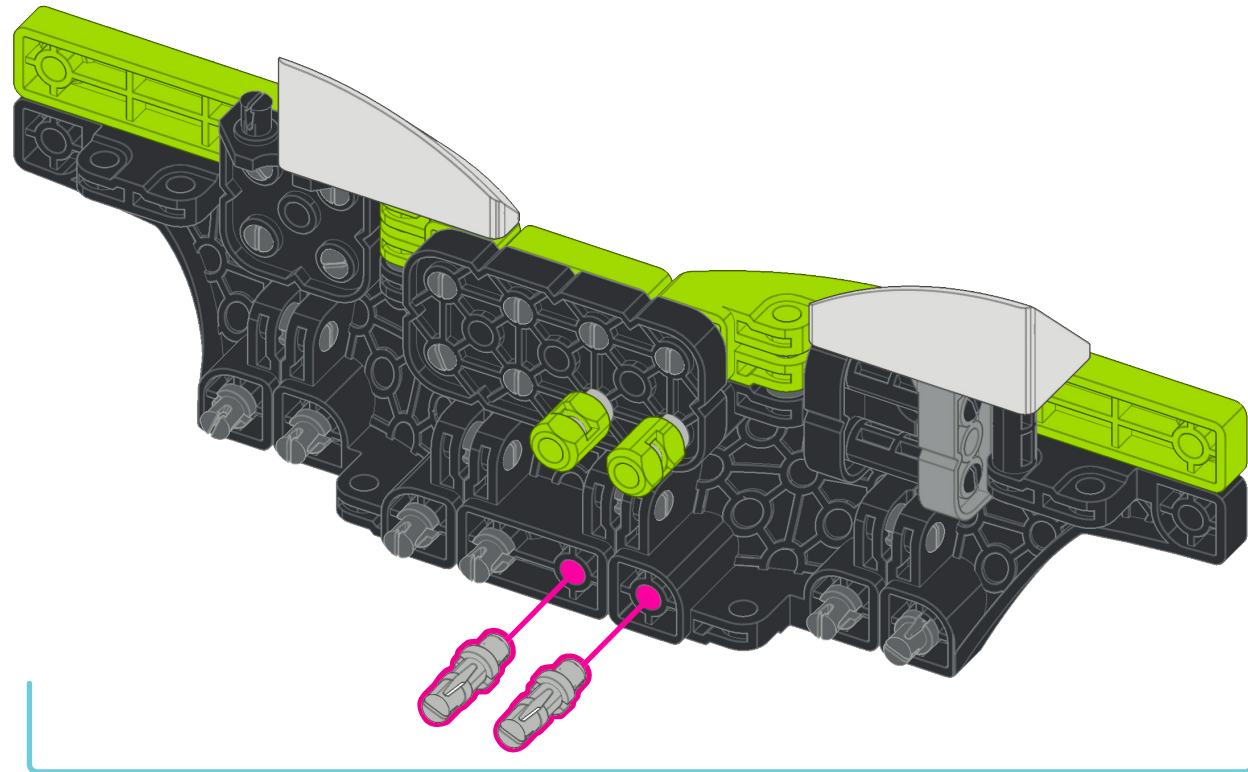

120

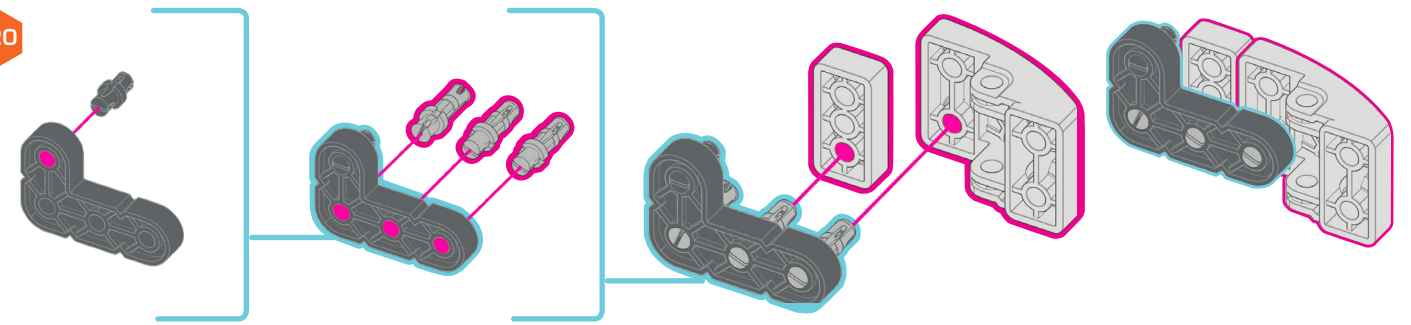

121

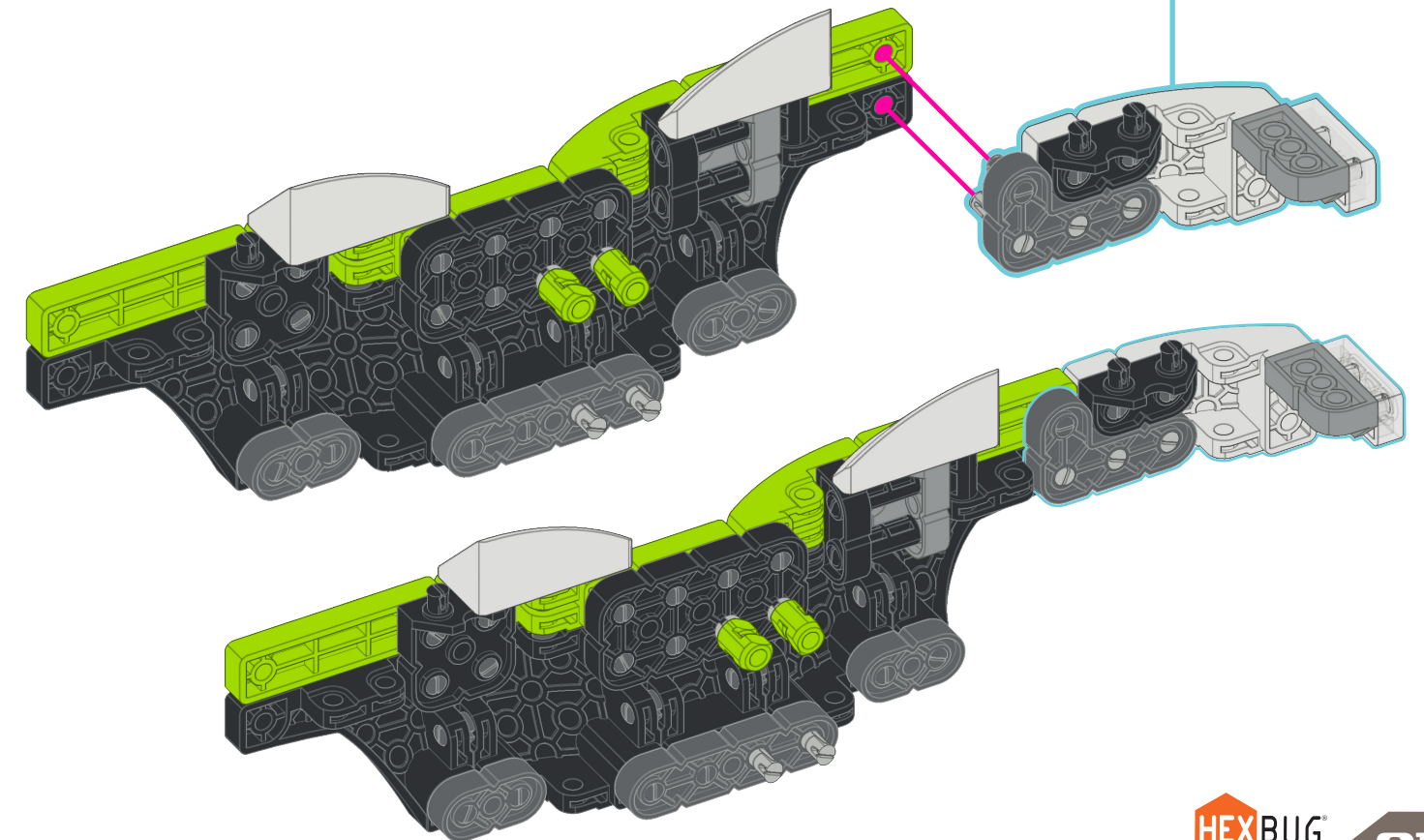
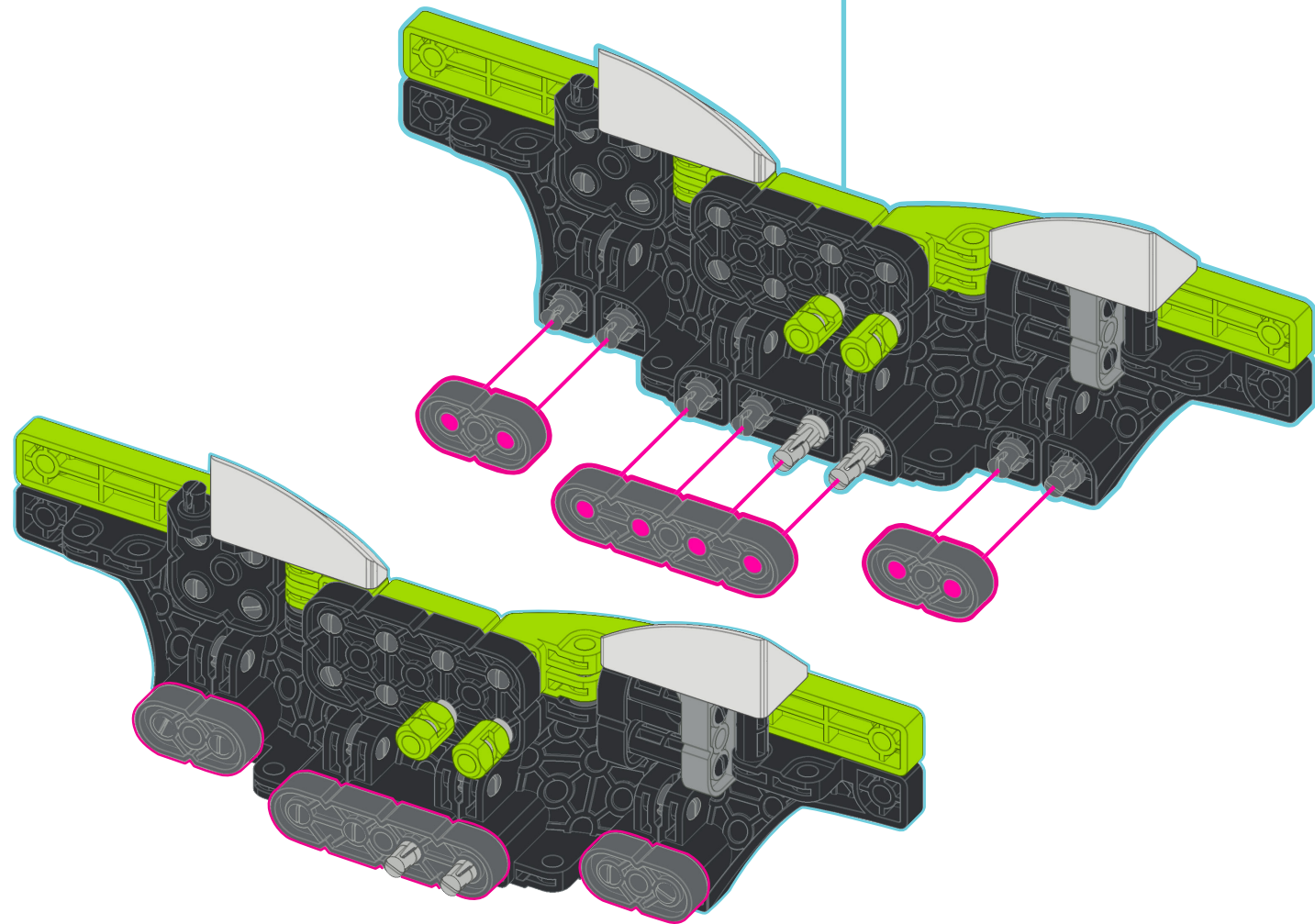
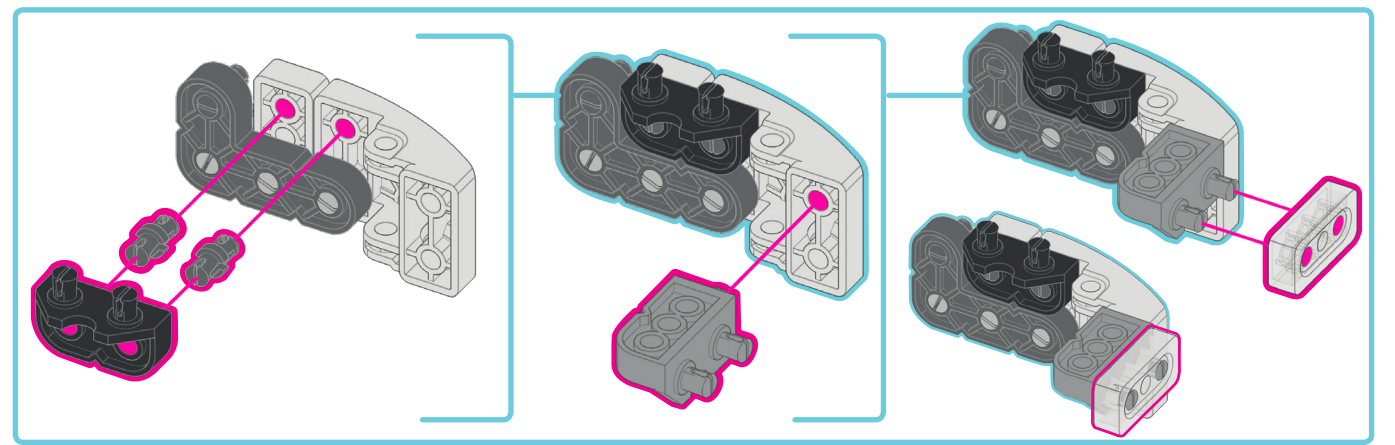

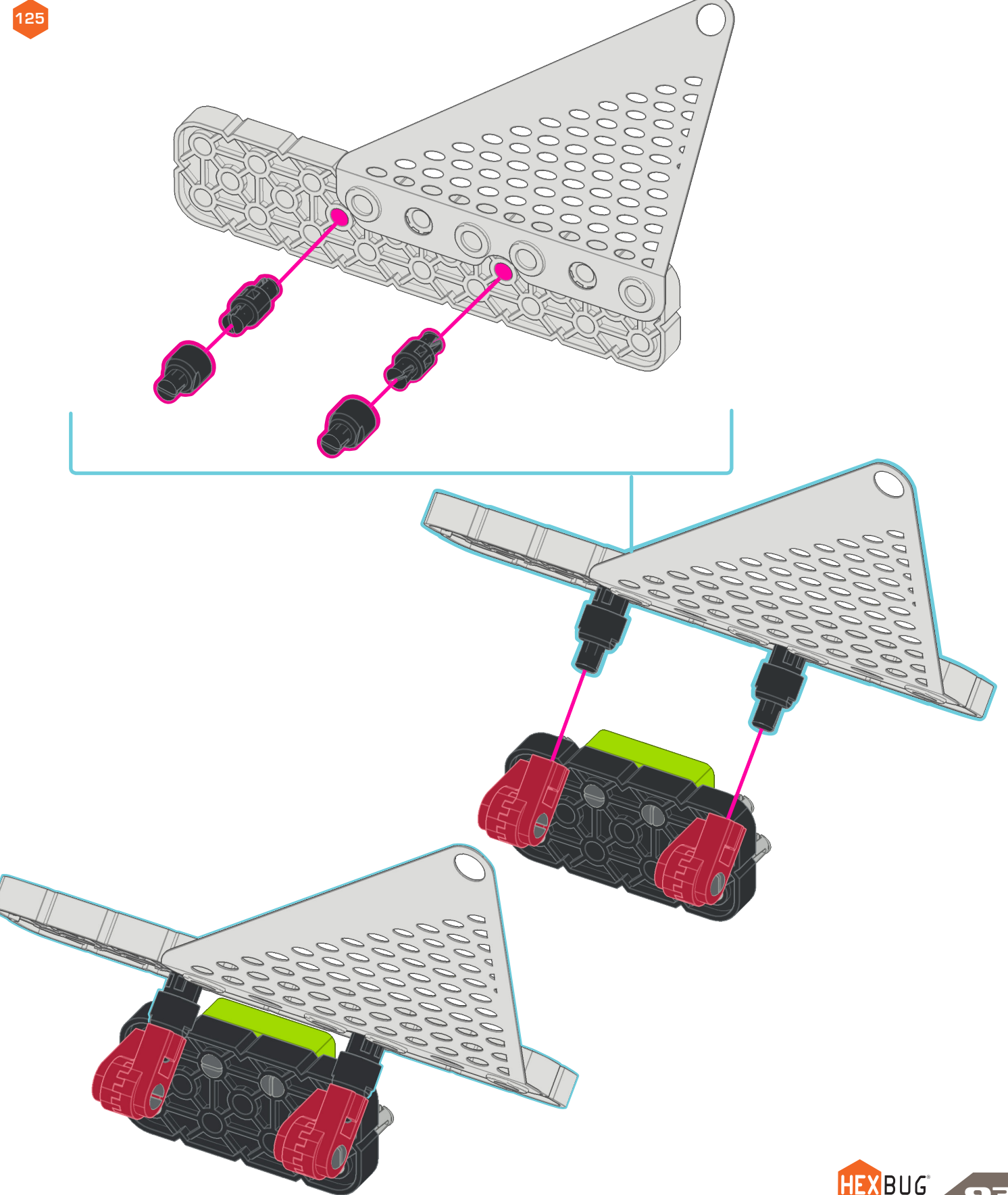
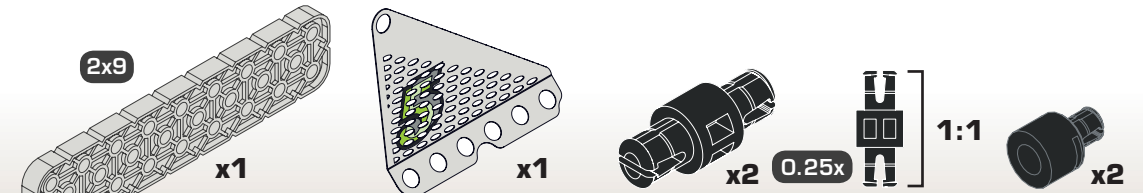
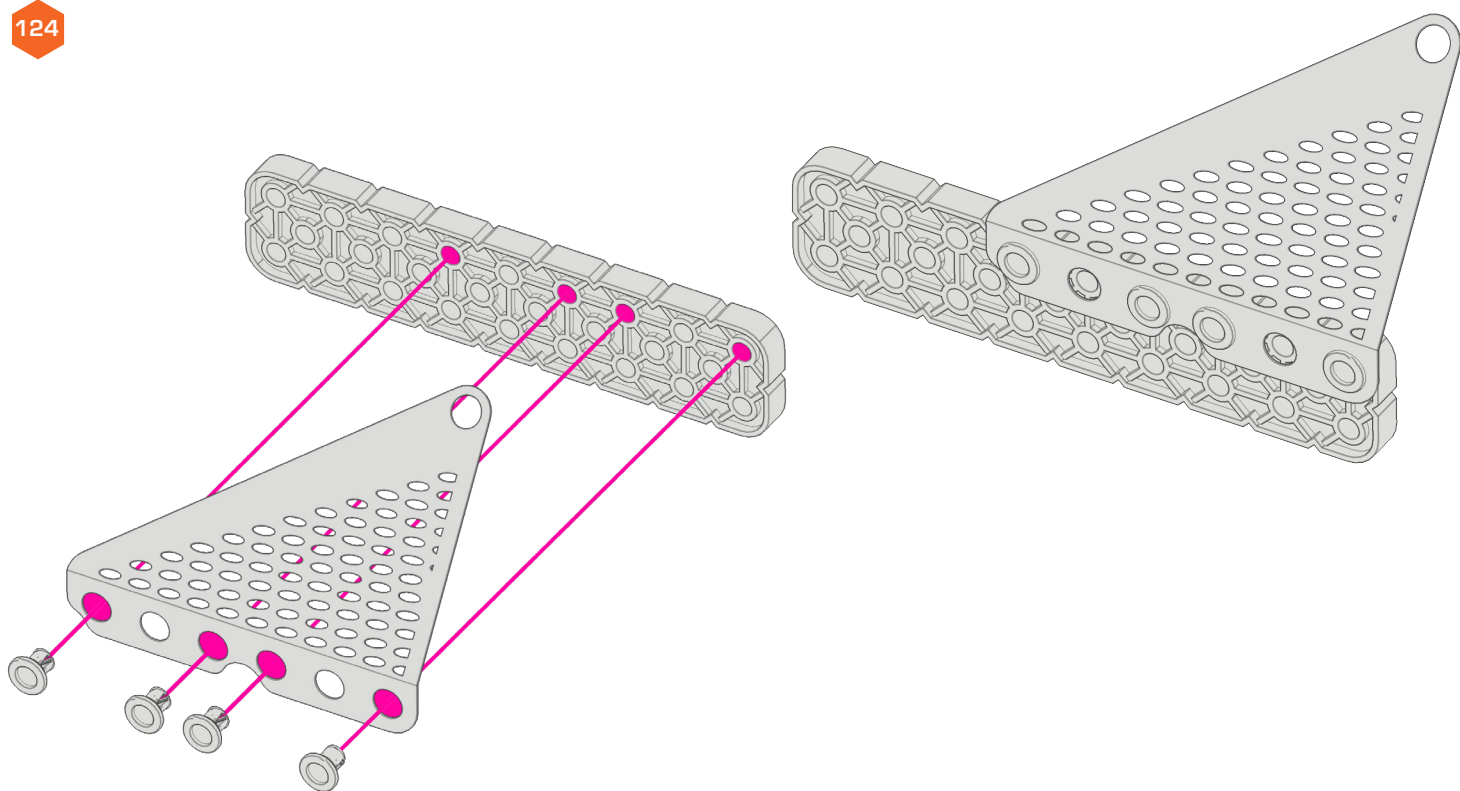
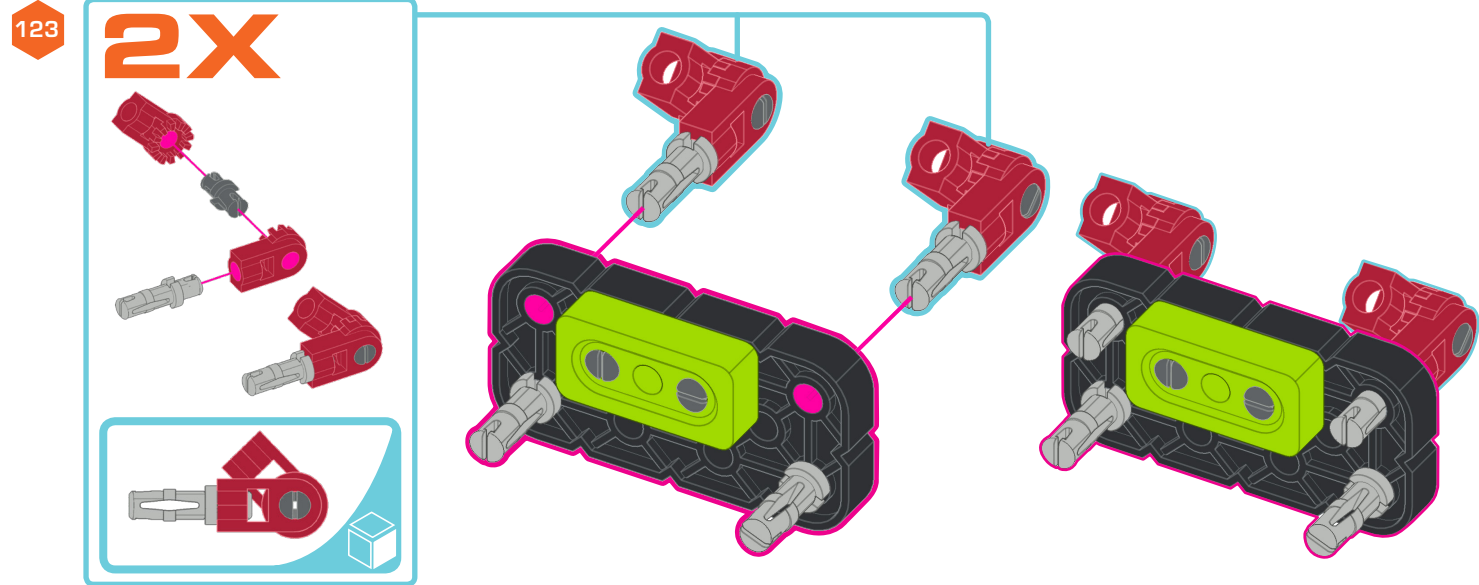
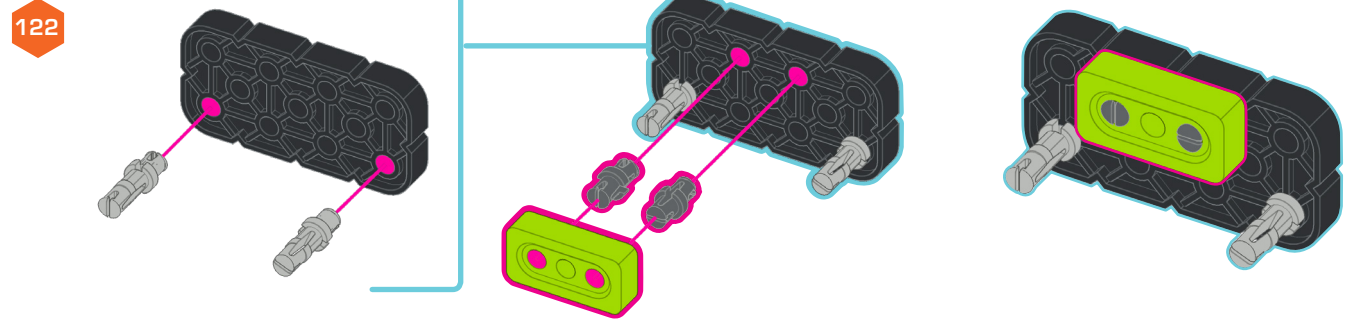
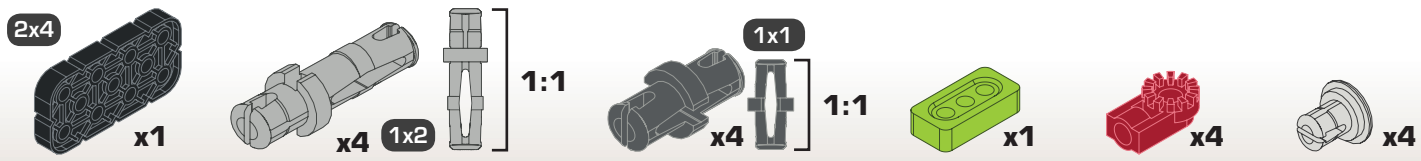

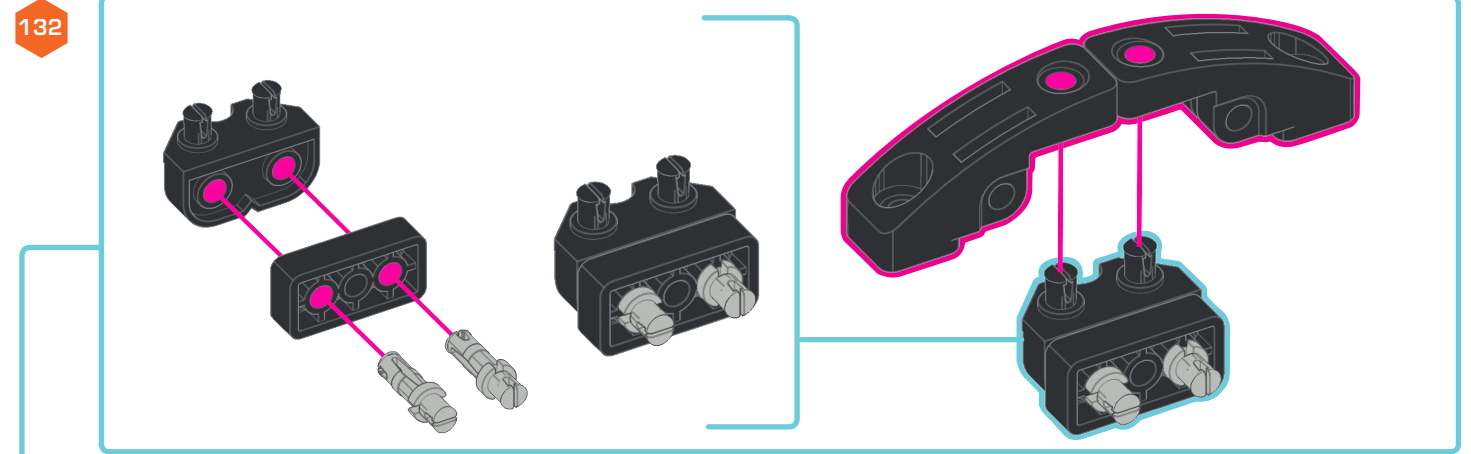
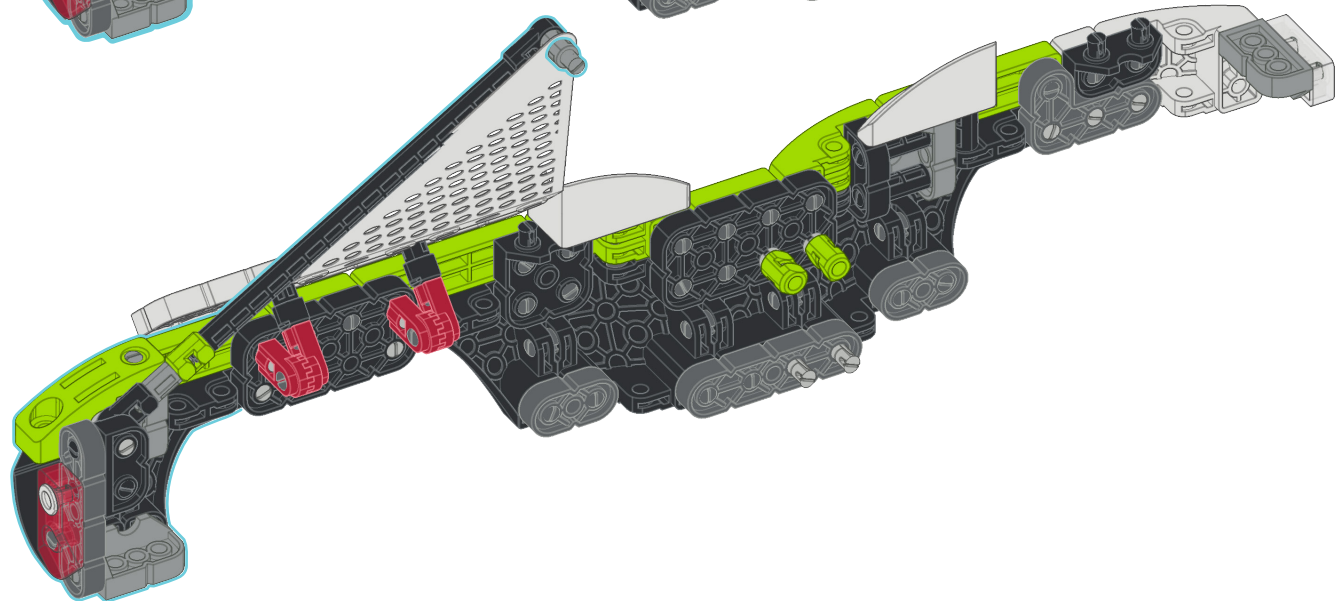
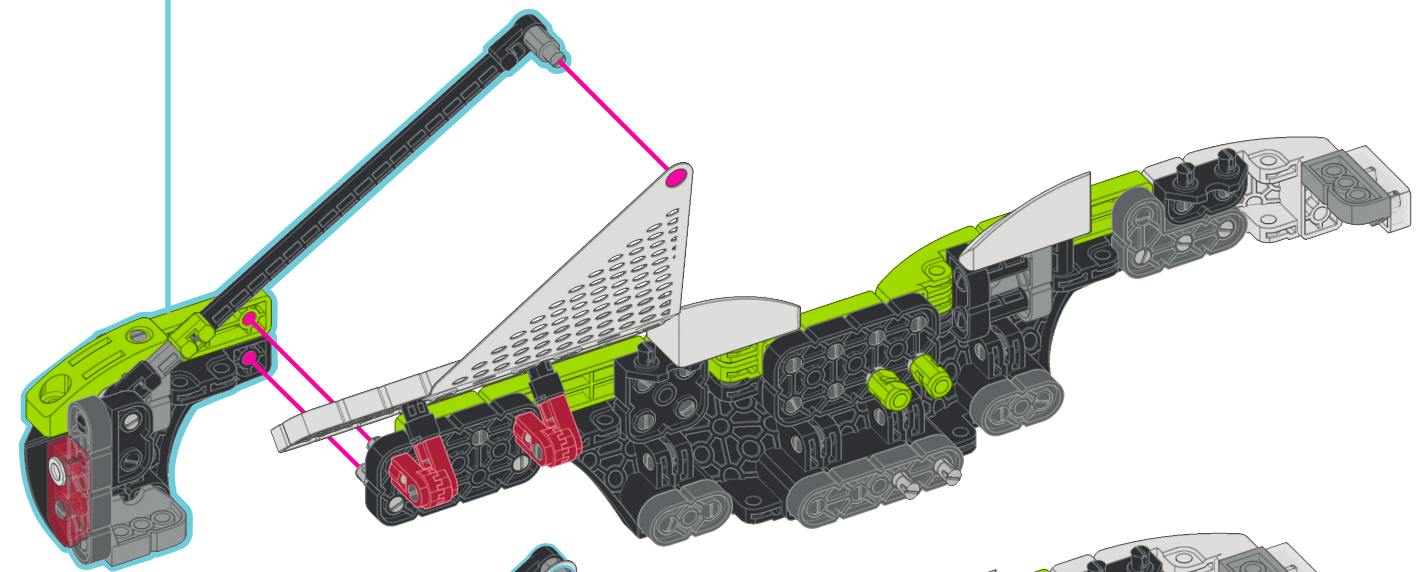
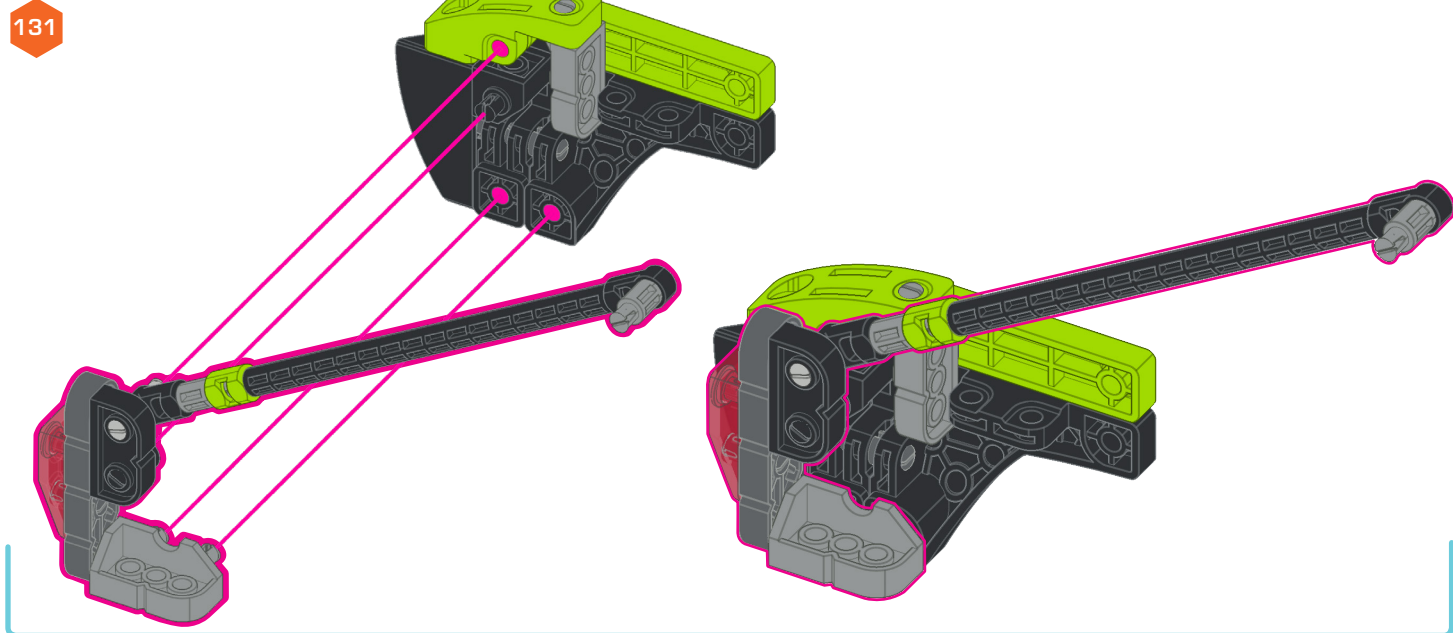
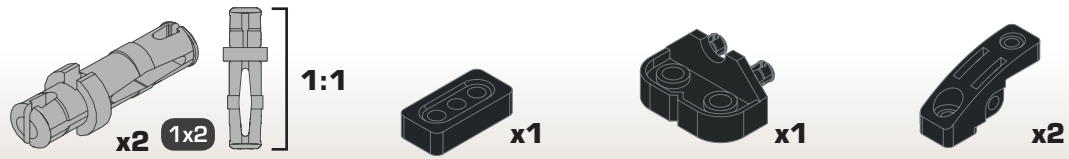

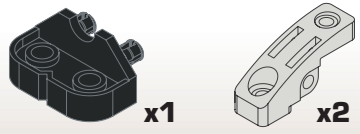

133

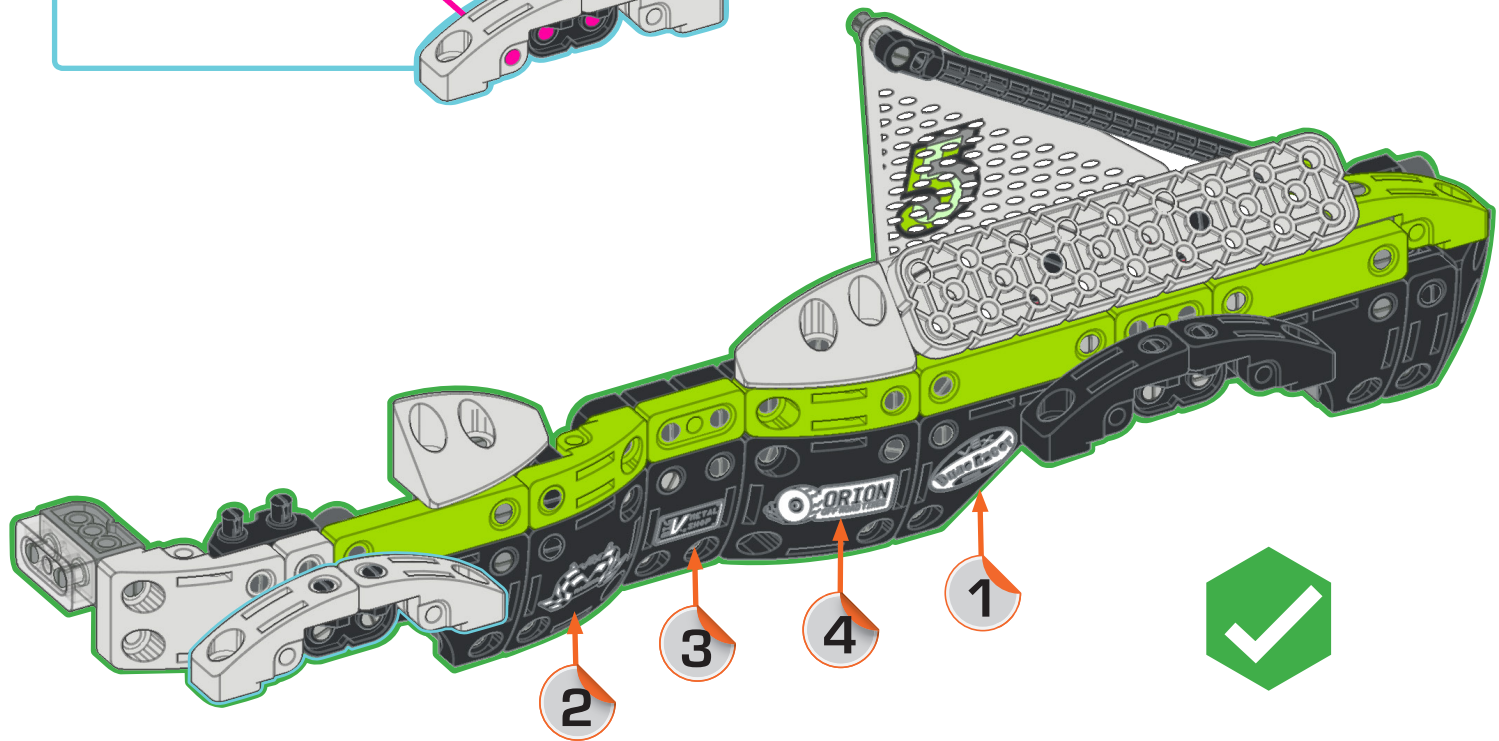
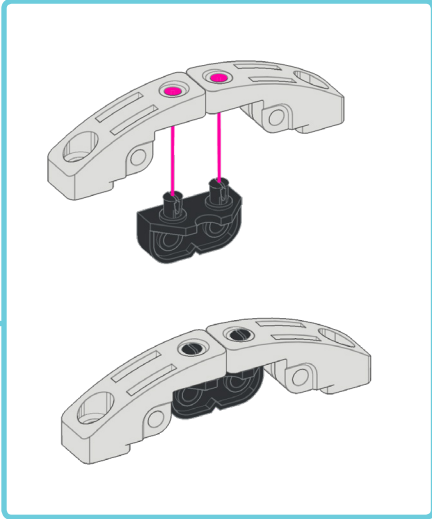

134

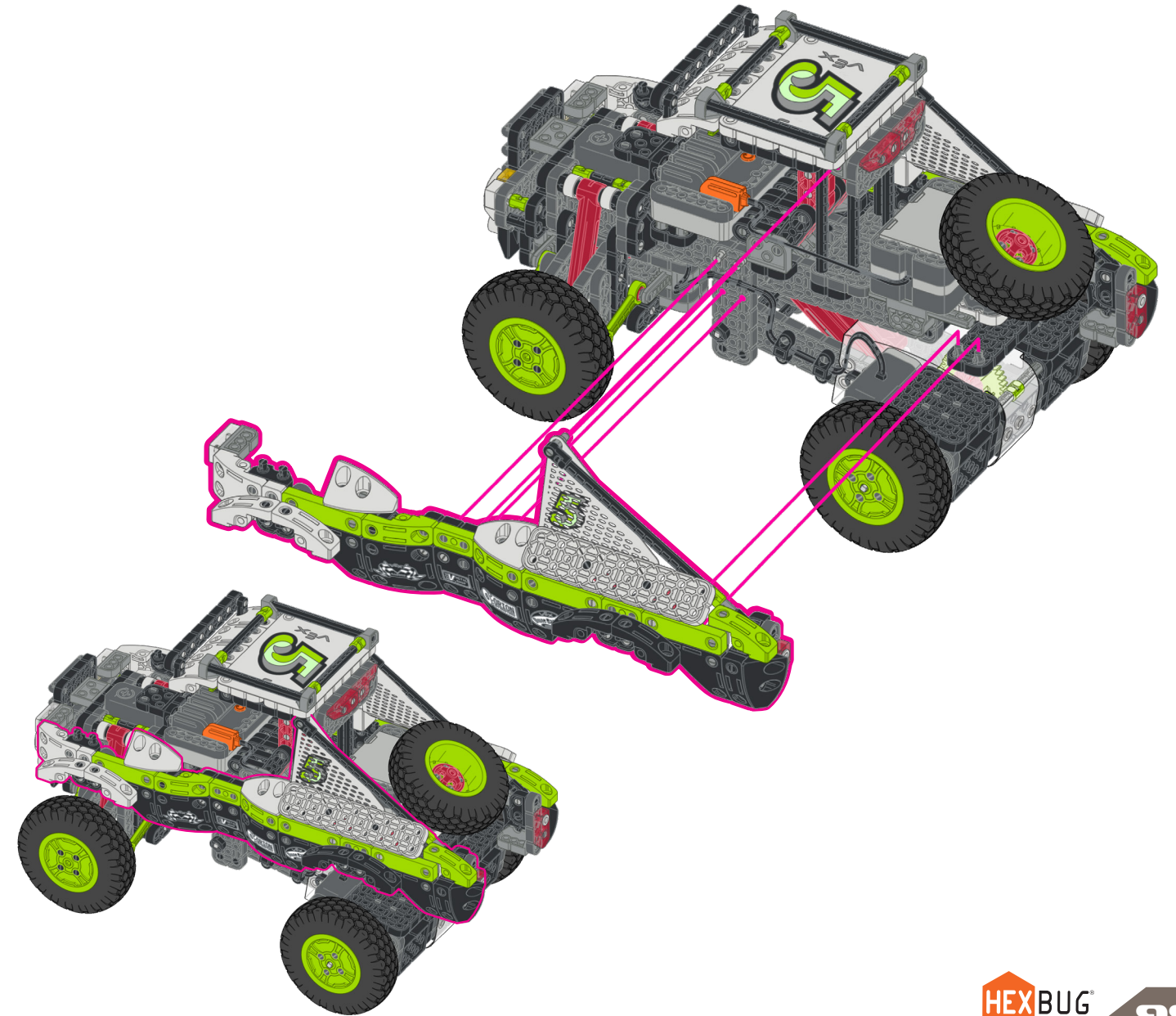
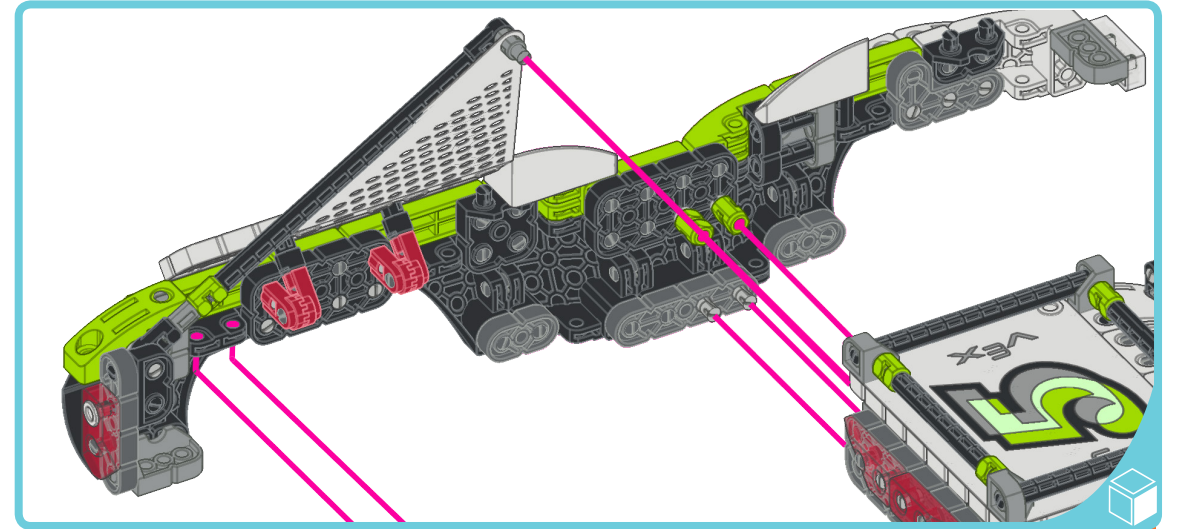

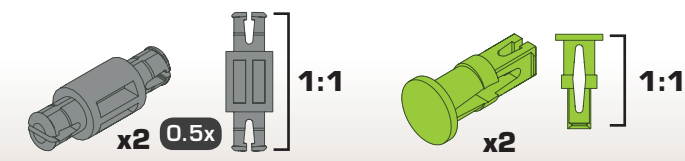
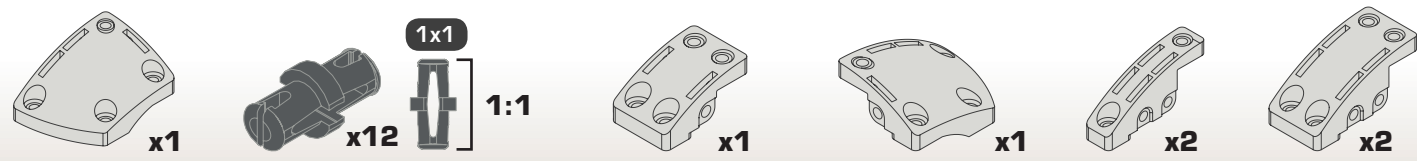

135

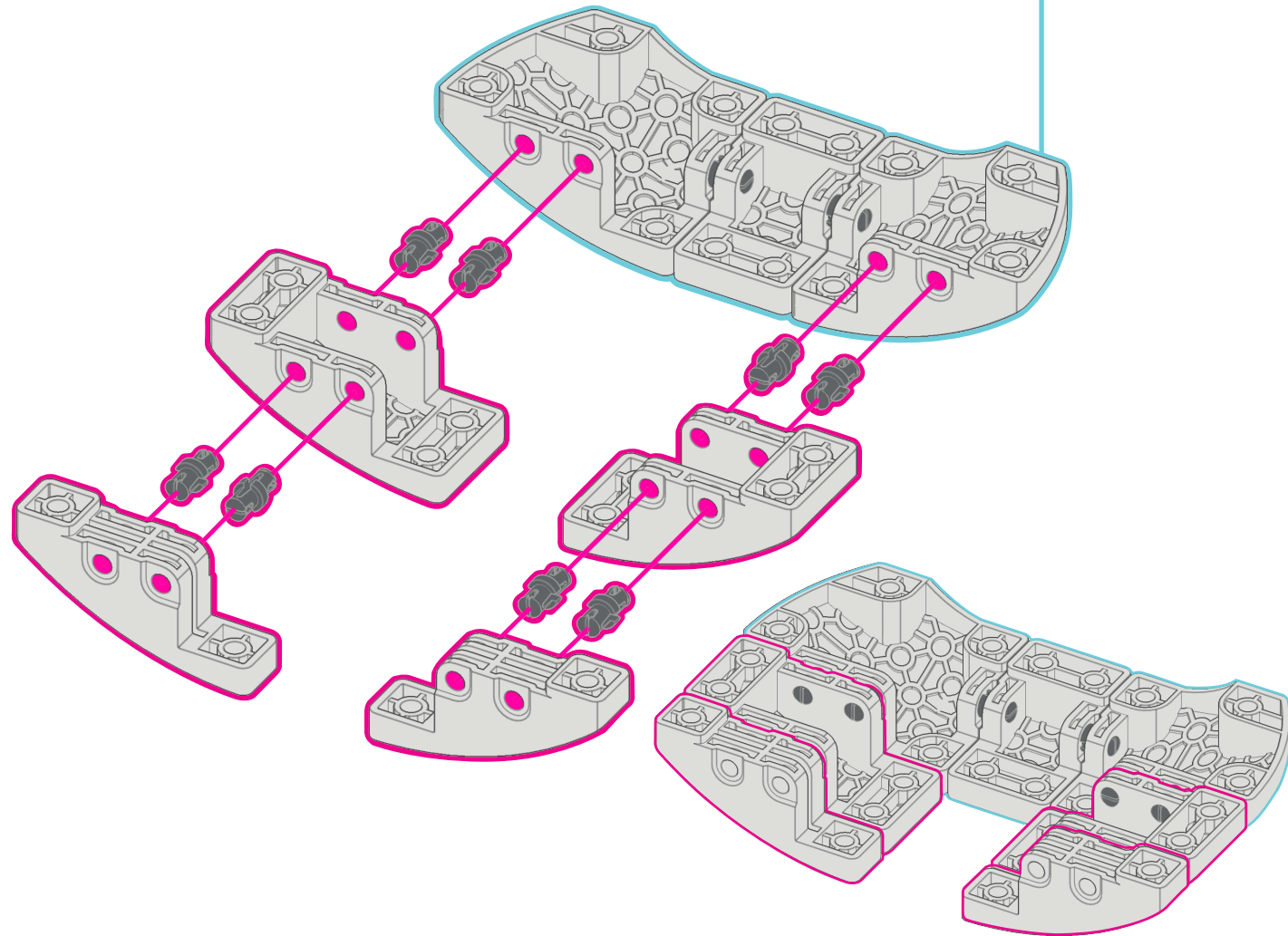
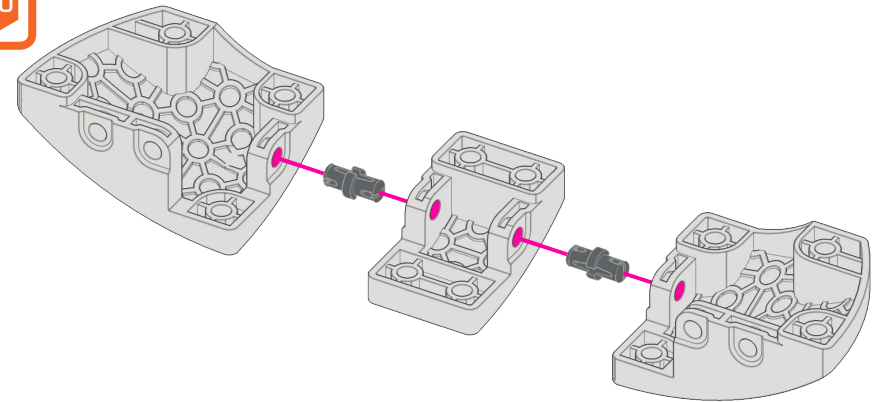
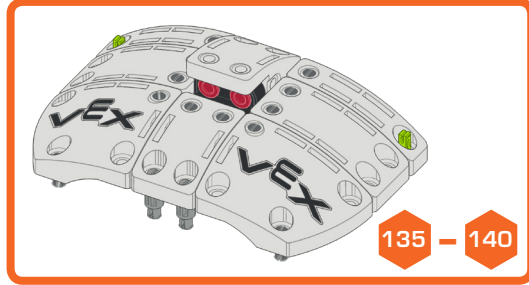

136

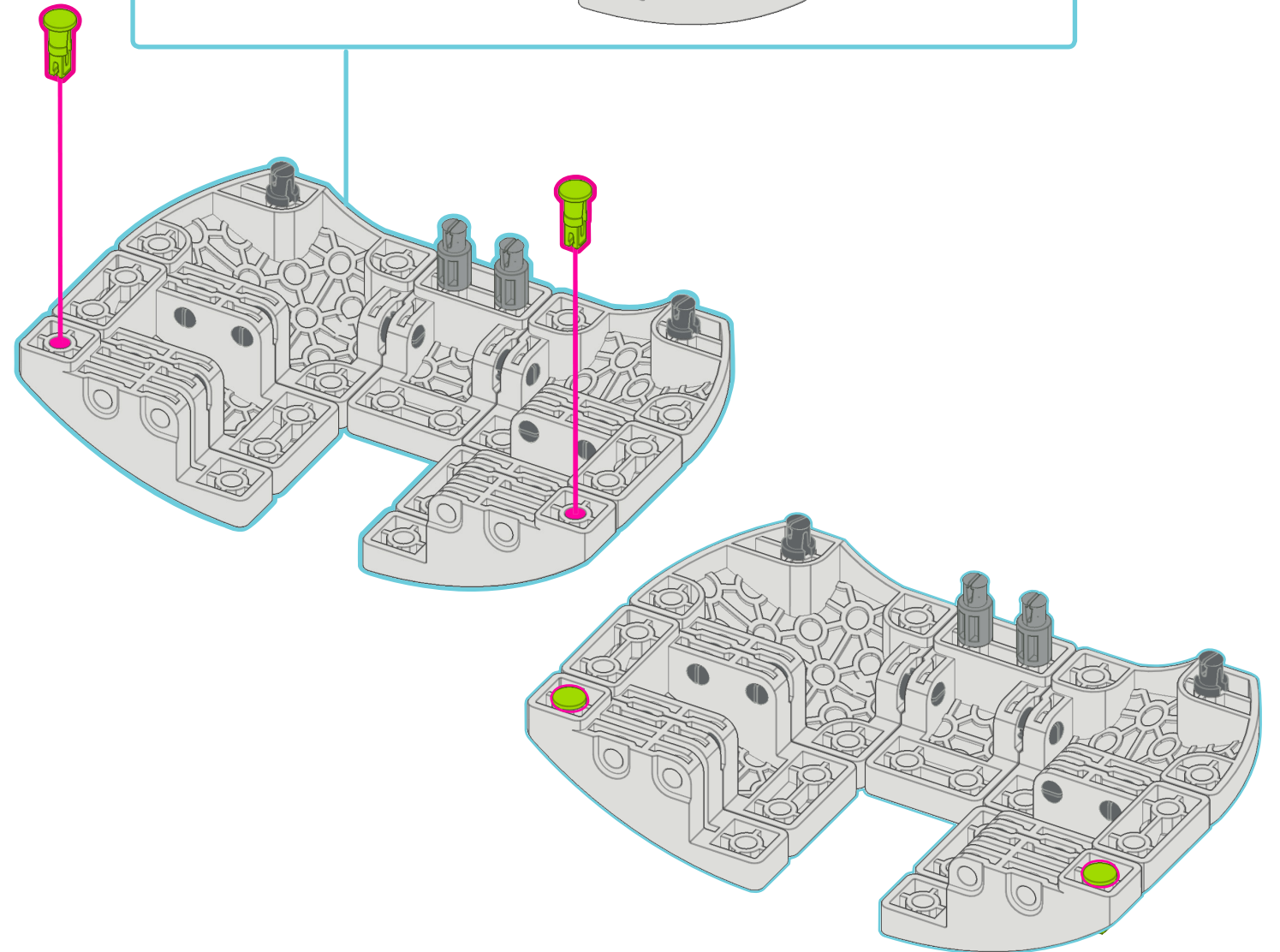
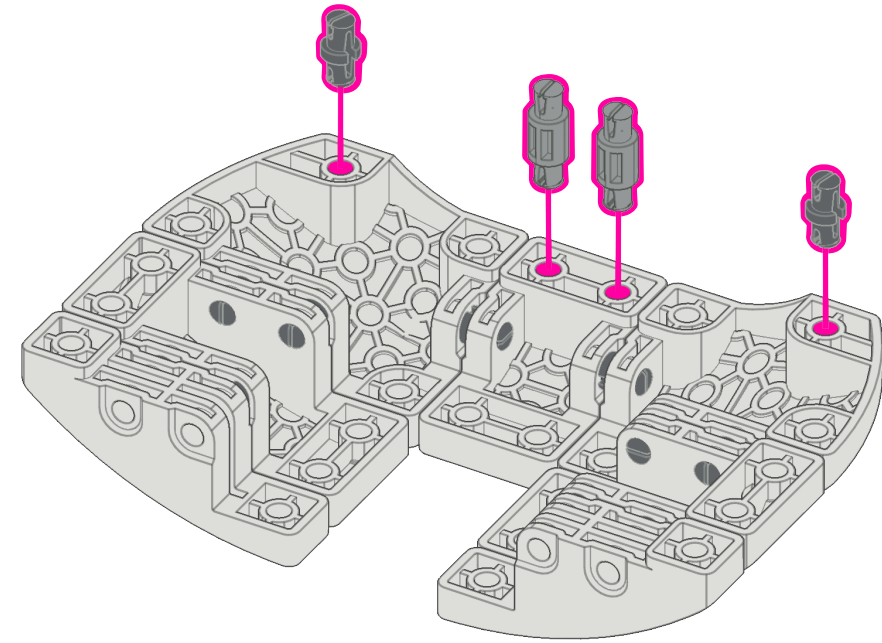

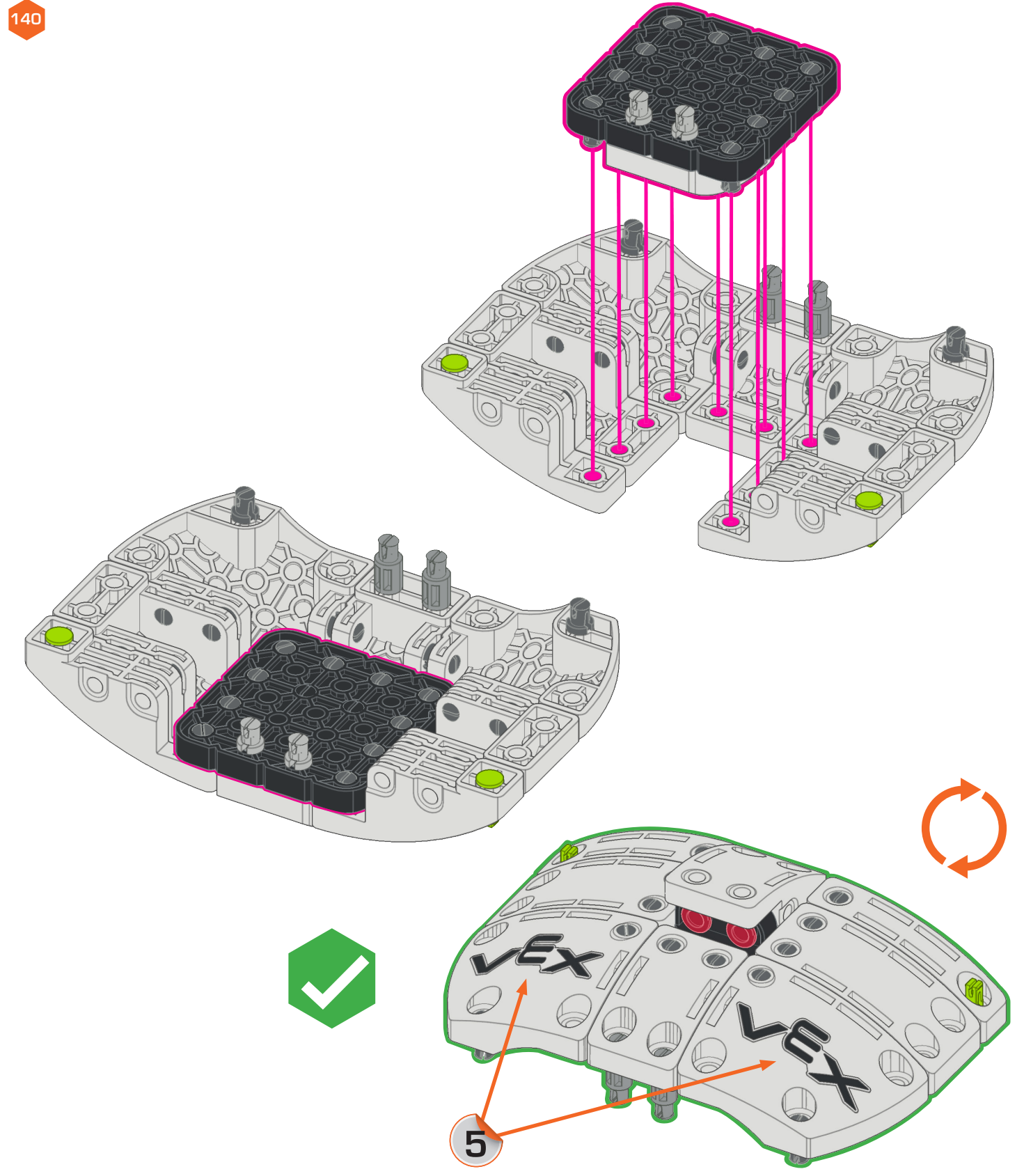
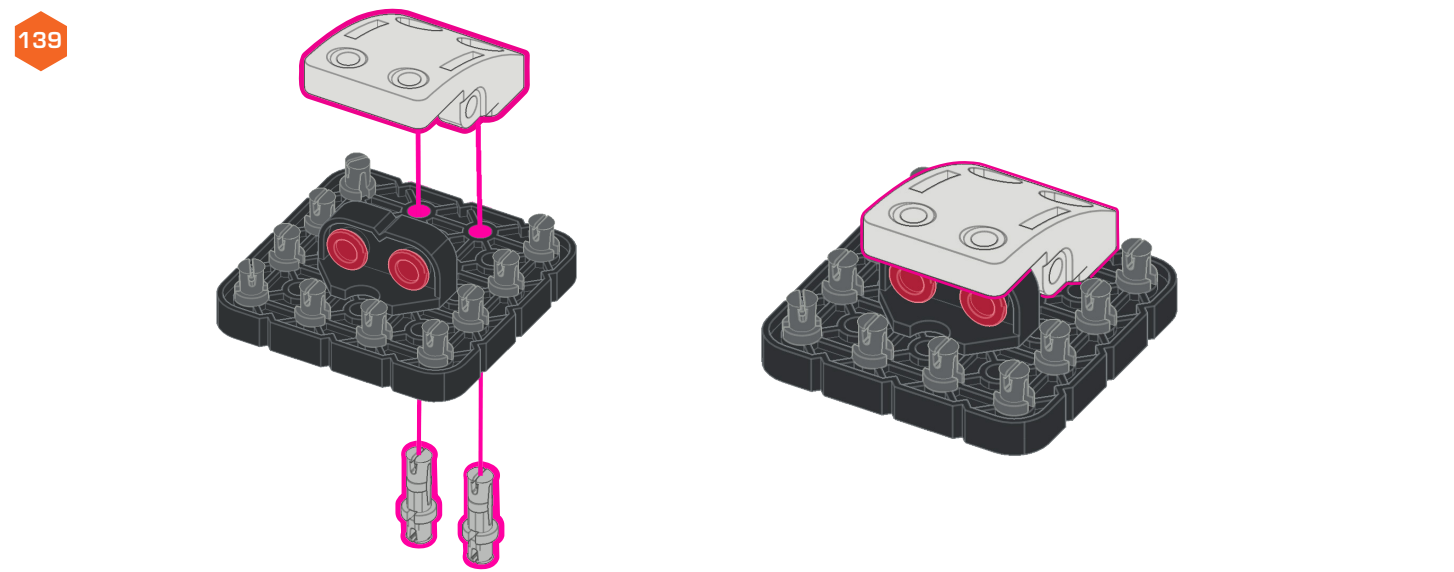
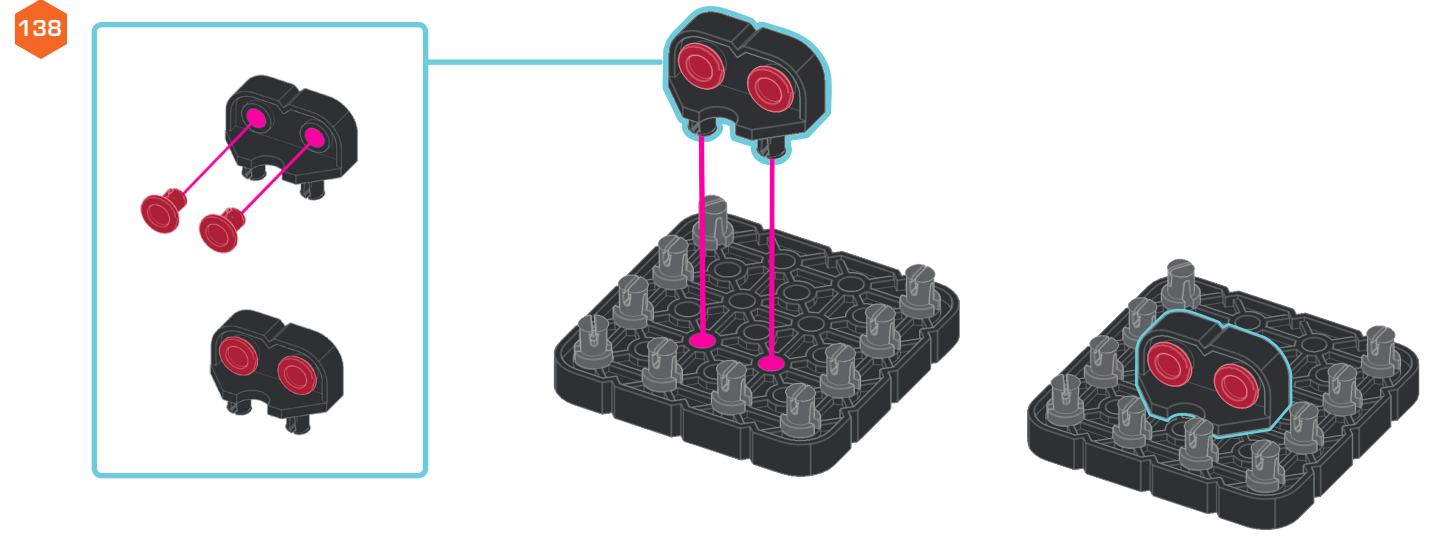
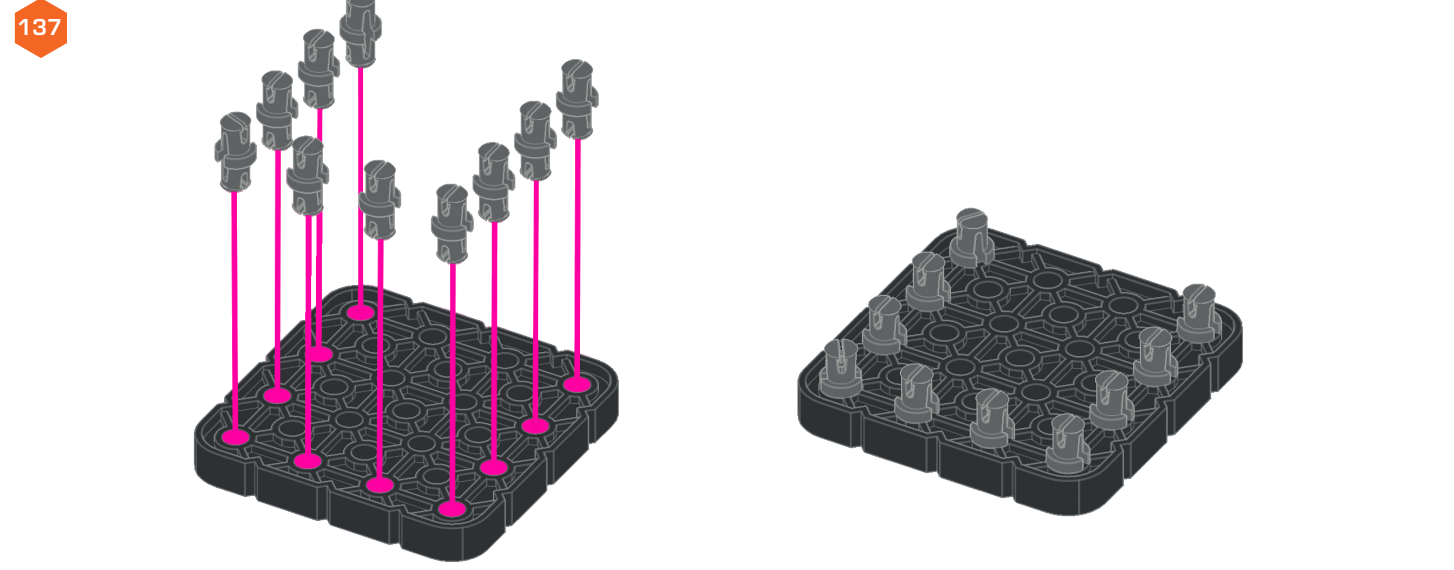
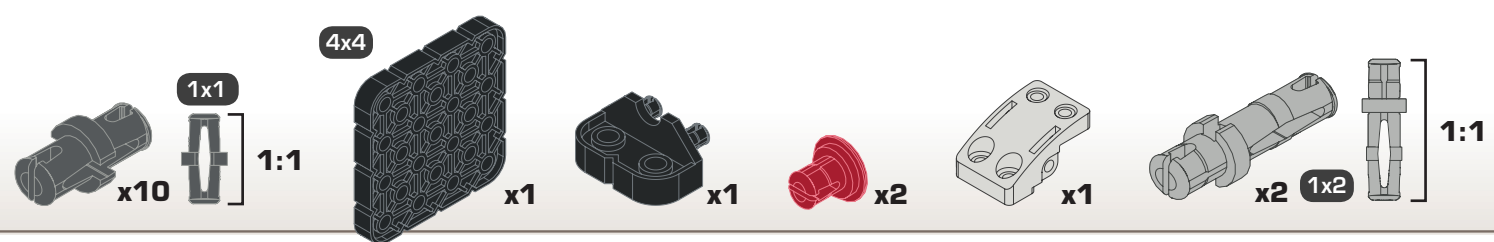

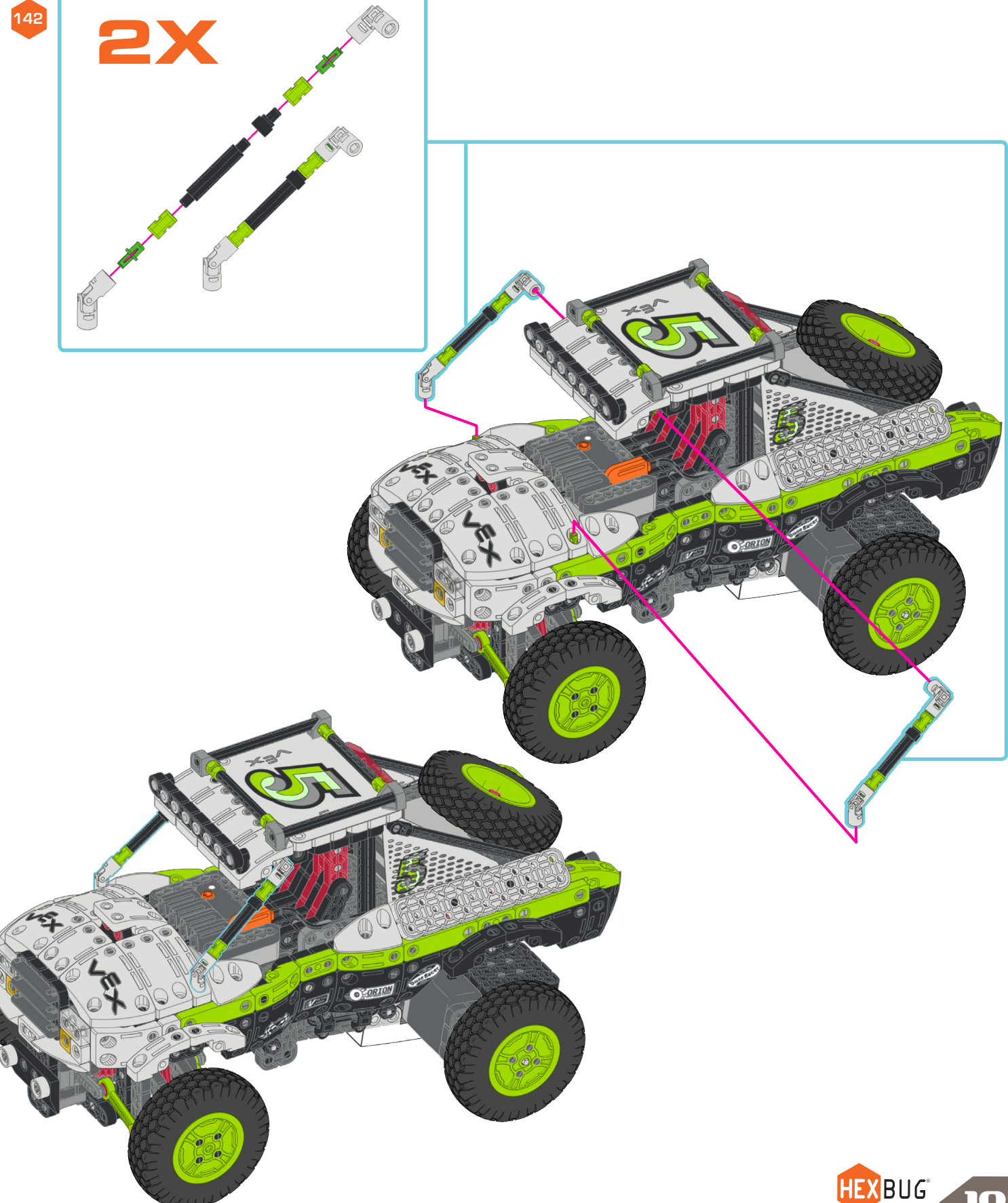
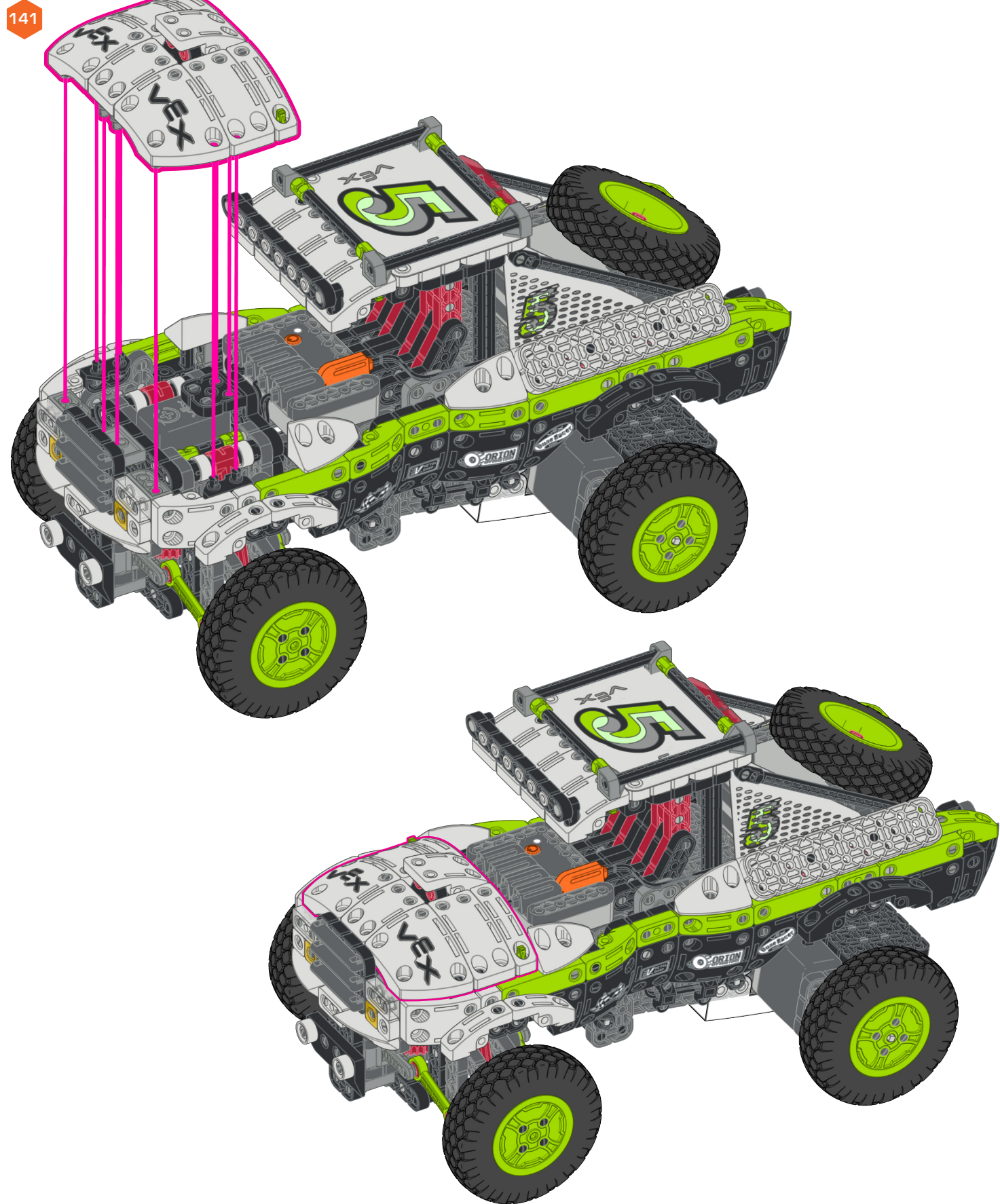

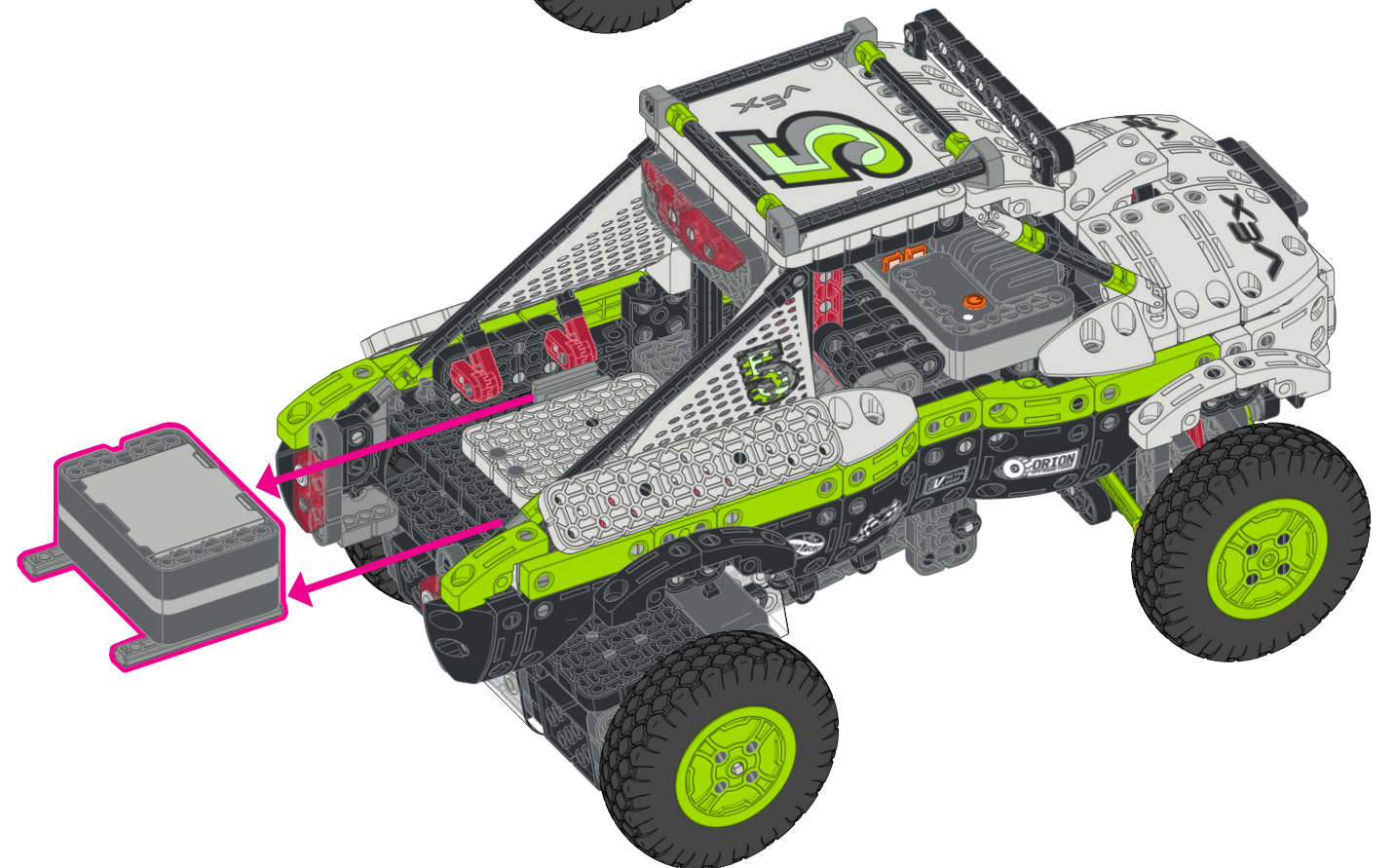
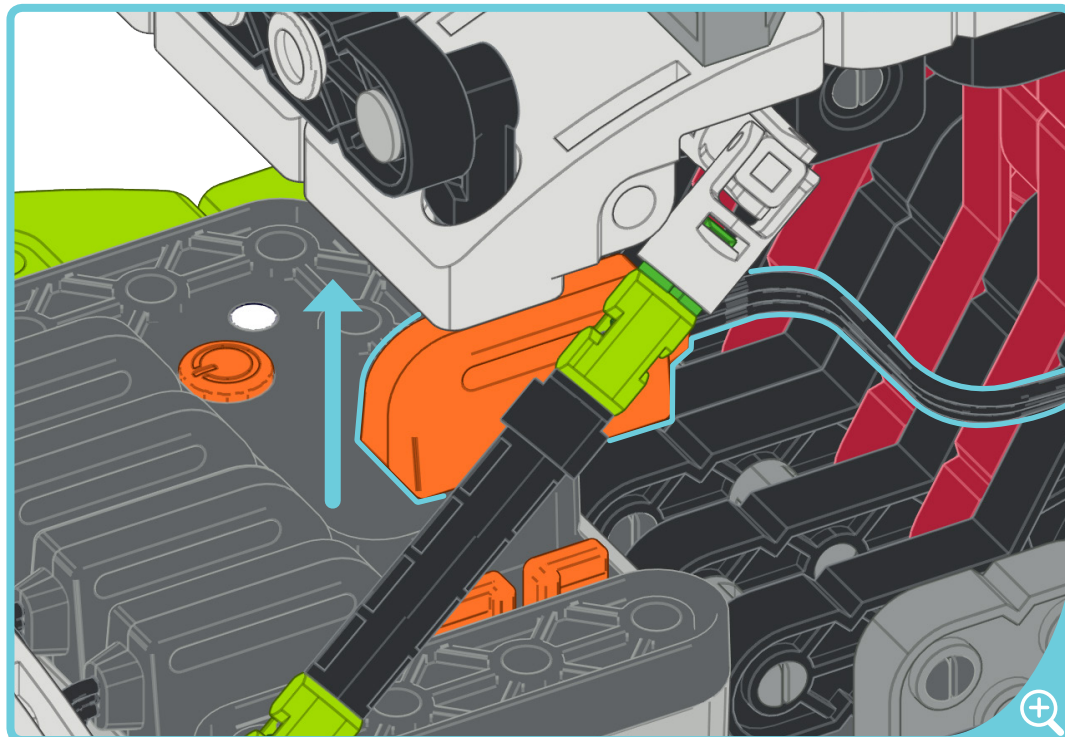
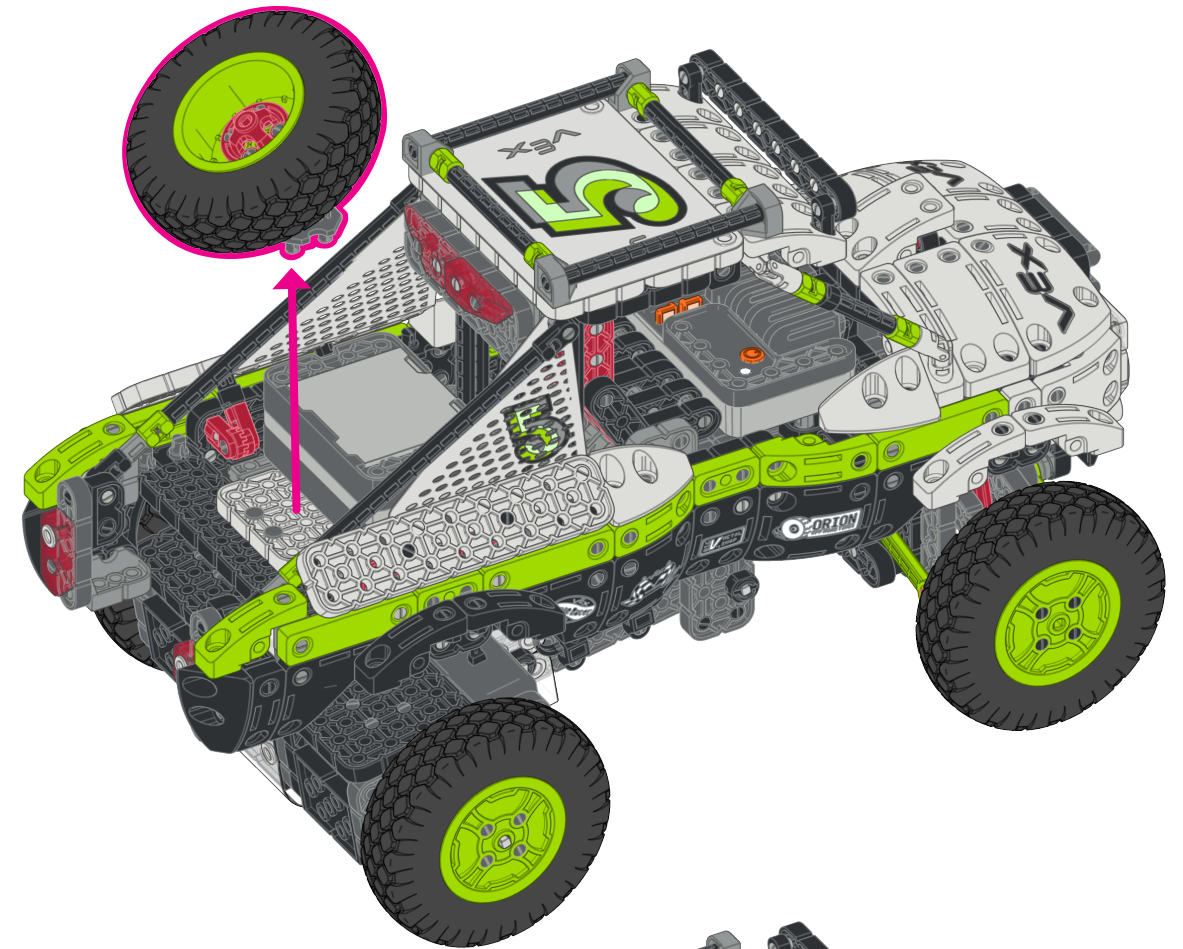



HEXBUG.COM/VEX

HEXBUG® and VEX® are registered trademarks of / est une marque déposée de / es una marca registrada de / ist eine geschützte Marke von / è un marchio registrato di / is een geregistreerd handelsmerk van / é uma marca registrada da Innovation First, Inc. The item inside this package may vary from the photographs and /or illustrations. L'objet contenu dans cet emballage peut être différent des photographies et/ou illustrations. El artículo dentro de este paquete podría variar con respecto a las fotografías y/o ilustraciones. Der Gegenstand in dieser Packung kann von den Fotografien und/oder Illustrationen abweichen. Gli articoli contenuti nell'imballaggio possono variare da fotografie e/o illustrazioni. Het item in deze verpakking kan afwijken van de foto's en/of de illustraties. O item dentro desta embalagem pode variar das fotografias e/ou ilustrações. Please retain package for future reference. Veuillez conserver l'emballage pour toute référence ultérieure. Conserve el paquete para referencia en el futuro. Bitte heben Sie die Packung für künftige Bezugnahme auf. Conservare l'imballaggio originale per riferimenti futuri. Bewaar de verpakking voor verwijzing in de toekomst. Mantenha a embalagem para consulta futura. Please remove all packaging material before giving to children. Veuillez retirer tout élément d'emballage avant de donner à un enfant. Quite todos los materiales del paquete antes de entregar a niños. Bitte entfernen Sie die Verpackung vollständig, bevor Sie den Inhalt Kindern geben. Rimuovere tutto l'imballaggio prima di consegnare il prodotto ai bambini. Verwijder al het verpakkingsmateriaal voordat het aan kinderen wordt gegeven. Retire todo o material da embalagem antes de dar às crianças. This product conforms to the safety regulations. Ce produit est conforme aux réglementations de sécurité. Este producto cumple con las reglas de seguridad. Dieses Produkt entspricht den Sicherheitsvorschriften. Il prodotto è conforme alle norme di sicurezza. Dit product voldoet aan de veiligheidsvoorschriften. Este produto está em conformidade com os regulamentos de segurança. MADE AND ASSEMBLED IN CHINA. FABRIQUÉ ET ASSEMBLÉ EN CHINE. FABRICADO Y ARMADO EN CHINA. HERGESTELLT UND ZUSAMMENGEBAUT IN CHINA. REALIZZATO E ASSEMBLATO IN CINA. GEMAAKT EN GEMONTEERD IN CHINA. FEITO E MONTADO NA CHINA. ©Copyright 2018. All rights reserved. Tous droits réservés. Todos los derechos reservados. Alle Rechte vorbehalten. Tutti i diritti riservati. Alle rechten voorbehouden. Todos os Direitos Reservados.

Custom manufactured in / Fabriqué sur mesure en / Fabricado a medida en / Hergestellt in / Prodotto in / Op maat gefabriceerd in / Fabricado à medida na / China for Innovation First Trading SARL. Distributed in the U.S.A. by / Distribué aux Etats-Unis par / Distribuido en los EE. UU. por / Vertrieb in den USA durch / Distribuito negli U.S.A. da / Gedistribueerd in de VS door / Distribuído nos EUA pela / Innovation First Labs, Inc., 6725 W. FM 1570, Greenville, Texas 75402, U.S.A. Distributed in Europe by / Distribué en Europe par / Distribuido en Europe por / Vertrieb in Europe durch / Distribuito in Europe da / Gedistribueerd in Europe door / Distribuído na Europe pela / Innovation First Trading SARL, 21b rue Gabriel Lippmann L-5365 Munsbach Luxembourg +352 27 86 04 87. Distributed in Canada by / Distribué au Canada par / Distribuido en Canadá por / Vertrieb in Canada durch / Distribuito in Canada da / Gedistribueerd in Canada door / Distribuído no Canadá pela / Innovation First Trading, Inc., 6725 W. FM 1570, Greenville, Texas 75402, U.S.A. www.hexbug.com/contact

PLEASE KEEP THESE INSTRUCTIONS.

Veuillez conserver le mode d'emploi./Por favor conserve la guía de instrucciones./Diese Anleitung bitte aufbewahren./Conservare queste istruzioni.

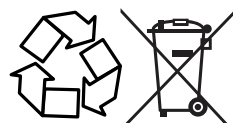

• Battery must be recycled or disposed of properly. • If at any time in the future you should need to dispose of this product please note that Waste Electrical Products should NOT be disposed of with household waste. Please recycle where facilities exist. Check with your Local Authority or retailer for recycling advice. (Waste Electrical and Electronic Equipment Directive).

• La pile doivent être recyclées ou jetées dans un réceptacle prévu à cet effet. • Si vous deviez jeter ce produit un jour, veuillez noter que les appareils électriques N'ONT PAS leur place dans les sacs à déchets. Veuillez le recycler dans un endroit bénéficiant des installations nécessaires. Renseignez-vous auprès des autorités locales ou de votre détaillant pour obtenir des conseils sur le recyclage de cet appareil. (Directive sur le déchet d'équipement électrique et électronique).

• La pila se deben reciclar o desechar de manera adecuada. • Si en cualquier momento en el futuro necesitara desechar este producto por favor tenga en cuenta que los Productos Eléctricos de Desecho NO se deben desechar con los desechos domésticos. Por favor recicle cuando existan las facilidades. Solicite consejo a su autoridad local o comerciante minorista en cuanto a reciclaje. (Directiva de Equipos Eléctricos y Electrónicos de Desecho).

• Die Batterie muss vorschriftsgemäß recycelt oder entsorgt werden. • Bitte beachten Sie, dass elektrische Geräte gemäß der Elektro- und Elektronik-Altgeräte-Verordnung (ElektroV) NICHT als Hausmüll entsorgt werden dürfen. Sollten Sie dieses Erzeugnis zu einem späteren Zeitpunkt entsorgen wollen, geben Sie es bitte zum Recycling. Weitere Informationen dazu erhalten Sie von Ihrem Händler vor Ort oder den örtlichen Behörden.

• La pile devono essere riciclati o smaltiti in modo corretto. • Se in qualsiasi momento in futuro fosse necessario smaltire questo prodotto, si noti che i rifiuti di materiale elettrico NON vanno gettati nei rifiuti domestici. Si prega di riciclare laddove esistano gli appositi impianti. Chiedere consigli sul riciclaggio alle autorità locali o al rivenditore. (Direttiva sui Rifiuti di Apparecchiature Elettriche ed Elettroniche).

This equipment complies with FCC/ IC RSS-102 radiation exposure limits set forth for an uncontrolled environment. This transmitter must not be co-located or operating in conjunction with any other antenna or transmitter. Cet équipement est conforme aux limites d'exposition aux radiations FCC/IC CNR-102 établies pour un environnement non contrôlé. Cet émetteur ne doit pas être situé au même endroit ou fonctionner avec une autre antenne ou un autre émetteur.

**INDUSTRY CANADA COMPLIANCE STATEMENT
CONFORMITÉ AUX NORMES D'INDUSTRIE CANADA**

This device complies with Industry Canada license-exempt RSS Standards. Operation is subject to the following two conditions: 1) this device may not cause interference, and 2) this device must accept any interference, including interference that may cause undesired operation of the device. Cet appareil est conforme aux normes RSS exemptes de licence d'Industrie Canada. Son utilisation doit répondre aux deux conditions suivantes : (1) cet appareil ne doit pas générer d'interférences et (2) il doit supporter toutes les interférences, y compris les interférences susceptibles de provoquer des dysfonctionnements.

Model/Modèle: 406-3368, IC:6811A-RAD10

This device complies with part 15 of the FCC Rules. Operation is subject to the following two conditions: (1) This device may not cause harmful interference, and (2) this device must accept any interference received, including interference that may cause undesired operation. Cet appareil est conforme à la partie 15 des règles de la FCC. Son fonctionnement est soumis aux deux conditions suivantes: (1) cet appareil ne doit pas causer d'interférences nuisibles et (2) cet appareil doit accepter toutes les interférences reçues, y compris celles pouvant entraîner un fonctionnement indésirable.

Google Play and the Google Play logo are trademarks of Google LLC.

Apple and the Apple logo are trademarks of Apple Inc., registered in the U.S. and other countries. App Store is a service mark of Apple Inc., registered in the U.S. and other countries.

BATTERY SAFETY INFORMATION: •Requires 6 x AA (R6) Batteries •Batteries are small objects. •Replacement of batteries must be done by adults. •Follow the polarity (+/-) diagram in the battery compartment. •Promptly remove dead batteries. •Dispose of batteries immediately and properly. •Wear safety glasses when removing used batteries. •DO NOT dispose of batteries in fire, as batteries may explode or leak. •DO NOT mix old and new batteries or types of batteries (i.e.alkaline/standard). •DO NOT recharge non-rechargeable batteries. •DO NOT short-circuit the batteries. •DO NOT heat, dismantle or deform batteries. •Rechargeable batteries are to be removed from the toy before being charged. •Rechargeable batteries are only to be charged under adult supervision. •Use only one VEX Pilot Battery Box with each toy. DO NOT connect more than one VEX Pilot Battery Box together. **INFORMACIÓN DE SEGURIDAD DE LAS PILAS:** •Necesita 6 x AA (R6). •Las pilas son objetos pequeños. •Los adultos deben cambiar las pilas. •Seguir el diagrama de polaridad (+/-) ubicado en el compartimiento de pilas. •Quitar de inmediato las pilas descargadas. •Deseche las baterías usadas de inmediato y de manera correcta. •Use gafas de seguridad al quitar baterías usadas. •NO desechar las pilas en el fuego, ya que pueden explotar o gotear. •NO mezclar pilas usadas con nuevas o distintos tipos de pilas (es decir, alcalinas/estándar). •NO recargar pilas no recargables. •NO colocar las pilas en posición de cortocircuito. •Baterías recargables son de ser quitadas del juguete antes de ser cargadas. •Baterías recargables son de sólo ser cargado bajo supervisión adulta. •Utilice solo un compartimento para pilas VEX Pilot con cada juguete. NO conecte más de un compartimento para pilas VEX Pilot juntos.

CONSIGNES DE SÉCURITÉ CONCERNANT LES PILES: •Exige 6 x AA (R6). •Les piles sont de petits objets. •Le remplacement des piles doit se faire par des adultes. •Suivez le schéma qui indique la polarité (+/-) situé dans le compartiment de la pile. •Ne tardez pas à retirer les piles usées. •Jetez immédiatement et de façon appropriée les batteries usagées. •Portez des lunettes de sécurité lorsque vous retirez des batteries usagées. •NE PAS jeter les piles au feu car elles peuvent exploser ou fuir. •NE PAS mélanger des piles usées avec des piles neuves, ou différents types de piles (par exemple, alcalines/standards). •NE PAS recharger des piles non rechargeable. •NE PAS court-circuiter les piles. •NE PAS chauffer, démonter ou déformer les piles. •Les piles rechargeables sont être enlevées du jouet avant d'est chargé. •Les piles rechargeables sont seulement être chargé sous le contrôle adulte. •Utilisez un seul boîtier de batterie VEX Pilot par jouet. NE branchez JAMAIS plus qu'un boîtier de batterie VEX Pilot ensemble. Le jouet ne doit pas être raccordé à un nombre de sources d'alimentation supérieur au nombre recommandé.

SICHERHEITSMITTEILUNG FÜR BATTERIEN: • 6 x AA (R6). •Batterien sind kleine Gegenstände. •Batterien dürfen nur von Erwachsenen ausgetauscht werden. •Beachten Sie das Polaritätsdiagramm (+/-) im Batteriefach. •Tauschen Sie leere Batterien sofort aus. •Gebrauchte Batterien müssen umgehend und ordnungsgemäß entsorgt werden. •Beim Entfernen von gebrauchten Batterien muss eine Schutzbrille getragen werden. •Entsorgen Sie Batterien NIEMALS in einem Feuer. Batterien können explodieren oder lecken. •Vermischen Sie KEINE alten und neuen Batterien oder unterschiedliche Batterietypen (z.B. Alkali/Normal). •Laden Sie nicht-aufladbare Batterien NIEMALS auf. •Schließen Sie die Batterien NIEMALS kurz. •Aufladbare Batterien sind, aus dem Spielzeug entfernt zu werden, bevor zu werden geladen. •Aufladbare Batterien sind nur, unter erwachsener Aufsicht geladen zu werden. •Verwenden Sie nur einen VEX Pilot-Batteriekasten mit jedem Spielzeug. Schließen Sie NICHT mehr als einen VEX Pilot-Batteriekasten gleichzeitig an.

INFORMAZIONI DI SICUREZZA SULLE BATTERIE: • Richiede 6 x AA (R6) batterie. • Le batterie sono oggetti piccoli. • La sostituzione delle batterie deve essere effettuata dagli adulti. • Seguire il diagramma della polarità (+/-) nell'alloggiamento batteria. • Rimuovere tempestivamente le batterie esaurite. • Smaltire le batterie immediatamente e in modo appropriato. • Indossare occhiali di sicurezza durante lo smaltimento delle batterie. • NON gettare le batterie nel fuoco in quanto potrebbero esplodere o perdere liquido. • NON mescolare batterie vecchie e nuove o tipi diversi di batterie (es. alcaline/standard). • NON ricaricare batterie non ricaricabili. • NON mettere le batterie in corto circuito. •Le batterie ricaricabili devono essere tolte dal gioco prima di essere addebitato. •Le batterie ricaricabili sono solo essere addebitato sotto la supervisione adulta. •Utilizza solo una batteria VEX Pilot per ciascun giocattolo. NON collegare più di una batteria VEX Pilot.

WARNING:
CHOKING HAZARD-Small parts.
Not for children under 3 years.

ADVERTENCIA:
RIESGO DE ASFIXIA- Pequeñas partes.
No para niños menores de 3 años.

AVERTISSEMENT:
RISQUE D'ÉTOUFFEMENT- Comporte de petites pièces.
Ne convient pas aux enfants de moins de 3 ans.

FCC STATEMENT DÉCLARATION DE CONFORMITÉ FCC Model/Modèle: 406-3368, FCC ID:UKU-RAD10

"This device complies with Part 15 of the FCC Rules. Operation is subject to the following two conditions: (1) This device may not cause harmful interference, and (2) this device must accept any interference received, including interference that may cause undesired operation." "Cet appareil respecte la section 15 de la réglementation FCC. L'utilisation est soumise aux deux conditions suivantes : (1) Cet appareil ne doit pas causer d'interférences nuisibles, et (2) cet appareil doit accepter toute interférence reçue, y compris celles pouvant entraîner un dysfonctionnement."

FCC Noted

"This equipment has been tested and found to comply with the limits for a Class B digital device, pursuant to part 15 of the FCC rules. These limits are designed to provide reasonable protection against harmful interference in a residential installation. This equipment generates uses and can radiate radio frequency energy and, if not installed and used in accordance with the instructions, may cause harmful interference to radio communications. However, there is no guarantee that interference will not occur in a particular installation. If this equipment does cause harmful interference to radio or television reception, which can be determined by turning the equipment off and on, the user is encouraged to try to correct the interference by consulting with the dealer or an experienced radio/TV technician for help.

- Reorient or relocate the receiving antenna.
- Increase the separation between the equipment and receiver.
- Connect the equipment into an outlet on a circuit different from that to which the receiver is connected.
- Consult the dealer or an experienced radio/TV technician for help.

NOTE: Changes or modifications not expressly approved by the manufacturer responsible for compliance could void the user's authority to operate the equipment."



Warning: CHOKING HAZARD - Small parts. DO NOT put in nose or mouth.
Avertissement: RISQUE D'ASPHYXIE - Ce produit contient de petits éléments. NE PAS mettre dans le nez ou la bouche.
Advertencia: RIESGO DE ASFIXIA - Contiene piezas pequeñas. NO lo meta en la nariz o la boca.
Achtung: ERSTICKUNGSGEFAHR - Kleinteile. NICHT in die Nase oder den Mund geben.
Attenzione: RISCHIO DI SOFFOCAMENTO - Pezzi piccoli. NON mettere nel naso o nella bocca.

The Bluetooth® word mark and logos are registered trademarks owned by Bluetooth SIG, Inc. and any use of such marks by Innovation First, Inc. is under license.

Remarque FCC

"Cet équipement a été testé et déclaré conforme aux normes s'appliquant aux appareils numériques de Classe B, conformément à la section 15 de la réglementation FCC. Ces normes sont conçues pour fournir une protection raisonnable contre les interférences nuisibles aux installations domestiques. Cet équipement génère, utilise et peut émettre des ondes radioélectriques et, s'il n'est pas installé et utilisé conformément aux instructions, peut entraîner des interférences nuisibles aux communications radioélectriques. Cependant, l'absence d'interférences dans une installation particulière n'est pas garantie. S'il s'avérait que cet équipement génère des interférences nuisibles aux ondes radio et TV, ce qui peut être vérifié en allumant et en éteignant l'appareil, il est recommandé à l'utilisateur d'essayer de corriger les interférences en consultant le revendeur ou un technicien radio/TV qualifié.

- Réorientez ou déplacez l'antenne de réception.
 - Éloignez l'équipement du récepteur.
 - Connectez l'équipement à une prise fonctionnant sur un circuit différent de celui sur lequel est connecté le récepteur.
 - Consultez votre revendeur ou un technicien radio/TV qualifié.
- REMARQUE : N'apportez aucun changement ou modification à l'équipement sauf si cela est explicitement stipulé par le fabricant responsable de la conformité du produit. Si vous effectuez des modifications non autorisées, il pourra vous être demandé d'arrêter d'utiliser l'équipement."



See instructions
Voir les instructions
Vea instrucciones
Siehe die Anleitung
Vedere le istruzioni



 OFFROAD TRUCK
406-4557
LOT #

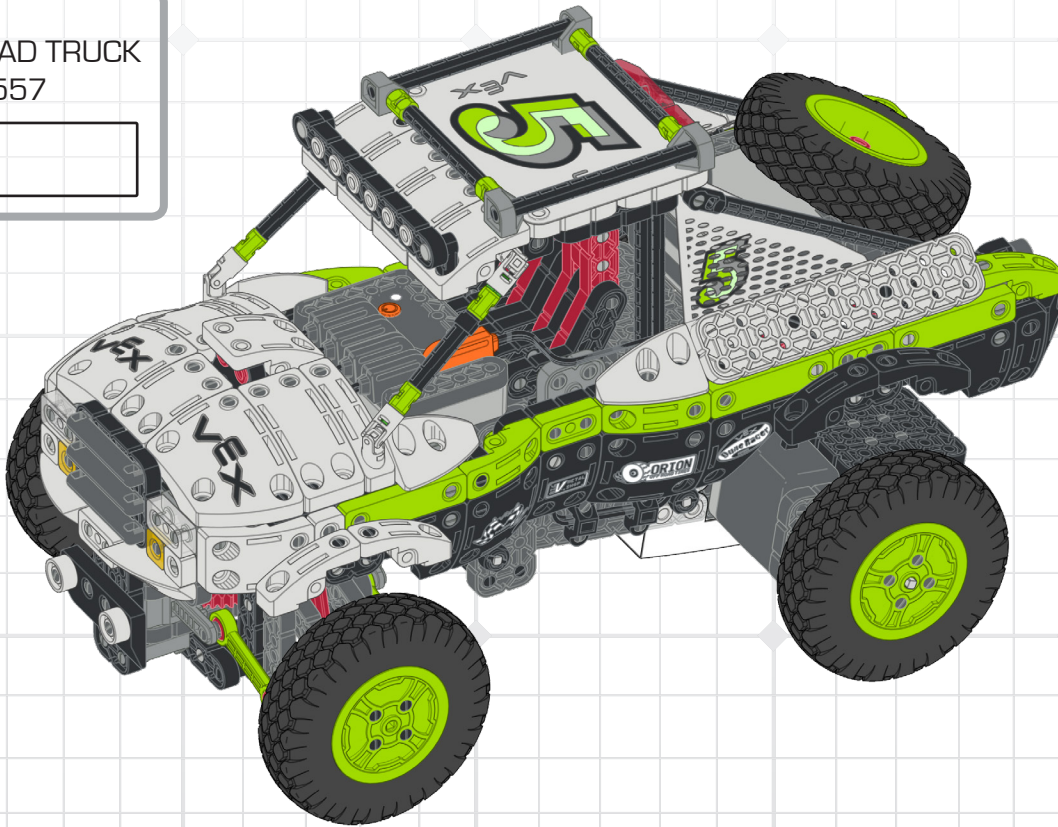

VEX[®]

ROBOTICS

NEED HELP?

¿NECESITAS AYUDA?

BESOIN D'AIDE?

SERVE AIUTO??

HILFE?

HULP NODIG?

POTRZEBUJESZ POMOCY?

[WWW.VEX.COM/HELP](http://www.vex.com/help)