

GH1576

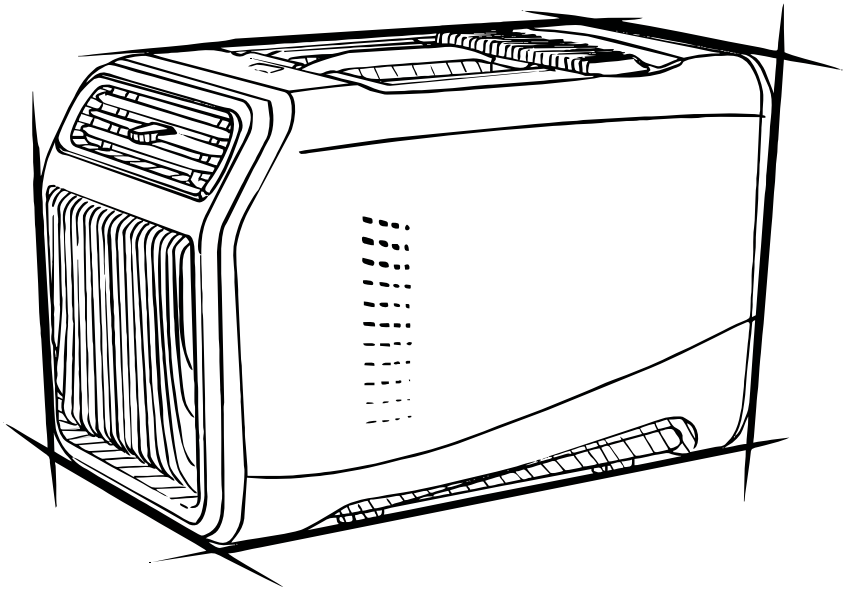

REVERSE CYCLE AIR CONDITIONER



INSTRUCTION MANUAL

CONTENTS

Warnings & Safety Information	1
Before First Use	8
Box Contents	8
Product Diagram	9
Installation & Instructions.....	9
Function and Operation	12
Troubleshooting	13
Care & Maintenance	14
Specifications	15
Warranty Information.....	15

WARNINGS & SAFETY INFORMATION

WARNING: The manufacturer is not responsible for any potential injury from misuse

WARNING

- This product is not suitable for people with weak physical, sensory or mental abilities (including children), unless under the supervision or guidance of a competent person.
- Contact our support when service or repair is needed. Do not disassemble the appliance.
- Do not put your fingers or stick-shaped objects into the air outlet or cooling outlet.
- Do not handle any part of the plug or appliance with wet hands.
- Close attention must be paid when used by or near children. Children should be supervised to ensure that they do not play with the appliance.
- Unplug when it's not in use for an extended period.
- Do not unplug by pulling on the power cord. To unplug, grasp the plug, not the cable.
- The use of an extension cord is not recommended.
- Keep the power cord away from heated surfaces. Do not close a door on the power cord or pull it around sharp edges or corners. Place air conditioner away from traffic areas and away from places where it can be stepped on or tripped over. Do not run the appliance itself over the power cord.
- Do not stretch the power cord or place under strain.
- Use only as instructed in this user manual. Do not perform maintenance on this product.
- Place the appliance in a flat, dry place. If near wall, furniture or curtain, there should be at least 50cm space around the appliance to keep good ventilation.
- This appliance is not intended for use by persons (including children) with reduced physical, sensory or mental capabilities, or lack of experience and knowledge. Children should be supervised to ensure that they do not play with the appliance.
- Children should not play or attempt to clean appliance.
- Do not use means to accelerate the defrosting process or to clean, other than those recommended by the manufacturer.
- The appliance shall be stored in a room without continuously operating ignition sources (for example: open flames, an operating gas appliance or an operating electric heater).
- Do not pierce, burn or expose to flames or heat.

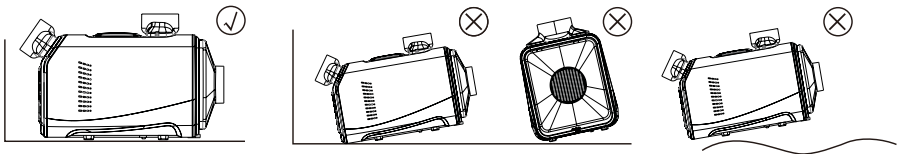

WARNING: This portable air conditioning unit must be placed on a firm flat surface and must not be tilted in any way, failure to setup and operate the unit in this manner will damage the compressor and void warranty.

WARNING: For using R290 refrigerant. This symbol shows that this appliance uses a flammable refrigerant. If the refrigerant is leaked and exposed to an external ignition source, there is a risk of fire.

CAUTION: Risk of fire/flammable materials. The appliance must be installed, used & stored in an area that is greater than 9m²



NB: These symbols on your device mean:

- This appliance is filled with Propane gas R290. Follow strictly the manufacturer's instruction concerning use and repairs!
- Before using this appliance, you must carefully read the entire instruction manual.
- Do not install, operate or store the device in a room with a floor area smaller than 9m²
- Repairs must be performed based on the recommendations from the manufacturing company.
- Note also the information presented on the appliance.
- Do not use means to accelerate the defrosting process or to clean, other than those recommended by the manufacturer.
- The appliance shall NOT be stored in a room with continuously operating ignition sources (for example: open flames, an operating gas appliance or an operating electric heater).
- Do not pierce or burn.
- Be aware that the refrigerants may not contain an odour.
- The appliance should be installed, operated and stored in a room with a floor area according to the amount of refrigerant to be charged. For specific information on the type of gas and the amount, please refer to the relevant label on the unit itself.
- When there are differences between the label and the manual on the Min. room area description, the description on label shall prevail.
- Compliance with national gas regulations shall be observed.
- Keep ventilation openings clear of obstruction.
- The appliance shall be stored so as to prevent mechanical damage from occurring.
- A warning that the appliance shall be stored in a well-ventilated area where the room size corresponds to the room area as specified for operation.
- Any person who is involved with working on or breaking into a refrigerant circuit should hold a current valid certificate from an industry-accredited assessment authority, which authorises their competence to handle refrigerants safely in accordance with an industry recognised assessment specification.
- Servicing shall only be performed as recommended by the equipment manufacturer.
- Maintenance and repair requiring the assistance of other skilled personnel shall be carried out under the supervision of the person competent in the use of flammable refrigerants.

1. Transport of equipment containing flammable refrigerants - see transport regulations
2. Marking of equipment using signs - see local regulations
3. Disposal of equipment using flammable refrigerants - see national regulations.
4. Storage of equipment/appliances - The storage of equipment should be in accordance with the manufacturer's instructions.
5. Storage of packed (unsold) equipment - storage package protection should be constructed such that mechanical damage to the equipment inside the package will not cause a leak of the refrigerant charge. The maximum number of pieces of equipment permitted to be stored together will be determined by local regulations.
6. Information on servicing

Checks to the area

Prior to beginning work on systems containing flammable refrigerants, safety checks are necessary to ensure that the risk of ignition is minimised. For repair to the refrigerating system, the following precautions shall be complied with prior to conducting work on the system.

Work procedure

Work shall be undertaken under a controlled procedure so as to minimise the risk of a flammable gas or vapour being present while the work is being performed.

General work area

All maintenance staff and others working in the local area shall be instructed on the nature of work being carried out. Work in confined spaces shall be avoided.

The area around the workspace shall be sectioned off. Ensure that the conditions within the area have been made safe by control of flammable material.

Checking for presence of refrigerant

The area shall be checked with an appropriate refrigerant detector prior to and during work, to ensure the technician is aware of potentially flammable atmospheres. Ensure that the leak detection equipment being used is suitable for use with flammable refrigerants, i.e. non-sparking, adequately sealed or intrinsically safe.

Presence of fire extinguisher

If any hot work is to be conducted on the refrigeration equipment or any associated parts, appropriate fire extinguishing equipment shall be available to hand. Have a dry powder or CO₂ fire extinguisher adjacent to the charging area.

No ignition sources

No person carrying out work in relation to a refrigeration system which involves exposing any pipe work that contains or has contained flammable refrigerant shall use any sources of ignition in such a manner that it may lead to the risk of fire or explosion. All possible ignition sources, including cigarette smoking, should be kept sufficiently far away from the site of installation, repairing, removing and disposal, during which flammable refrigerant can possibly be released to the surrounding space. Prior to work taking place, the area around the equipment is to be surveyed to make sure that there are no flammable hazards or ignition risks. No Smoking signs shall be displayed.

Ventilated area

Ensure that the area is in the open or that it is adequately ventilated before breaking into the system or conducting any hot work. A degree of ventilation shall continue during the period that the work is carried out. The ventilation should safely disperse any released refrigerant and preferably expel it externally into the atmosphere.

Checks to the refrigeration equipment

Where electrical components are being changed, they shall be fit for the purpose and to the correct specification. At all times the manufacturer's maintenance and service guidelines shall be followed. If in doubt consult the manufacturer's technical department for assistance. The following checks shall be applied to installations using flammable refrigerants:

The charge size is in accordance with the room size within which the refrigerant containing parts are installed;

- The ventilation machinery and outlets are operating adequately and are not obstructed;
- If an indirect refrigerating circuit is being used, the secondary circuit shall be checked for the presence of refrigerant; Marking to the equipment continues to be visible and legible. Markings and signs that are illegible shall be corrected;

Refrigeration pipe or components are installed in a position where they are unlikely to be exposed to any substance which may corrode refrigerant containing components, unless the components are constructed of materials which are inherently resistant to being corroded or are suitably protected against being so corroded.

Checks to electrical devices

Repair and maintenance to electrical components shall include initial safety checks and component inspection procedures. If a fault exists that could compromise safety, then no electrical supply shall be connected to the circuit until it is satisfactorily dealt with. If the fault cannot be corrected immediately but it is necessary to continue operation, an adequate temporary solution shall be used. This shall be reported to the owner of the equipment so all parties are advised.

Initial safety checks shall include:

That capacitors are discharged: this shall be done in a safe manner to avoid possibility of sparking;
That there no live electrical components and wiring are exposed while charging, recovering or purging the system;
That there is continuity of earth bonding.

Repairs to sealed components

During repairs to sealed components, all electrical supplies shall be disconnected from the equipment being worked upon prior to any removal of sealed covers, etc. If it is absolutely necessary to have an electrical supply to equipment during servicing, then a permanently operating form of leak detection shall be located at the most critical point to warn of a potentially hazardous situation.

Particular attention shall be paid to the following to ensure that by working on electrical components, the casing is not altered in such a way that the level of protection is affected. This shall include damage to cables, excessive number of connections, terminals not made to original specification, damage to seals, incorrect fitting of glands, etc. Ensure that apparatus is mounted securely. Ensure that seals or sealing materials have not degraded such that they no longer serve the purpose of preventing the ingress of flammable atmospheres. Replacement parts shall be in accordance with the manufacturer's specifications.

NOTE: The use of silicon sealant may inhibit the effectiveness of some types of leak detection equipment. Intrinsically safe components do not have to be isolated prior to working on them.

Repair to intrinsically safe components

Do not apply any permanent inductive or capacitance loads to the circuit without ensuring that this will not exceed the permissible voltage and current permitted for the equipment in use. Intrinsically safe components are the only types that can be worked on while live in the presence of a flammable atmosphere. The test apparatus shall be at the correct rating. Replace components only with parts specified by the manufacturer. Other parts may result in the ignition of refrigerant in the atmosphere from a leak

Cabling

Check that cabling will not be subject to wear, corrosion, excessive pressure, vibration, sharp edges or any other adverse environmental effects. The check shall also take into account the effects of aging or continual vibration from sources such as compressors or fans

Detection of flammable refrigerants

Under no circumstances shall potential sources of ignition be used in the searching for or detection of refrigerant leaks. A halide torch (or any other detector using a naked flame) shall not be used.

Leak detection methods

The following leak detection methods are deemed acceptable for systems containing flammable refrigerants. Electronic leak detectors shall be used to detect flammable refrigerants, but the sensitivity may not be adequate, or may need re-calibration. (Detection equipment shall be calibrated in a refrigerant-free area.) Ensure that the detector is not a potential source of ignition and is suitable for the refrigerant used. Leak detection equipment shall be set at a percentage of the LFL of the refrigerant and shall be calibrated to the refrigerant employed and the appropriate percentage of gas (25 %maximum) is confirmed. Leak detection fluids are suitable for use with most refrigerants but the use of detergents containing chlorine shall be avoided as the chlorine may react with the refrigerant and corrode the copper pipe-work. If a leak is suspected, all naked flames shall be removed/ extinguished. If a leakage of refrigerant is found which requires brazing, all of the refrigerant shall be recovered from the system, or isolated (by means of shut off valves) in a part of the system remote from the leak. Oxygen free nitrogen (OFN) shall then be purged through the system both before and during the brazing process.

Removal and evacuation

When breaking into the refrigerant circuit to make repairs or for any other purpose conventional procedures shall be used. However, it is important that best practice is followed since flammability is a consideration. The following procedure shall be adhered to: Remove refrigerant; Purge the circuit with inert gas; Evacuate; Purge again with inert gas; Open the circuit by cutting or brazing.

The refrigerant charge shall be recovered into the correct recovery cylinders. The system shall be flushed with OFN to render the unit safe. This process may need to be repeated several times. Compressed air or oxygen shall not be used for this task. Flushing shall be achieved by breaking

the vacuum in the system with OFN and continuing to fill until the working pressure is achieved, then venting to atmosphere, and finally pulling down to a vacuum. This process shall be repeated until no refrigerant is within the system. When the final OF charge is used, the system shall be vented down to atmospheric pressure to enable work to take place. This operation is absolutely vital if brazing operations on the pipe-work are to take place. Ensure that the outlet for the vacuum pump is not close to any ignition sources and there is ventilation available.

Charging procedures

In addition to conventional charging procedures, the following requirements shall be followed. Ensure that contamination of different refrigerants does not occur when using charging equipment. Hoses or lines shall be as short as possible to minimise the amount of refrigerant contained in them.

Cylinders shall be kept upright.

Ensure that the refrigeration system is earthed prior to charging the system with refrigerant.

Label the system when charging is complete (if not already).

Extreme care shall be taken not to overfill the refrigeration system. Prior to recharging the system it shall be pressure tested with OFN. The system shall be leak tested on completion of charging but prior to commissioning. A follow up leak test shall be carried out prior to leaving the site.

Decommissioning

Before carrying out this procedure, it is essential that the technician is completely familiar with the equipment and all its detail. It is recommended good practice that all refrigerants are recovered safely. Prior to the task being carried out, an oil and refrigerant sample shall be taken in case analysis is required prior to re-use of reclaimed refrigerant. It is essential that electrical power is available before the task is commenced.

- Become familiar with the equipment and its operation.
- Isolate system electrically.
- Before attempting the procedure ensure that: Mechanical handling equipment is available, if required, for handling refrigerant cylinders; All personal protective equipment is available and being used correctly; The recovery process is supervised at all times by a competent person; Recovery equipment and cylinders conform to the appropriate standards.
- Pump down refrigerant system, if possible.
- If a vacuum is not possible, make a manifold so that refrigerant can be removed from various parts of the system.
- Make sure that cylinder is situated on the scales before recovery takes place.
- Start the recovery machine and operate in accordance with manufacturer's instructions.
- Do not overfill cylinders. (No more than 80% volume liquid charge).
- Do not exceed the maximum working pressure of the cylinder, even temporarily.
- When the cylinders have been filled correctly and the process completed, make sure that the cylinders and the equipment are removed from site promptly and all isolation valves on the equipment are closed off.
- Recovered refrigerant shall not be charged into another refrigeration system unless it has been cleaned and checked.

Labelling

Equipment shall be labelled stating that it has been de-commissioned and emptied of refrigerant. The label shall be dated and signed. Ensure that there are labels on the equipment stating the equipment contains flammable refrigerant.

Recovery

When removing refrigerant from a system, either for servicing or decommissioning, it is recommended good practice that all refrigerants are removed safely. When transferring refrigerant into cylinders, ensure that only appropriate refrigerant recovery cylinders are employed. Ensure that the correct number of cylinders for holding the total system charge is available. All cylinders to be used are designated for the recovered refrigerant and labelled for that refrigerant (i.e. special cylinders for the recovery of refrigerant). Cylinders shall be complete with pressure relief valve and associated shut-off valves in good working order. Empty recovery cylinders are evacuated and, if possible, cooled before recovery occurs. The recovery equipment shall be in good working order with a set of instructions concerning the equipment that is at hand and shall be suitable for the recovery of flammable refrigerants. In addition, a set of calibrated weighing scales shall be available and in good working order. Hoses shall be complete with leak-free disconnect couplings and in good condition. Before using the recovery machine, check that it is in satisfactory working order, has been properly maintained and that any associated electrical components are sealed to prevent ignition in the event of a refrigerant release. Consult manufacturer if in doubt. The recovered refrigerant shall be returned to the refrigerant supplier in the correct recovery cylinder, and the relevant Waste Transfer Note arranged.

Do not mix refrigerants in recovery units and especially not in cylinders. If compressors or compressor oils are to be removed, ensure that they have been evacuated to an acceptable level to make certain that flammable refrigerant does not remain within the lubricant. The evacuation process shall be carried out prior to returning the compressor to the suppliers. Only electric heating to the compressor body shall be employed to accelerate this process. When oil is drained from a system, it shall be carried out safely.



Exposed to the weather outdoors



Near water



If the power cable wires are frayed or cut



Where small children may be left unattended



If an extension lead may become overloaded



Where the power cable may be damaged



On a slope or uneven surface



Where there is risk of fire or close to a naked flame



Where it may be damaged by chemicals



Where there is a risk of interference by foreign objects



This product is not made for DIY repair







If there is a risk of water falling on the unit

BEFORE FIRST USE

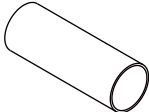
- Prior to using your product, please read all the safety and operating instructions thoroughly.
- Please ensure you follow the steps below before using the product.
- We recommend you keep the original packaging for storing the product when not in use.
- Please pay close attention to the section entitled Warnings & Safety Information.
- Find a safe and convenient place to keep this instruction manual for future reference.
- Unpack the product but retain all packaging materials until you are satisfied that your new product is undamaged and in working order. Ensure you have all accessories listed in this manual.

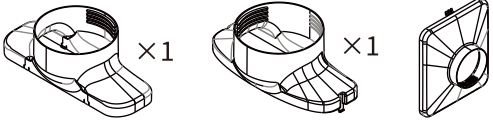
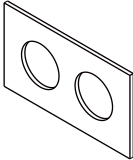
BOX CONTENTS

Air duct	 ×2
Drain pipe	 ×1
Air duct adapter cover	 ×1 ×1 ×1
Window baffle	 ×1
Manual	 ×1

PRODUCT DIAGRAM

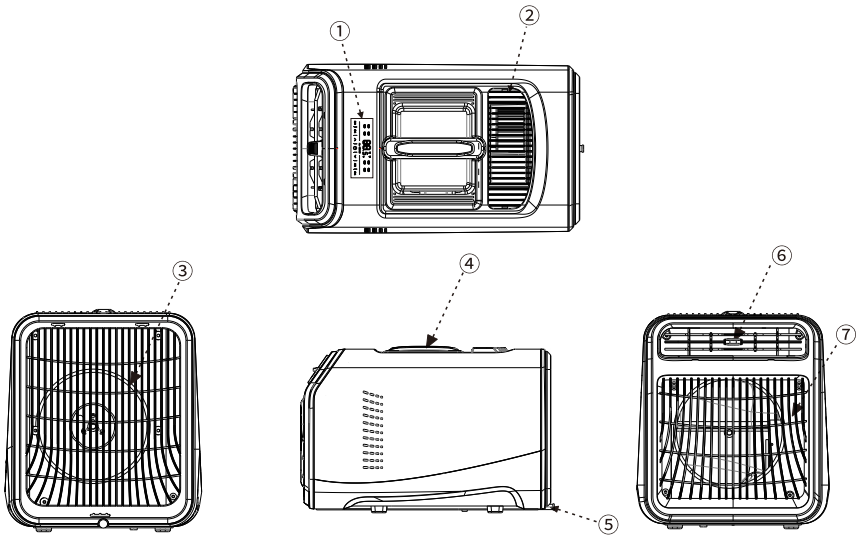

① LED control panel

② Hot air outlet

③ Hot air inlet

④ Handle

⑤ Drainage outlet

⑥ Cooling air outlet

⑦ Cooling air inlet

INSTALLATION INSTRUCTIONS

1. Install air duct if you need to put the air conditioner outside the tent: install the air duct and its adapter cover on the cooling air outlet.

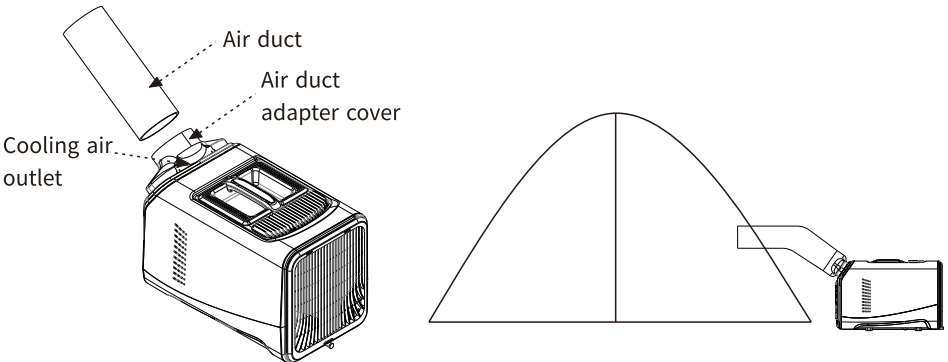

2. Install air duct if you need to put the air conditioner inside the tent: install the air duct and its adapter cover on the hot air outlet & inlet.

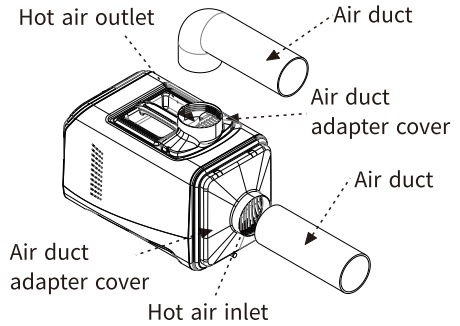

3. Install air duct if the air conditioner is used in an enclosed space: install the air duct and its adapter cover on the hot air outlet & inlet of air conditioner, align and screw the end of the exhaust duct into the hole of the window baffle to deliver the hot air out the window.

*The role of filler: use filler to block the remaining space of the window baffle to prevent hot air of outside from flowing into the room.

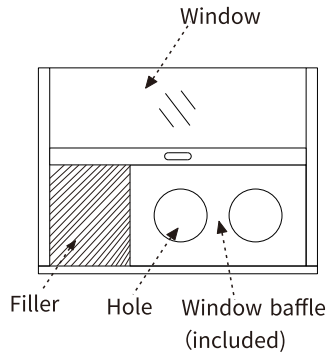

4. Install drain pipe: insert the drain pipe into the drainage outlet protruding at the middle behind the air conditioner. when the drain pipe is led outwards, it is necessary to avoid pipe folding or blocking.

*To use the automatic drainage function, ensure the drain pipe is disconnected. When the drain pipe is connected, water will preferentially drain through the pipe, and the automatic drainage function will not operate.

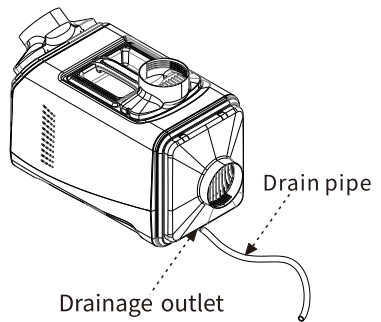

• Installation and Removal of Air Duct Adapter Cover

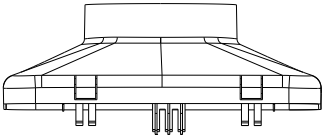
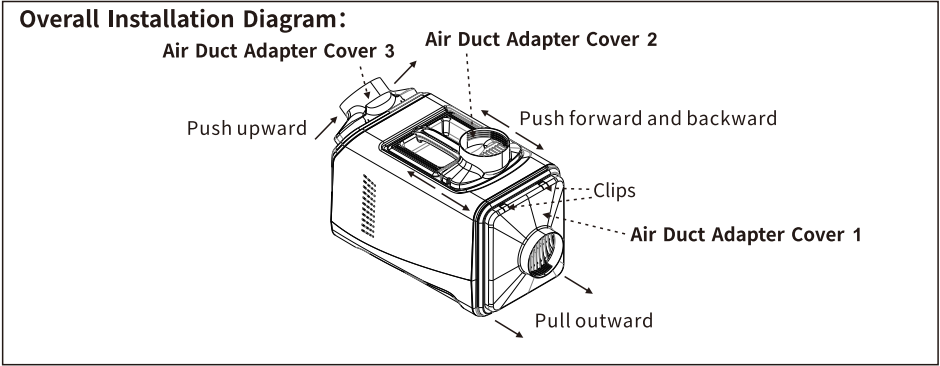

Air Duct Adapter Cover 1: Installed at the hot air inlet

1. Installation: Align the clips on the air duct adapter cover with the reserved mounting positions at the hot air inlet of the air conditioner. First snap the bottom clips into place, then press the two upper clips and push the air duct adapter cover in to finish installation.
2. Removal: Press the two upper clips of the air duct adapter cover and pull outward to remove it.

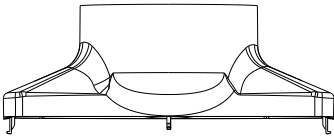

Air Duct Adapter Cover 2: Installed at the hot air outlet

1. Installation: Align the clips on the air duct adapter cover with the reserved mounting positions at the hot air outlet of the air conditioner, and press directly until the clips are locked in place.
2. Removal: Gently push and pull the air duct adapter cover back and forth, then remove it directly.

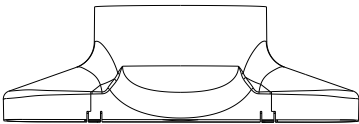

Air Duct Adapter Cover 3: Installed at the cooling air outlet

1. Installation: Align the clips on the air duct adapter cover with the reserved mounting positions at the cooling air outlet of the air conditioner, press and push in until the clips are locked to finish installation.
2. Removal: Gently push the air duct adapter cover upward to remove it.

FUNCTION & OPERATION



LED control panel:

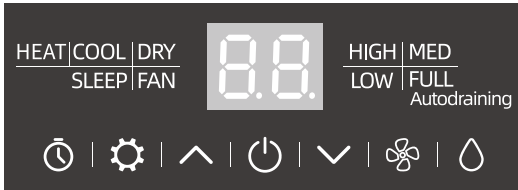





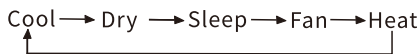

- ON/OFF
- TEMPERATURE UP
- TEMPERATURE DOWN
- SWITCH MODE BUTTON
- FAN SPEED
- EXTERNAL DRAINAGE INDICATION
- TIMING

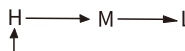
- **Power Supply:** connect to AC220~240V power supply.
- **Display Screen Initialization:** connect to the power supply, the buzzer will make a long beep, and the display will be on for 1 second then enter the normal operating mode.
- **Power ON/OFF:** press to switch ON/OFF.*If you turn on the machine for the first time or shut it down in sleep mode, it will start in cooling mode at 24°C/ 75°F and run at high speed.
- **Timing:** under the running state, press to timing. The value on the screen flashes, and the time interval ranges from 1 to 24 hours. Press or to adjust the specified time, press again to complete the timing. After 10s, the display changes to temperature. Within 10s of completing the adjustment of the specified time, if you don't press to confirm, the timing function will be invalid, the timing indicator will be off, and the screen will be temperature display.
- **Mode conversion:** press to switch between 5 modes: cool, dry, sleep, fan and heat. The corresponding indicator light will be on. The order of mode transitions is as follows:



- **Temperature Setting:** under the cool, heat and sleep mode, press to increase the temperature, and press to decrease the temperature. Long press or to fast adjust the temperature. The temperature setting range: 16~30°C (60~86°F).* under the fan and dry mode, the temperature cannot be adjusted.
- **Fan Speed Setting:** press to switch between 3 modes: H/M/L. The corresponding indicator light is on. When the machine is turned on for the first time, the factory setting is H. After that, the fan speed setting defaults to the fan speed setting before the last shut down. The order of mode transitions is as follows:



- **Automatic Drainage Function:** press  to switch ON/OFF the drainage function. When the water level in the tank is not full, the water level indicator  is white. When the water level in the tank is full, the water level indicator  is red. When the drainage function is turned OFF, the water level indicator  is not illuminated.
(*Automatic drainage fails to work in heating mode.)
- **Temperature Unit Setting:** under the running state, press  and  at the same time to switch Celsius or Fahrenheit. (*Factory setting is °C.)

CARE & MAINTENANCE

Manual Drainage:

- After automatic drainage, a small amount of water may remain inside the unit. To prevent bacterial growth and avoid water leakage when moving the product, remove the drain plug and tilt the unit slightly backward until all residual water is drained.

Cleaning:

- Wipe the air conditioner with warm and wet cloth.
- If it is too dirty, wipe it with neutral detergent, and then dry the water stain with dishcloth.

Plastic parts maintenance:

- To properly protect the air conditioner, it must always be kept clean, and try to avoid oil stain and deformation when using.
- If the oil is attached to the plastic parts for a long time, the plastic is prone to aging or cracking, and gives off odor. Therefore, we should form the habit of regular cleaning.

WARNING!

- It is strictly forbidden to clean the air conditioner in the water directly, so as to prevent the electrical insulation from reducing and rusting.
- The following things will damage the coating, plastic parts and cannot be used for cleaning: alkaline detergent, soap, grinding powder, hot water, brush, Tiana water, gasoline, alcohol.

TROUBLESHOOTING

Issues	Possible cause	Troubleshooting
Air conditioner stops working	Excessive tilt	Put the machine on a horizontal flat surface.
	Have not turned on the power switch	Use as instructed.
	Failure	Contact manufacturer for service.
The air conditioner is not cold enough	Insufficient power	Connect to the correct power source
	Hot pipe is not put in right place	If use the air conditioner in a tent, place the hot pipe in right place and put the other end out of the tent.
	Circumstance influence	Under direct sunlight environment or indoor temperature is too high, please close your window.
Code E1 displayed	Overvoltage protection: Actual voltage exceeds the set value.	Disconnect power to air conditioner for 5 minutes & re-start. If the code shows again, contact manufacturer for service.
Code E2 displayed	Undervoltage protection: Actual voltage is lower than the set value.	Disconnect power to air conditioner for 5 minutes & re-start. If the code shows again, contact manufacturer for service.
Code E0 displayed	Temperature sensor short circuit or open circuit	Disconnect power to air conditioner for 5 minutes & re-start, switching to dry mode, If the code shows again, contact manufacturer for service.
Code H1 displayed	Display panel communication failure	Disconnect power to air conditioner for 5 minutes & re-start. If the code shows again, contact manufacturer for service.
Code H2 displayed	Machine stops when water is full, pump malfunction	Put the air conditioner on a horizontal flat surface and drain it manually, If no water is drained or the code shows again, contact manufacturer for service.

SPECIFICATIONS

REFRIGERANT	R290/110g
COOLING CAPACITY	1500W/5100BTU
HEATING CAPACITY	1600W/5450BTU
RATED VOLTAGE	AC 220~240V
COOLING RATED CURRENT	2.7A
COOLING RATED POWER	600W
HEATING RATED CURRENT	2.7A
HEATING RATED POWER	600W
WORKING TEMPERATURE	16~30°C/60~86°F
NOISE	44-56dB (Sound pressure level)
PRODUCT DIMENSION (L*W*H)	516*305*336 mm
NET WEIGHT	18.5kg
GROSS WEIGHT	22.5kg

*Due to product improvement, the technical information might be different from actual information, please refer to the rating label on the product.

WARRANTY INFORMATION

Our product is guaranteed to be free from manufacturing defects for a period of 12 Months.

If your product becomes defective during this period, Electus Distribution will repair, replace, or refund where a product is faulty; or not fit for intended purpose.

This warranty will not cover modified product; misuse or abuse of the product contrary to user instructions or packaging label; change of mind and normal wear and tear.

Our goods come with guarantees that cannot be excluded under the Australian Consumer Law. You are entitled to a replacement or refund for a major failure and for compensation for any other reasonably foreseeable loss or damage. You are also entitled to have the goods repaired or replaced if the goods fail to be of acceptable quality and failure does not amount to a major failure.

To claim warranty, please contact the place of purchase. You will need to show receipt or other proof of purchase. Additional information may be required to process your claim.

Any expenses relating to the return of your product to the store will normally have to be paid by you. The benefits to the customer given by this warranty are in addition to other rights and remedies of the Australian Consumer Law in relation to the goods or services to which this warranty relates.

This warranty is provided by:

Electus Distribution

Address 46 Eastern Creek Drive, Eastern Creek NSW 2766

Ph. 1300 738 555