

digitech

# Portable Turntable

with Rechargeable Battery



Model:  
**GE4110**

# Instruction Manual

## SAFETY PRECAUTIONS

\* When using electrical units, basic safety precautions should always be followed.

\* Children aged from 8 years and people with reduced physical, sensory or mental capabilities or lack of experience and knowledge can use this unit, only if they have been given supervision or instruction concerning use of the unit in a safe way and understand the hazards involved play with the unit.

\* Unless they are older than 8 and supervised, children should not perform cleaning or user maintenance.

\* This unit is not a toy.

This unit contains no user serviceable parts. If the unit and only of its accessories are malfunctioning or it has been dropped or damaged, only a qualified electrician should carry out repairs. Improper repairs may place the user at risk of harm.

\* Keep the unit and USB cable out of reach of children.

\* Keep the unit and USB cable away from heat or sharp edges that could cause damaged.

\* Keep the unit away from heat sources, direct sunlight humidity, water and any other liquid.

\* Keep the USB cable away from only parts of the unit that may become hot during use.

\* Keep the unit free from dust, lint etc.

Do not immerse the unit in water or any other liquid.

\* Do not operated the unit with wet hands.

\* Do not operate the unit if it has been exposed to water, moisture or any other liquid, to prevent against electric shock, explosion and/or injury to yourself and damage to the unit.

\* Do Not leave the unit unattended whilst connected to another device.

\* Do not use the unit for anything other than those supplied.

\* Do not store the unit in direct sunlight or in high humidity conditions.

- \* Do not put objects into any of the openings.
- \* Do not play music at excessive volume levels as damage to hearing and/or the equipment may occur.
- \* It is imperative to unplug the USB cable after the unit has been used, before it is cleaned and whilst being repaired.
- \* This unit must be placed on a stable, heat resistant surface.



To prevent possible hearing damage, do not listen at high volume levels for long periods of time.

Warning: Keep the unit away from flammable materials.

### **Battery Safety**

The battery unit should not be placed near excessive heat sources, such as fire.

The supply terminals are not to be short-circuited.

Exhausted batteries should be removed from the unit to avoid leakage.

In the event of the battery leaking, do not allow any liquid to come into contact with the skin or eyes.

If contact has been made, wash the affected area with copious of water and seek medical advice. Keep batteries out of reach of children.

Avoid storing in direct sunlight.

Do not dispose of the battery unit in a fire.

Do not crush, puncture, dismantle or otherwise damage the battery.

Do not store above 60°C.

Do not expose batteries to heat or fire as they may explode.

Do not subject the battery(batteries) to mechanical shock.

Do not dispose of the exhausted battery in your household waste.

To dispose of the exhausted battery, take it to your local recycling station. Contacts your local government offices for further details.

This unit is fitted with a 1200mAh battery(non-removable).

## PRODUCT DIAGRAM

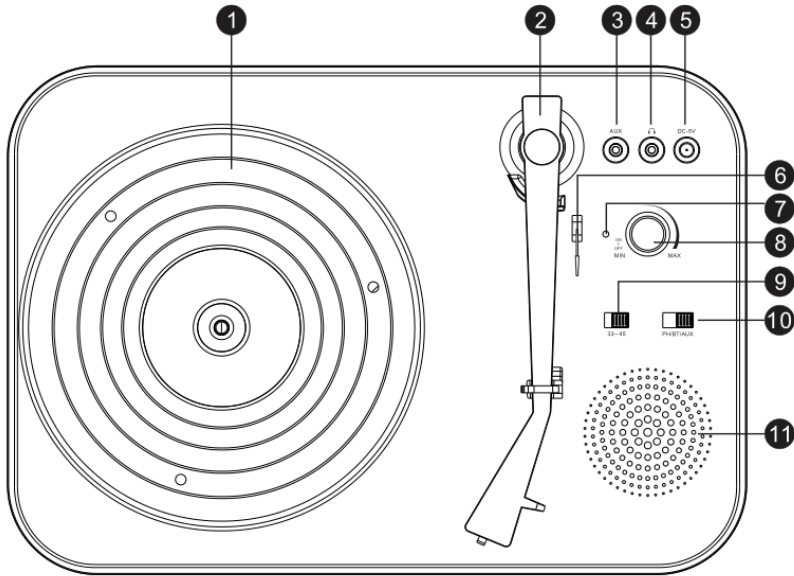

- 1/ Turntable**
- 2/ Tone Arm**
- 3/ AUX Port**
- 4/ Earphone port**
- 5/ DC 5V Charging Port**
- 6/ Arm Raising level**
- 7/ Function indicator light**
- 8/ On/Off Volume Dial**
- 9/ Speed Selector**
- 10/ Mode switch**
- 11/ Speaker**

## FUNCTIONAL DESCRIPTION

### 1/Turntable

Select **Turntable Mode** using the mode selection switch, it will enter into the turntable status automatically.

Remove the protective white needle cover by gently sliding it away from the tone arm (Diagram 1).



Unlock the tone arm from the arm lock by pushing it aside.

Raise the tone arm using the arm raising lever or by carefully lifting it.

Move the tone arm across to the outlet edge of the record and gently lower it, the turntable will begin to spin and play automatically.

Once the tone arm reaches the end of the record at the centre of the turntable, the turntable will stop. Lift away the tone arm and place it back into the armrest.

Secure the tone arm once more by engaging the arm lock.

### 2/Bluetooth

Select **Bluetooth Mode** using the mode selection switch, it will enter into the Bluetooth status automatically.

Then, please open the Bluetooth function on your mobile phone or others Bluetooth device, it will begin to search for the Bluetooth device.

This unit's Bluetooth name is "**GE4110**"; finally, your phone will match with this unit successfully.

### 3/AUX

Select Aux **Mode** using the mode selection switch, it will enter into the AUX status automatically.

Through the AUX cable, the sound can be played.

## 4/Earphone

In any state, insert earphones into the earphone hole.

## 5/Charging the Battery

The Retro Audio Turntable is fitted with a 3.7V 1200mAh Li-ion battery. It is recommended that the battery be charged fully before first use; this will take approximately 6 hours.

Connect the DC input end of the USB charging cable into the 5V 1A DC charging port on the back of the retro Audio Turntable and the other end to a compatible 5V 1A USB port.

Whilst charging, the LED indicator light will illuminate red.

Once the battery has charged fully, the charging indicator light will turn off.

Once the retro Audio Turntable is fully charged, carefully disconnect both ends of the USB charging cable and store it safely for future use.

Noted: The Retro Audio Turntable can still be operated whilst charging the battery but may take longer to fully charge.

## How to replace the stylus

To replace the needle, please refer to the instructions below.

Removing the needle form the cartridge

- a. Place a screwdriver at the tip of the needle heads hell and push downwards in the direction shown in sketch "A"
- b. Remove the needle head shell by pulling it forwards and pushing downwards.

Inserting the needle

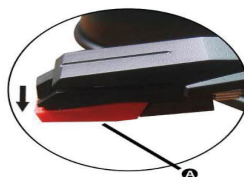
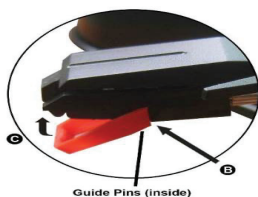

c. Hold the tip of the needle head shell and insert it by pressing in the direction illustrated by “B”

d. Push the needle head shell upwards in the direction illustrated by “C” until the needle locks into the tip position.

## TECHNICAL SPECIFICATIONS

Turntable Drive System:	Belt Drive
Cartridge Type:	Ruby Stylus
Input:	3.5mm Aux
Outputs:	3.5mm Aux
Audio Sources:	Bluetooth®, 3.5mm Aux
Speed:	33/45RPM
Speakers:	1 x 3W
Battery Life:	Up to 3-4 Hours
Battery:	3.7V Li-ion, 1200mAh
Power:	5VDC, 1A
Dimensions:	370(W) x 253(D) x 85(H)mm

## PACKAGE CONTENTS

- 1 x Portable Turntable
- 1 x 45RPM Adaptor
- 1 x 3.5mm Aux Cable
- 1 x USB Charging Cable

Distributed by:  
Electus Distribution Pty Ltd  
46 Eastern Creek Dr,  
Eastern Creek NSW 2766 Australia  
Ph 1300 738 555  
Int'l +61 2 8832 3200  
Fax 1300 738 500

[www.electusdistribution.com.au](http://www.electusdistribution.com.au)