

digitech

# Solar Emergency Handcrank Radio

with LED Light, SOS Siren & 3.5mm Earphone Jacks



Model:  
**AR1944**

# Instruction Manual

## PACKAGE CONTENTS:

- AM/FM Radio
- Micro USB Charging Cable
- Wrist Strap
- Instruction Manual

## RADIO OPERATION:

### TUNING

Rotate the tuning knob to select your frequency. The tuning indicator will light up when a strong signal is found.

### VOL +/VOL-

Rotate the VOL+/VOL- knob to adjust the volume.

### LIGHT ON/OFF/SOS

Adjust the LIGHT ON/OFF/SOS button to turn the LIGHT ON & OFF. Switch to SOS to emit an emergency alarm.

### OFF/FM/AM

Select OFF/FM/AM with the BAND selector to turn off your radio. Select your desired band. Extend the antenna to get a better signal.

### LED READING LAMP

Pull the solar panel up at a 90° angle to activate the reading light.

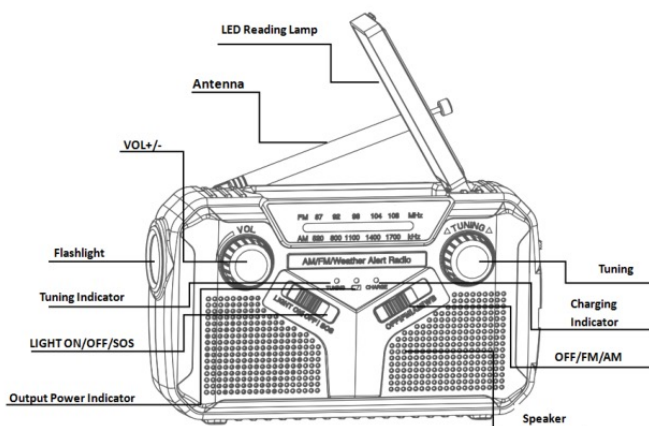

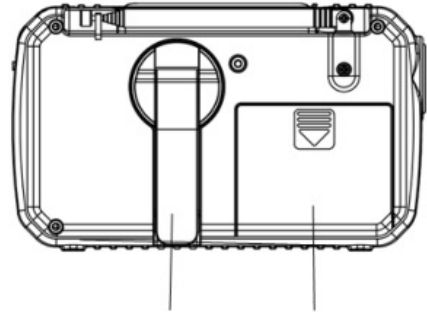
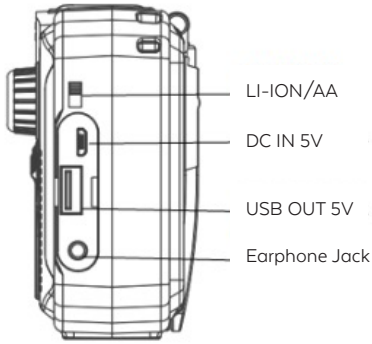

## POWER YOUR RADIO:

Before you power your radio, make sure to read the SAFETY INSTRUCTIONS.

### SOLAR POWER

- Position the radio in direct sunlight to ensure that the solar panel receives adequate exposure.
- Do not leave your radio in a hot area for extended periods, such as a hot car.
- Turn off the radio when charging.

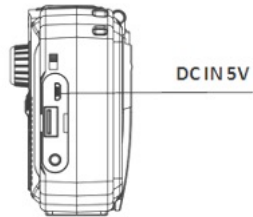
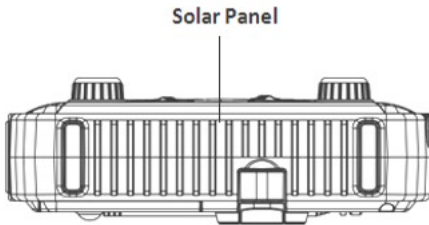

## DC IN 5V CHARGING

- To charge the radio, insert the supplied USB cable into a USB power source. Insert the Micro USB connector located under the rubber seal.
- The charging indicator will flash red as the battery charges. It takes 2.5 hours for the internal 18650 2500mAh LI-ION battery to be fully charged.
- When fully charged, the battery will provide 11-12 hours of radio play (depending on sound level), 41 hours of flash light use, or 48 hours of reading lamp use.

## HAND CRANK

- Unfold the radio's handle from the back and rotate it in either direction.
- Turn the hand crank for 5 minutes to activate the internal battery for initial use.
- Five minutes of winding results in 15-20 minutes of radio play (at maximum volume), 2 hours of reading lamp use, and 1.4 hours of flashlight use.

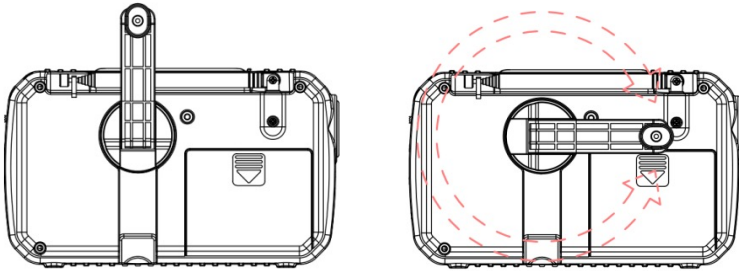

## 3 x AA BATTERY

- This radio can also be powered by three AA batteries (not included).
- Remove the battery compartment cover and insert three AA batteries.
- Replace the battery compartment cover and switch the radio battery switch to the 'AA' position to turn the radio on.
- If you want to store your radio for extended periods, please be sure to remove the batteries to avoid corrosion damage.

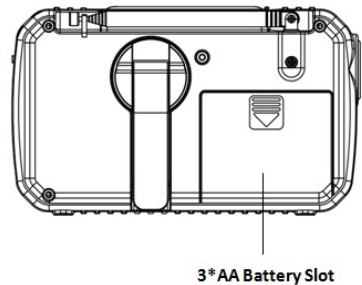

## EXTERNAL DEVICE CHARGING

- Select the “LI-ION” position on the side panel, as shown in the diagram below.
- Insert the USB cable into the ‘USB out’ port to connect your devices to charge.
- You can charge USB devices with three AA batteries. You can also use the dynamo function and crank at 130-150 RPM.

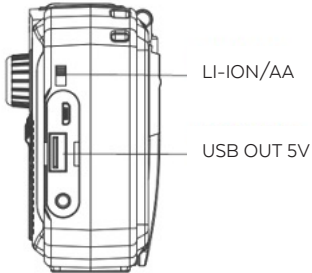

### Note:

- This feature is only for charging USB devices during emergency situations. Do not use it regularly as a power bank.
- The supplied charging cable is only for charging the radio from a USB power source or charging device that accepts Micro-USB.

## SPECIFICATION:

Product Name	AM/FM Dynamo Hand Crank Radio With SOS/Torch/Reading lamp/Phone Charger/Solar Panel
Color	Yellow
Material	ABS Plastic
AM	520-1620KHz
FM	87-108MHz
Power Source/ Charging options	Solar Panel/Hand Crank/2500MAh rechargeable battery/ backup 3 x AA Battery (not included)
Features	Solar Panel/ Built-in speakers/SOS/High-sensitivity Antenna/Earphone jack/USB out 5V/DC in 5V/Torch 1W/ Reading Lamp 2W/Hand Crank/Hand strap
Dimensions	15.5 x 4.2 x 9.4cm
Weight	364g

## SAFETY INSTRUCTIONS:

- Dropping this radio can cause injury or damage. The unit will not resist strong impact or contact with corrosive liquids.
- This radio is not waterproof, only water-resistant to an extent. Keep the unit dry, as moisture and liquids can cause damage.
- Wind the crank for 3-5 minutes before using it to activate and keep the internal battery healthy.



Distributed by:  
Electus Distribution Pty Ltd  
46 Eastern Creek Dr,  
Eastern Creek NSW 2766 Australia  
Ph 1300 738 555  
Int'l +61 2 8832 3200  
Fax 1300 738 500

[www.electusdistribution.com.au](http://www.electusdistribution.com.au)

Made in China