



DIGITAL ANTENNA

Digital TV Antenna

AE3000



CONTENTS

FEATURES.....	2
SUPPLIED WITH	2
DESCRIPTION.....	3
CONSIDERATIONS.....	3
INSTALLATION	3
Installation and mounting hardware.....	3
Pole mounted – Centre.....	4
Pole mounted – Offset.....	6
Mast mounted	8
Fitting the 'F' connector to the free-end of the coax cable.....	9
SPECIFICATIONS	10
GME WARRANTY AGAINST DEFECTS	11
CONTACT DETAILS	12

FEATURES

- Active DVB-T digital TV antenna
- Built-in amplifier (20 dB gain)
- Compact slim design
- Weather resistant UV stabilised housing
- Versatile mounting options
- Suitable for use on boats, caravans and RVs
- Designed and manufactured in Australia

SUPPLIED WITH:

- Antenna radome
- 10 m coax cable
- Connection and mounting hardware including stainless nuts, bolts, washers and screws.
- 350 mm (13.8") pole with end brackets for deck mounting
- Bracket for mast mounting
- Power injector

DESCRIPTION

The GME AE3000 is a dual loop active broadband digital TV antenna designed specifically for marine and mobile use.

This unique broadband antenna ensures good balanced reception on all digital Free-To-Air TV channels. The AE3000 will also provide reception for available analogue Free-To-Air TV channels that are within its frequency range (refer to specifications). Unlike traditional TV antennas the AE3000 is omnidirectional so it will continue to provide good reception if your vessel changes course or swings at anchor. For land use this means that there is no requirement to aim the antenna at each new site or when switching between stations located in different directions.

The AE3000 has a built-in amplifier using the latest technology to ensure low noise and minimum interference from strong local signals.

The antenna and amplifier are mounted in a weatherproof plastic radome. The radome is UV stabilised to resist the effects of long term exposure to sunlight. All screws and bolts are high grade stainless steel to resist corrosion in the harsh marine environment. The antenna is fed by a 10 metre length of high quality coax cable which carries 12V DC to power the in-built amplifier and feeds signals from the antenna to the TV receiver.

CONSIDERATIONS

Careful consideration should be given to the best mounting position for the AE3000. The strength of television signals can be reduced significantly once the line of sight distance is exceeded so the AE3000 should be mounted as high as possible to ensure the best reception.

Many modern vessels have a Targa arch which is an ideal location for GPS, radar and TV antennas. If the AE3000 is to be mounted on an arch or similar elevated flat surface, the included 350 mm (13.8") pole mount with moulded end brackets and slope adjusting spacers can be used.

Alternatively the AE3000 can be mounted on a 25 mm (1") diameter alloy or stainless steel pole.

For yachts or other masted vessels the AE3000 can also be mounted to the mast using the mast mount bracket (included).

INSTALLATION

All required hardware is included to support pole mount, offset pole mount and mast mount installations. Installation and mounting hardware have been separated and sealed in labelled plastic bags to help with identifying the correct hardware for your chosen installation. Please refer to these labels in the instructions below.

INSTALLATION AND MOUNTING HARDWARE

LABEL	DESCRIPTION	QTY	PART NUMBER
(A)	M5 x 35 mm pan head S/S bolt	3	74M5035PFM
(B)	6 mm x 16 mm S/S grub screws	2	74M6016GKZ
	Allen key 3 mm	1	80005
(C)	Slope adjustors	2	660026
(D)	M5 x 20 mm pan head S/S bolt	3	74M5020PFZ
(E)	M4 x 12 mm S/S bolt	2	74M4012PFZ
	M4 S/S nut	2	510037
	M4 S/S washer	4	910093
(F)	6 gauge x 12 mm S/S screw	4	74A6G12PFM
(G)	Tube spanner	1	61A1569
(H)	'F' to PAL adaptor	1	01A004
(I)	Coax 'F' connector – twist type	1	730083
(J)	Power injector	1	PIK3000

POLE MOUNTED – CENTRE

The AE3000 can be pole mounted using the 350 mm pole and end brackets provided. For centre mounting, one of the end brackets should be bolted directly to the bottom-centre of the antenna base. The cable can then be fed to the television receiver via a suitable path or hole in the mounting surface (fig 1).

Fig 1 – Pole mounted – centre

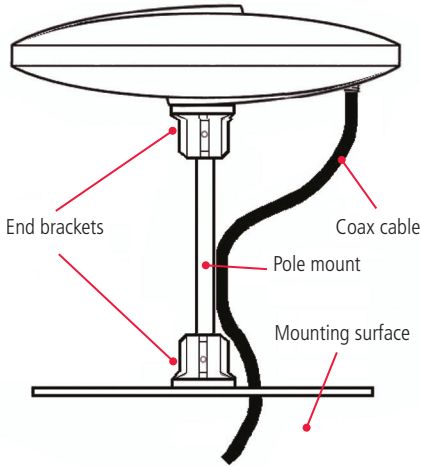

1. Position one of the end brackets over the three mounting holes in the bottom centre of the AE3000 (fig 2).
2. Mount the end bracket using three 35 mm M5 bolts (A). Do not over tighten.
3. Insert the pole into the end bracket and align the three holes (fig 3a).
4. Install three 6 mm grub screws (B) into the collars in the end bracket. Ensure all three grub screws locate into the holes in the pole before tightening them using the Allen key provided. Tighten evenly to centre the pole in the bracket.

5. Repeat steps 3 and 4 to install the second end bracket to the other end of the pole.
6. Two slope adjusters (C) have been included to assist when mounting the antenna pole on a sloping surface. If required, install one or more slope adjusters between the end bracket and the mounting surface and rotate them until the pole is vertical (fig 3b). Fix the end bracket to the mounting surface using suitable 5 mm diameter stainless steel screws or bolts (not included).
7. Fit the 'F' connector on the 10 m length of coax cable to the antenna socket on the AE3000. Tighten using the tube spanner (G) provided (fig 4). Rotate the spanner clockwise to tighten the connector. Do not over tighten.

Feed the length of the coax to the television receiver.

Fig 2 - Centre mounting

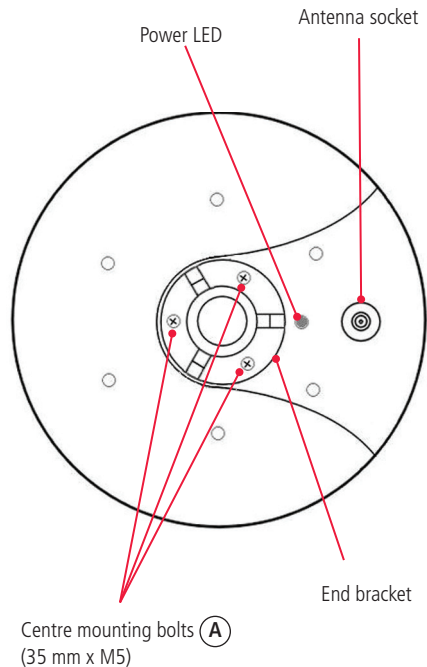

Fig 3a – Installing the end bracket

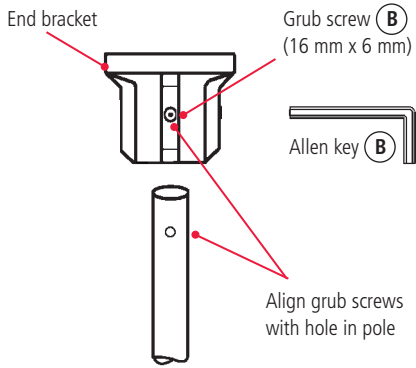

Fig 3b – Mounting the pole using slope adjustors

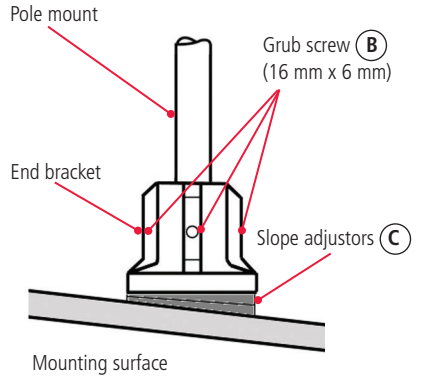
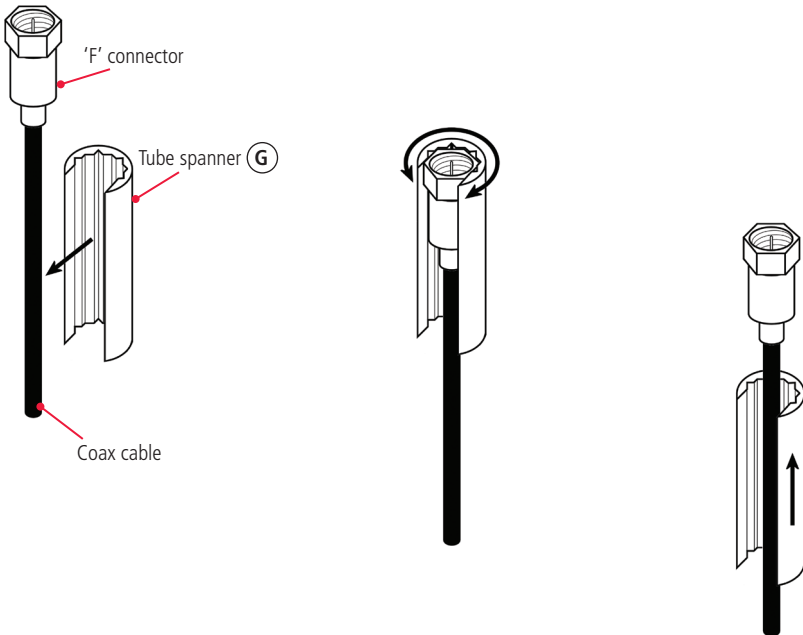

Fig 4 – Using the tube spanner



POLE MOUNTED – OFFSET

The AE3000 can also be offset mounted using the included side bracket along with the pole and end brackets. This allows the pole to be installed directly over the antenna socket with the antenna cable passing through the hollow centre of the pole directly into the vessel to provide a weather proof cable installation (fig 5).

Fig 5 – Complete pole mount offset assembly

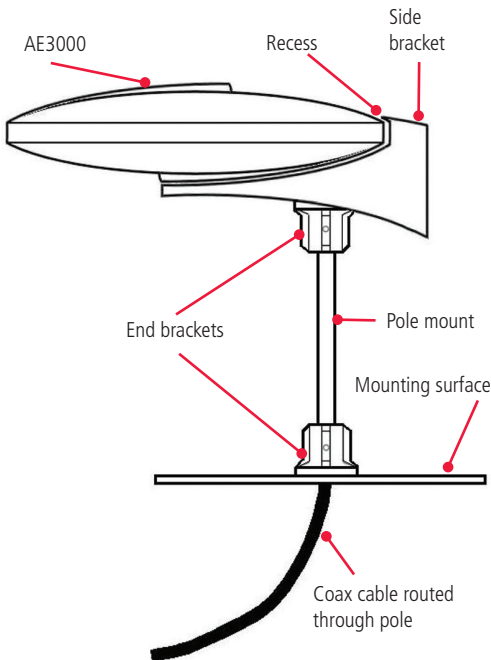

1. Position the side bracket over the edge of the AE3000 ensuring the bracket fits into the recess at the top edge of the antenna radome (fig 6a).
2. Align the three holes at the centre of the antenna with those in the side bracket and fix the side bracket to the antenna using three 35 mm M5 bolts (A) (fig 6b).
3. Insert the pole into one of the end brackets and align the three holes (fig 3a).
4. Install three 6 mm grub screws (B) into the collars in the end bracket. Ensure all three grub screws locate into the holes in the pole before tightening them using the Allen key provided. Tighten evenly to centre the pole in the bracket.
5. Repeat steps 3 and 4 to install the second end bracket to the other end of the pole.
6. Feed the end of the coax cable with the 'F' connector through the pole mount assembly (fig 6c).
7. Use the tube spanner (G) to screw the 'F' connector onto the antenna socket (fig 6d). Rotate the spanner clockwise to tighten the connector. Do not over tighten.

Fig 6a – Position of side bracket

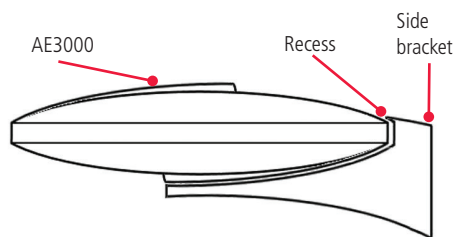

Fig 6b – Mounting points

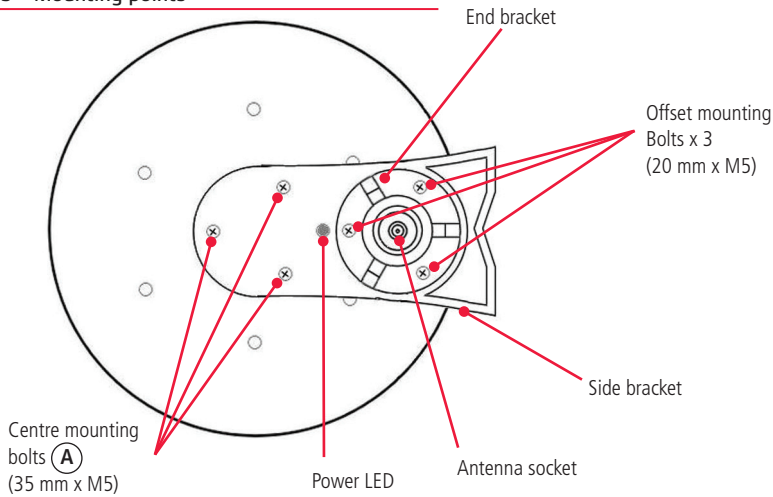

Fig 6c – Cable assembly

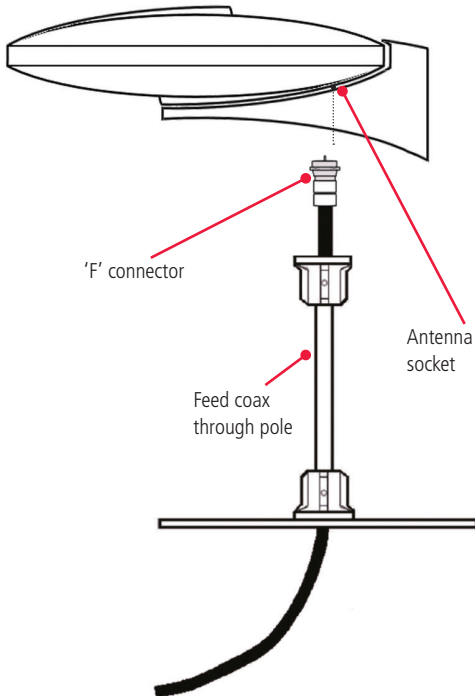
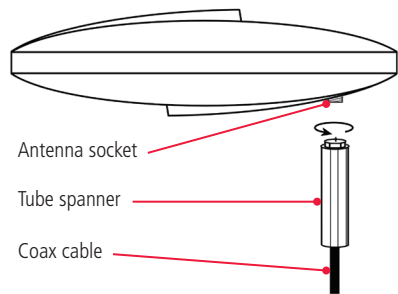

Fig 6d – Connecting the cable to the antenna



8. With the 'F' connector fitted, position the end bracket/pole assembly over the antenna socket and align the three mounting holes with those on the antenna. Fix the end bracket using three 20 mm x M5 bolts (D) (fig 6b).

Feed the length of the coax to the television receiver.

MAST MOUNTED

The AE3000 can be mounted to an existing mast using the side bracket and additional mast mount bracket. The mast mount bracket supports mast diameters of around 110 mm but can be bent to

adjust to small variations in mast diameters. The cable can be run down the mast to the television receiver.

Fig 7 – Mast mounting

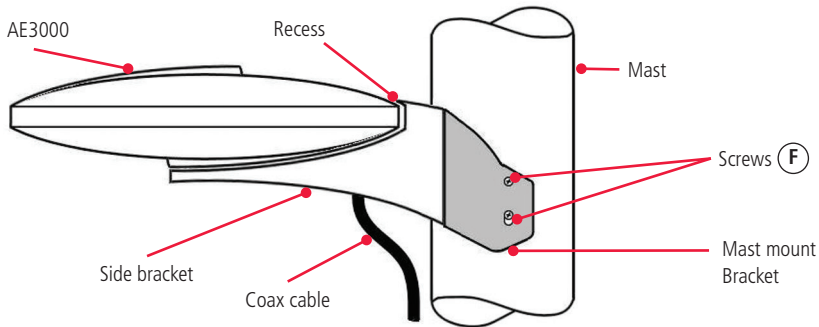

1. Position the side bracket over the edge of the AE3000 ensuring the bracket locates into the recess in the top edge of the antenna radome (fig 6a).
2. Align the three holes at the centre of the antenna with those in the side bracket and fix the side bracket to the antenna using three 35 mm M5 bolts (A) (fig 8).
3. Using the locating tabs, slide the mast mount bracket onto the side bracket and secure using

the stainless steel M4 bolts, nuts and washers provided (E).

4. Attach the mast mount bracket to the mast using 4 x 6 gauge screws (F).
5. Fit the 'F' connector to the antenna socket using the tube spanner (G) (fig 6d). Rotate the spanner clockwise to tighten the connector. Do not over tighten.

Feed the cable down the mast to the television.

Fig 8 – Mast mount assembly

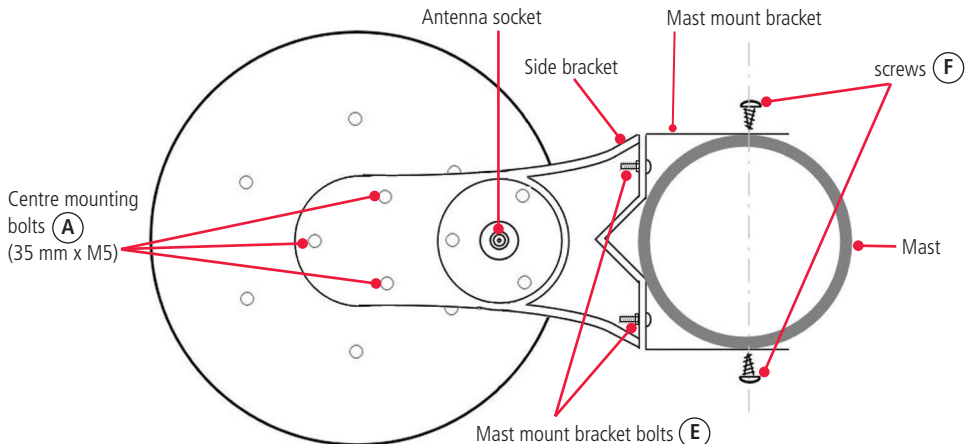

FITTING THE 'F' CONNECTOR TO THE FREE-END OF THE COAX CABLE

The free-end of the coax cable has been pre-cut to take the additional 'F' connector supplied (I). Before fitting the 'F' connector, first route the coax towards the television.

Once the cable has been routed to the television, slide the outer covering off the end of the cable to reveal the pre-cut centre wire and outer shield (fig 9a).

Insert the cable into the back of the 'F' connector and screw the connector onto the cable as far as possible. When fitted correctly the centre pin of the coax should protrude through the front of the connector as shown (fig 9b). Trim off any excess braid if required.

Fig 9a – Pre-cut coax cable

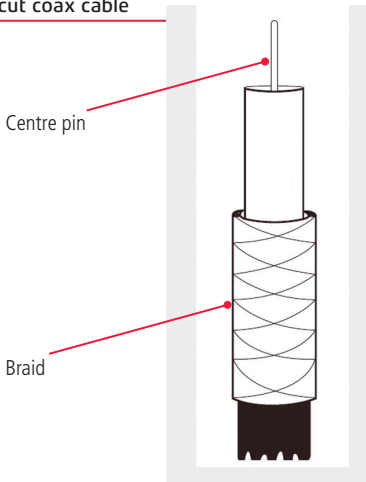
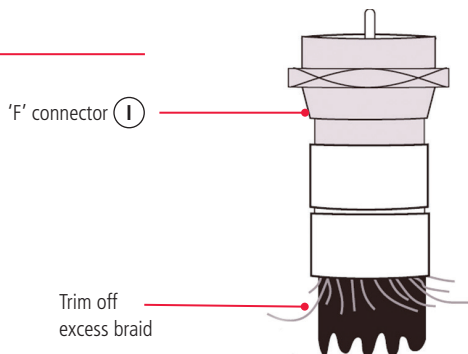

Fig 9b – Fitting the 'F' connector



Installing the power injector

The power injector is designed to pass power into the AE3000 from your 12 volt power source while simultaneously feeding the TV signal out to your television. The power injector has two 'F' type sockets labelled 'To Television' and 'To Antenna'.

1. Connect the long coax cable from the AE3000 to the socket on the power injector labelled 'To Antenna' (fig 10).
2. Connect the short coax cable from the television to the socket labelled 'To Television' on the power injector via the included 'F' to PAL adaptor (H).
3. Connect the red and black leads from the power injector to a 12 volt battery or power source. Connect the red lead to positive and the black lead to negative. Check that the power LED on the underside of the AE3000 is lit.

Fig 10 – Installing the power injector

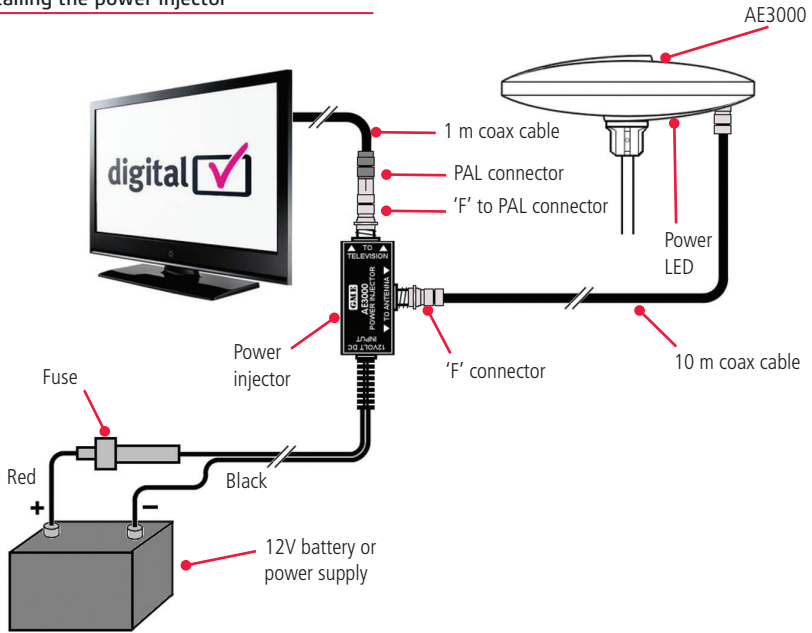

SPECIFICATIONS

Antenna Type: Dual loop

Frequency Range: Free-to air digital television band 174 – 860 MHz

Polarisation: Horizontal

Reception Pattern: Omni directional

Amplifier: Low noise GaAs MESFET

Gain: 20 dB +/- 0.5 dB

Noise Figure: >2 dB

Output Impedance: 75 Ohms

Injector: PIK3000

Supply Voltage: 10.5 – 14.5V DC negative ground

Current Consumption: 120 mA (typical)

Protection: Reverse polarity and surge

Connector: Standard 'F' type

Down Lead: 10 metres RG6/U with connectors

Radome: White ABS UV stabilised plastic alloy, 280 mm diameter, 55 mm high.

Mounting: Accepts 25 mm (1") standard diameter pole. 350 mm (13.8") pole with end brackets supplied. Also includes mast mount bracket for masts up to 100 mm (3.9") diameter.

All specifications are typical and subject to change without notice or obligation.

1. Consumer guarantees

- 1.1 Our goods come with guarantees that cannot be excluded under the Australian Consumer Law. You are entitled to a replacement or refund for a major failure and for compensation for any other reasonably foreseeable loss or damage. You are also entitled to have the goods repaired or replaced if the goods fail to be of acceptable quality and the failure does not amount to a major failure.
- 1.2 To the extent we are able, we exclude all other conditions, warranties and obligations which would otherwise be implied.

2. Warranty against defects:

- 2.1 This Warranty is in addition to and does not limit, exclude or restrict your rights under the Competition and Consumer Act 2010 (Australia) or any other mandatory protection laws that may apply.
- 2.2 We warrant our goods to be free from defects in materials and workmanship for the warranty period (see warranty table) from the date of original sale (or another period we agree to in writing). Subject to our obligations under clause 1.2, we will at our option, either repair or replace goods which we are satisfied are defective. We warrant any replacement parts for the remainder of the period of warranty for the goods into which they are incorporated.
- 2.3 To the extent permitted by law, our sole liability for breach of a condition, warranty or other obligation implied by law is limited.
 - (a) In the case of goods we supply, to any one of the following as we decide –
 - (i) The replacement of the goods or the supply of equivalent goods.
 - (ii) The repair of the goods.
 - (iii) The cost of repairing the goods or of acquiring equivalent goods.
 - (b) In the case of services we supply, to any one of the following as we decide –
 - (i) The supplying of the services again
 - (ii) The cost of having the services supplied again.
- 2.4 For repairs outside the warranty period, we warrant our repairs to be free from defects in materials and workmanship for three months from the date of the original repair. We agree to re-repair or replace (at our option) any materials or workmanship which we are satisfied are defective.
- 2.5 We warrant that we will perform services with reasonable care and skill and agree to investigate any complaint regarding our services made in good faith. If we are satisfied that the complaint is justified, and as our sole liability to you under this warranty (to the extent permitted at law), we agree to supply those services again at no extra charge to you.
- 2.6 To make a warranty claim you must before the end of the applicable warranty period (see warranty table), at your own cost, return the goods you allege are defective, provide written details of the defect, and give us an original or copy of the sales invoice or some other evidence showing details of the transaction.

Before returning any goods you will be required to follow the available options:

Contact our Customer Support Team on 1300 463 463 or techsupport@gme.net.au.

A customer support team member will troubleshoot and validate if your product is faulty. If so, they will email you a product RMA (Return Material Authorisation).

Products that are authorised to be returned to Standard Communications must include the following:

RMA form (Return Material Authorisation)

A copy of your proof of purchase, the faulty product, including all accessories

- 2.7 Send your claim to:
GME Pty Ltd.
17 Gibbon Rd, Winston Hills, NSW 2153, Australia.
Tel: (02) 8867 6000 Fax: (02) 8867 6199.
Email: servadmin@gme.net.au

2.8 If we determine that your goods are defective, we will pay for the cost of returning the repaired or replaced goods to you, and reimburse you for your reasonable expenses of sending your warranty claim to us.

3. What this warranty does not cover:

3.1 This warranty will not apply in relation to:

- (a) Goods modified or altered in any way.
- (b) Defects and damage caused by use with non Standard Communications products.
- (c) Repairs performed other than by our authorised representative.
- (d) Defects or damage resulting from misuse, accident, impact or neglect.
- (e) Goods improperly installed or used in a manner contrary to the relevant instruction manual; or
- (f) Goods where the serial number has been removed or made illegal.

4. Warranty period:

4.1 We provide the following warranty on GME and Kingray products. No repair or replacement during the warranty period will renew or extend the warranty period past the period from original date of purchase.



gme.net.au

GME Pty Ltd.
17 Gibbon Road, Winston Hills NSW 2153, Australia